

**VOLUME I of I, PAGES A1-A2916**

**2015-1177**

---

**IN THE  
UNITED STATES COURT OF APPEALS  
FOR THE FEDERAL CIRCUIT**

---

IN RE: AQUA PRODUCTS, INC.

**Appeal from United States Patent and Trademark Office,  
Patent Trial and Appeal Board  
Case No. IPR2013-00159**

---

**JOINT APPENDIX**

---

JAMES R. BARNEY  
TIMOTHY P. MCANULTY  
DAVID K. MROZ  
FINNEGAN, HENDERSON, FARABOW,  
GARRETT & DUNNER, LLP  
901 New York Avenue, NW  
Washington, DC 20001-4413  
(202) 408-4000

July 24, 2015

*Attorneys for Appellant  
Aqua Products, Inc.*

---

**INDEX TO APPENDIX MATERIALS**  
**Appeal No. 15-1177**  
**USPN 8,273,183**

Final Written Decision, August 22, 2014 .....	A1-A57
Exhibit 1006, U.S. Patent No. 8,273,183.....	A58-A88
Decision on Institution of <i>Inter Partes</i> Review, August 23, 2013 .....	A89-A123
Certified List .....	A124-A128
Excerpts from Oral Hearing Transcript, mailed August 4, 2014.....	A1029-A1055
Petition for <i>Inter Partes</i> Review, February 25, 2013 .....	A2001-A2063
Joint Stipulation, March 3, 2014.....	A2272-A2274
Patent Owner’s Replacement Corrected Motion to Amend Claims, March 3, 2014.....	A2276-A2295
Excerpts from Opposition to Patent Owner’s Replacement Corrected Motion to Amend Claims, March 10, 2014 .....	A2320-A2338
Excerpts from Patent Owner’s Reply in Support of Motion to Amend Claims, April 8, 2014.....	A2362-A2374
Excerpts from Patent Owner’s Corrected Reply in Support of Motion to Amend Claims, April 15, 2014 .....	A2391-A2403
Excerpts from Patent Owner’s Submission of Demonstrative Exhibits, May 13, 2014.....	A2473-A2482
Excerpts from Petitioner’s Submission of Demonstrative Exhibits, May 13, 2014.....	A2486-A2497
Exhibit 1001, U.S. Patent No. 3,321,787 (Myers).....	A2507-A2513
Exhibit 1002, U.S. Patent No. 3,936,899 (Henkin) .....	A2514-A2525
Exhibit 1003, U.S. Patent No. 4,100,641 (Pansini) .....	A2526-A2542

Excerpts from Exhibit 1004, U.S. Patent No. 4,429,429 (Altschul).....	A2543-A2555
Excerpts from Exhibit 1010, Declaration of Homayoon Kazerooni, PhD in Support of Petitioner’s Reply to Patent Owner’s Response to Petition and Petitioner’s Oppositions to Patent Owner’s Motion to Amend Claims.....	A2574-A2575
Exhibit 2016, Corrected Declaration of Giora Erlich in Support of Patent Owner’s Replacement Corrected Motion to Amend Claims and Patent Owner’s Response to Petition for <i>Inter Partes</i> Review .....	A2772-A2806
Patent Owner Aqua Products Notice of Appeal, October 23, 2014.....	A2911-A2916

UNITED STATES PATENT AND TRADEMARK OFFICE

---

BEFORE THE PATENT TRIAL AND APPEAL BOARD

---

ZODIAC POOL SYSTEMS, INC.,  
Petitioner,

v.

AQUA PRODUCTS, INC.,  
Patent Owner.

---

Case IPR2013-00159  
Patent 8,273,183 B2

---

Before BRIAN J. McNAMARA, RAMA G. ELLURU, and  
JAMES B. ARPIN, *Administrative Patent Judges*.

ARPIN, *Administrative Patent Judge*.

FINAL WRITTEN DECISION  
*35 U.S.C. § 318(a) and 37 C.F.R. § 42.73*

I. BACKGROUND

Zodiac Pool Systems, Inc. (“Petitioner”) filed a Petition to institute an *inter partes* review (Paper 5) of claims 1–14, 16, and 19–21 of U.S. Patent No. 8,273,183 B2 (Ex. 1006; “the ’183 Patent”) pursuant to 35 U.S.C. §§ 311–312 and 37 C.F.R. §§ 42.100–42.106. Pursuant to 35 U.S.C. § 314,

IPR2013-00159  
Patent 8,273,183 B2

we instituted an *inter partes* review, on August 23, 2013, as to claims 1–9, 13, 14, 16, and 19–21 of the '183 Patent, but not with respect to claims 10–12. Paper 18.

After institution, Patent Owner filed a Response to Petition (Paper 28) and a contingent, Replacement Corrected Motion to Amend Claims (Paper 42).<sup>1</sup> Petitioner filed a Reply to Patent Owner's Response to Petition (Paper 44) and an Opposition to Patent Owner's Replacement Corrected Motion to Amend Claims (Paper 45). Patent Owner further filed a Corrected Reply in Support of Motion to Amend Claims (Paper 55) and a Corrected Sur-Reply in Support of Opposition to Petition (Paper 56).

In addition, Patent Owner filed a Motion to Exclude Evidence. Paper 58. Petitioner filed an Opposition to Patent Owner's Motion to Exclude Evidence (Paper 61), and Patent Owner filed a Reply Memorandum in Support of its Motion to Exclude Evidence (Paper 62). The Motion to Exclude Evidence seeks to exclude certain portions of the declaration of Petitioner's declarant, Mr. Keith McQueen, (Ex. 1009) and the entire declaration of Petitioner's declarant, Dr. Homayoon Kazerooni, (Ex. 1010). Paper 58, 1–5.

An oral hearing was held on May 20, 2014, a transcript of which appears in the record. Paper 70.

We have jurisdiction under 35 U.S.C. § 6(c). This final written decision is entered pursuant to 35 U.S.C. § 318(a).

---

<sup>1</sup> Patent Owner initially filed a Motion to Amend Claims (Paper 27) on Nov. 25, 2013, and a Corrected Motion to Amend Claims (Paper 39) on Feb. 18, 2014. Because we required Patent Owner to refile the Corrected Motion to Amend Claims, the motion under consideration in this case was filed on Mar. 3, 2014.

IPR2013-00159  
Patent 8,273,183 B2

For the reasons that follow, we determine that Petitioner has shown by a preponderance of the evidence that challenged claims 1-9, 13, 14, 16, and 19–21 are *unpatentable*. Further, for the reasons that follow, we *deny* the Replacement Corrected Motion to Amend Claims requesting entry of substitute claims 22–24.

Patent Owner’s Motion to Exclude Evidence is *granted-in-part* and *denied-in-part*.

#### *A. Related Proceedings*

In addition to this proceeding, the ’183 Patent is involved in concurrent district court litigation captioned *Aqua Products, Inc. v. Zodiac Pool Systems, Inc.*, 1:12-cv-09342-TPG (S.D.N.Y.). *See* Paper 5, 1.

#### *B. The ’183 Patent*

The ’183 Patent relates to self-propelled apparatus and methods for controlling such apparatus for cleaning a submerged surface of a pool or tank. Ex. 1006, col. 1, ll. 22–26. Although such apparatus are propelled by a water jet, the ’183 Patent states that the movement of such apparatus is random. *Id.* at col. 2, ll. 57–59. The ’183 Patent describes methods for controlling the scanning and traversing patterns of the cleaning apparatus with respect to the bottom and sidewalls of the pool or tank. *Id.* at col. 1, ll. 22–26. In the ’183 Patent, “[r]eferences to the front or forward end of the cleaner will be relative to its then-direction of movement.” *Id.* at col. 4, ll. 11–12.

An apparatus, as recited in the claims and suitable for control according to the recited methods, is illustrated in Figure 1 of the ’183 Patent,

IPR2013-00159  
 Patent 8,273,183 B2

reproduced below:

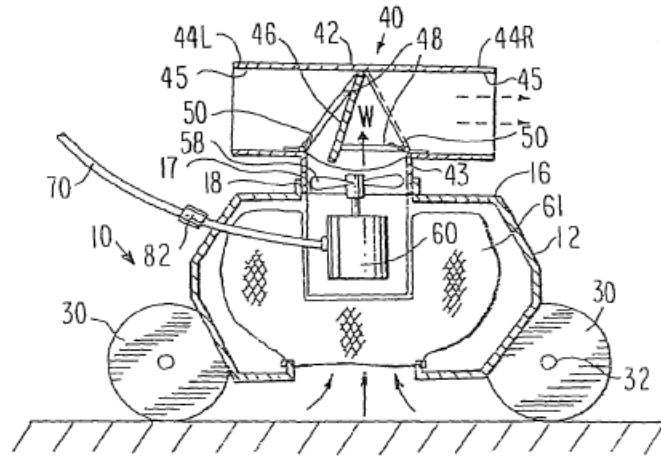


FIG. 1

Figure 1 depicts “a side elevation, partly in cross-section, of a pool cleaner illustrating one embodiment of the directional water jet of the invention.”

Ex. 1006, col. 7, ll. 1–3.

Figure 1, a schematic illustration of a cross-sectional, side view of pool or tank cleaner apparatus 10, depicts an embodiment of the directional water jet, or discharge conduit, recited in claims 1 and 20. Ex. 1006, col. 7, ll. 1–3. A water inlet (not numbered) is disposed through housing 12 and below motor-driven water pump motor 60, whereby pump motor 60 draws water and pool or tank debris through the water inlet for filtering. *Id.* at col. 8, ll. 58–61. Water drawn through the water inlet may pass through filter 61, and pool or tank debris may be entrained by filter 61. *Id.* Pool cleaner 10 further comprises valve assembly 40 forming a pump outlet that is mounted above pump motor 60. *Id.* at col. 9, ll. 4–12. Pool cleaner 10 uses impeller 58 to drive water “W” through housing aperture 17 and into valve assembly 40. *Id.* at col. 9, ll. 4–8.

As depicted in the embodiment of Figure 1 of the ’183 Patent, “valve

IPR2013-00159  
 Patent 8,273,183 B2

assembly 40 comprises a generally T-shaped valve housing 42 with depending leg 43 having a first end that is secured to cleaner housing flange 18, and a second end that is in fluid communication with discharge conduits 44R and 44L.” *Id.* at col. 9, ll. 8–12. In Figure 1, the angle formed between the surface over which pool cleaner 10 is moving and discharge conduits 44R and 44L is equal to or is substantially equal to zero, *i.e.*, discharge conduits 44R and 44L are substantially parallel to the surface of movement. Thus, discharge conduits 44R and 44L are at acute angles, *i.e.*, angles less than  $90^\circ$  (*see* claim 1) or less than normal (*see* claim 20) with respect to the surface of movement. *Id.* at col. 9, ll. 7–11. Pool cleaner 10 is propelled by the water jet created by the selective ejection of water from pump motor 60 directed by flap assembly 46 through one of discharge conduits 44R and 44L. *Id.* at col. 9, ll. 24–53; Figs. 1–3.

Alternatively, an apparatus, as recited in the claims and suitable for control according to the recited methods, is illustrated in Figure 9 of the '183 Patent, reproduced below:

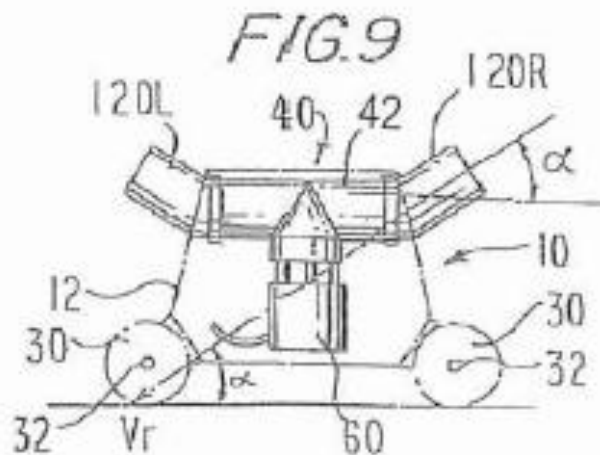


Figure 9 depicts a side elevation of embodiment illustrated in relation to a pool cleaner. Ex. 1006, col. 7, ll. 20–21.



IPR2013-00159  
Patent 8,273,183 B2

In Figure 9, a preferred embodiment of pool cleaner 10 is depicted having valve assembly 40 in which discharge conduits 44R and 44L through their associated elbows 120R and 120L project through the sidewalls of a pool cleaner housing 12 at angle  $\alpha$  that is less than  $90^\circ$  and greater than  $0^\circ$ , i.e., is acute or less than normal, with respect to the surface of movement of pool cleaner 10. *Id.* at col. 10, ll. 47–48, 60–64; *see id.* at col. 24, ll. 6–25; col. 26, ll. 1–24 (Claims 1 and 20). Thus, the direction of movement may change depending upon which conduit ejects the water. *Id.* In the alternative embodiment depicted in Figure 9, elbows 120R and 120L cause a resultant force vector component generated by the water jet to move housing 12 in a direction away from the discharged water jet and another resultant force vector component to urge housing 12 downward against the pool or tank surface over which pool cleaner 10 moves. *Id.* at col. 10, ll. 47–51; Fig. 8. Pool cleaner 10 further comprises rotationally-mounted supports, i.e., wheels 30 mounted on a pair of axles 32. *Id.* at col. 10, ll. 47–66. Each of axles 32 is disposed proximate to one of a front and an opposing rear end of pool cleaner 10, as defined by the direction of movement. *Id.* at col. 10, l. 64–col. 11, l. 3; *see also id.* at col. 5, ll. 9–12 (“[R]eferences to the front and rear of the cleaning apparatus or its housing will be with respect to the direction of its movement.”).

### *C. Claims Under Review*

#### *1. Challenged Claims.*

Of the challenged claims, claims 1, 20, and 21 are independent. Independent claims 1 and 20 recite similar limitations describing embodiments of a self-propelled cleaning apparatus for cleaning a

IPR2013-00159

Patent 8,273,183 B2

submerged surface of a pool or tank. Ex. 1006, col. 24, ll. 6–7; col. 26, ll. 1–2. Independent claim 21 recites “[a] method for cleaning a submerged surface of a pool or tank.” *Id.* at col. 26, ll. 25–26. As to the dependent claims, challenged claims 2-9, 13, 14, 16, and 19 depend from claim 1.

Independent claim 21 of the ’183 Patent is illustrative of the claims at issue:

21. A method for cleaning a submerged surface of a pool or tank, comprising the steps of:

providing a self-propelled cleaning apparatus, said cleaning apparatus including a housing having a baseplate with at least one water inlet, and further including a front portion as defined by the direction of movement of the cleaning apparatus when propelled by a water jet, an opposing rear portion and adjoining side portions defining the periphery of the apparatus, rotationally-mounted supports coupled to the housing to enable movement of said apparatus over the submerged surface, a water pump mounted in the interior of said housing, and a directional discharge conduit in fluid communication with the water pump and having at least one discharge opening;

activating the water pump to draw water and debris from the pool or tank through the at least one water inlet; filtering the water drawn into the housing;

discharging the filtered water through the directional discharge conduit at an acute angle with respect to the surface over which the apparatus is moving, said discharged filtered water forming a water jet having a resultant force vector acutely angled towards the surface beneath the apparatus; and

propelling the apparatus in a forward direction of movement.

## 2. *Proposed Substitute Claims*

In its Replacement Corrected Motion to Amend Claims, Patent Owner proposes claims 22–24, as substitute claims for original claims

IPR2013-00159

Patent 8,273,183 B2

1, 8, and 20, respectively. Paper 42, 2. The substitute claims are reproduced below, with underlined material indicating language added to the corresponding original claims and struck-through indicating language removed from the corresponding original claims:

22. (Proposed substitute for original claim 1) A self-propelled cleaning apparatus for cleaning a submerged surface of a pool or tank, comprising:

a housing having a front portion as defined by the direction of movement of the apparatus when propelled by a water jet, an opposing rear portion and adjoining side portions defining the periphery of the apparatus, and a baseplate with at least one water inlet;

rotationally-mounted supports axially mounted transverse to a longitudinal axis of said apparatus and coupled proximate the front and rear portions of the housing to enable control the directional movement of said apparatus over the submerged surface;

a water pump mounted in the interior of said housing, said water pump being configured to draw water and debris from the pool or tank through the at least one water inlet for filtering; and

a stationary directional discharge conduit in fluid communication with the water pump and having at least one discharge opening through which a pressurized stream of water forming the water jet is directionally discharged at a predetermined angle that is acute with respect the surface over which the apparatus is moving,

wherein said predetermined angle is inclined upwardly with respect to the surface beneath the apparatus to produce a resultant force vector that is directed to a position that is proximate to and rearwardly displaced from a line passing through the transverse axial mountings of the front rotationally-mounted supports.

23. (Proposed substitute for original claim 8) The apparatus of claim ~~[[7]]~~ 22, wherein the rotationally-mounted

IPR2013-00159

Patent 8,273,183 B2

supports comprise first and second pairs of axially mounted wheels respectively positioned proximate to the front and rear portions of the housing, wherein a portion of the discharge conduit terminating in the at least one discharge opening is angled upward with respect to an adjacent portion of the discharge conduit to produce a resultant force vector in the water jet discharged from said at least one discharge opening that is directed to pass through proximately to and rearwardly of the plane of the axis of rotation of the pair of wheels at the front portion of the apparatus.

24. (Proposed substitute for original claim 20) A self-propelled cleaning apparatus for cleaning a submerged surface of a pool or tank, said apparatus having a longitudinal axis and being propelled by the discharge of a water jet, the apparatus comprising:

a housing including a baseplate with at least one water inlet, a front portion, a rear portion and opposing side portions defining the periphery of the apparatus, said front portion being defined with respect to the forward directional movement of the apparatus when propelled by the water jet;

~~rotationally mounted supports~~ at least a front pair of wheels, each wheel axially mounted transverse to the longitudinal axis and coupled to the housing to ~~enable control the directional~~ movement of said apparatus over the submerged surface;

a water pump mounted in the interior of said housing, said water pump configured to draw water and debris from the pool or tank through the at least one water inlet for filtering, and a pump discharge outlet for emitting a pressurized stream of filtered water;

a stationary directional discharge conduit in fluid communication with the pump discharge outlet, the discharge conduit having at least one discharge opening through which the filtered water jet is directionally discharged from the apparatus at a predetermined angle

IPR2013-00159

Patent 8,273,183 B2

that is less than normal with respect to the surface beneath the apparatus, wherein said predetermined angle is inclined upwardly with respect to the surface beneath the apparatus to produce a resultant force vector that is directed to a position that is proximate to and rearwardly displaced from a line passing through the transverse axial mountings of the front pair of wheels.

*Id.* at 2-5.

#### *D. Grounds of Unpatentability*

Petitioner relies upon the following prior art references and declarations to support the grounds upon which we instituted an *inter partes* review:

Exhibit No.	References and Declarations
1001	U.S. Patent No. 3,321,787 to R.R. Myers (“Myers”), issued May 30, 1967
1002	U.S. Patent No. 3,936,899 to Henkin et al. (“Henkin”), issued Feb. 10, 1976
1003	U.S. Patent No. 4,100,641 to Pansini (“Pansini”), issued July 18, 1978
1009	Declaration of Mr. Keith McQueen in Support of Petitioner’s Reply to Patent Owner’s Response to Petition (Mar. 10, 2014) (“Declaration of Mr. McQueen”)
1010	Declaration of Homayoon Kazerooni, Ph.D. in support of Petitioner’s Reply to Patent Owner’s Response to Petition and Petitioner’s Opposition to Patent Owner’s Replacement Corrected Motion to Amend Claims (Mar. 10, 2014) (“Declaration of Dr. Kazerooni”)

IPR2013-00159  
 Patent 8,273,183 B2

We instituted *inter partes* review of the '183 Patent based upon the following asserted grounds of unpatentability:

Claims	Statutory Basis	Applied Reference(s)
1, 2, 13, 14, 16, and 19–21	35 U.S.C. § 102(b)	Myers
1–5 and 19–21	35 U.S.C. § 103(a)	Henkin and Myers
1–9 and 19–21	35 U.S.C. § 103(a)	Pansini and Myers

Paper 18, 34.

## II. DISCUSSION

In the Response to Petition, Patent Owner only addresses claim 21 and does not address expressly claims 1-9, 13, 14, 16, 19, and 20. Paper 28, 1–2. Nevertheless, although Patent Owner waived argument on all of the claims other than claim 21 and then filed the Replacement Corrected Motion to Amend Claims on other claims, Patent Owner does not concede that the original claims, other than claim 21, would not be patentable. Paper 70, 22:7–24; *see* Paper 42, 2, n.2. We have reviewed the evidence presented by Petitioner regarding the claims upon which we instituted *inter partes* review and determine that, for the reasons set forth below, Petitioner has shown by a preponderance of the evidence that claims 1-9, 13, 14, 16, and 19–21 are unpatentable.

IPR2013-00159  
Patent 8,273,183 B2

### *A. Claim Construction*

Consistent with the statute and legislative history of the Leahy-Smith America Invents Act, Pub. L. No. 112-29, 125 Stat. 284 (2011) (“AIA”), the Patent Trial and Appeal Board (“the Board”) interprets claims using the broadest reasonable construction in light of the specification of the patent in which they appear. 37 C.F.R. § 42.100(b); *see also* Office Patent Trial Practice Guide, 77 Fed. Reg. 48,756, 48,766 (Aug. 14, 2012). Under the broadest reasonable construction standard, claim terms are given their ordinary and customary meaning as would be understood by one of ordinary skill in the art in the context of the specification. *In re Translogic Tech., Inc.*, 504 F.3d 1249, 1257 (Fed. Cir. 2007) (quoting *Phillips v. AWH Corp.*, 415 F.3d 1303, 1312 (Fed. Cir. 2005) (en banc)). Any special definition for a claim term must be set forth in the specification with “reasonable clarity, deliberateness, and precision.” *In re Paulsen*, 30 F.3d 1475, 1480 (Fed. Cir. 1994). We are careful, however, not to read a particular embodiment appearing in the written description into the claim if the claim language is broader than the embodiment. *In re Van Geuns*, 988 F.2d 1181, 1184 (Fed. Cir. 1993). Our analysis requires the construction of the following claim terms.

#### *1. a stationary directional discharge conduit*

As noted in our Decision to institute *inter partes* review, claim 1 limits the apparatus to “*a stationary directional discharge conduit*,” and independent claims 20 and 21 recite “*a directional discharge conduit*.” Ex. 1006, col. 24, l. 20; col. 26, ll. 19, 36-37 (emphases added). Further, we note that Patent Owner includes this limitation of claim 1 in substitute claims 22–24. Paper 42, 2–5. Referring to the language of claim 1 and to

IPR2013-00159  
Patent 8,273,183 B2

the Specification, we found no definition for a stationary directional discharge conduit. Although the Specification describes various embodiments of such discharge conduits, e.g., discharge conduits 44R and 44L (Ex. 1006, col. 9, ll. 8–12), we do not limit the interpretation of this term to such embodiments. *Van Geuns*, 988 F.2d at 1184.

Considering the language of claim 1, a relevant definition of the term “stationary” is “not moving or not movable; fixed or still.” WEBSTER’S NEW WORLD DICTIONARY, 1309 (3rd College ed. 1988) (Ex. 3002). Moreover, a relevant definition of the term “directional” is “of, aimed at, or indicating (a specific) direction.” *Id.* at 389. Petitioner noted that, during prosecution, Patent Owner argued in overcoming the Examiner’s proposed Restriction Requirement that

[A] pool cleaner apparatus [that] employs *at least one* discharge opening through which the water jet is directionally discharged from the cleaning apparatus at a predetermined angle that is less than normal with respect to the surface beneath the apparatus. *At least one* angled discharge outlet 120R and/or 120L extends from the jet valve assembly 40, as described in paragraphs 0091 through 0094 and shown in Figs. 8 and 9 of the present application.

Paper 5, 6 (quoting Response to Restriction/Election Requirement (Ex. 1005) 2 (emphases added)).

Neither Patent Owner nor Petitioner contests this construction. We further note that claim 6, which depends directly from claim 1, recites that “the discharge conduit has *at least two* discharge openings, each of which discharge openings is located at opposite ends of the discharge conduit” (Ex. 1006, col. 24, ll. 44–46 (emphasis added)). Thus, “a stationary directional discharge conduit” of claim 1 broadly includes conduits with one



IPR2013-00159  
 Patent 8,273,183 B2

or more discharge openings, and we also apply this interpretation to the use of this term in the substitute claims.<sup>2</sup> Therefore, consistent with the language of claim 1, the description in the Specification, and the prosecution history of the '183 Patent, we conclude that the broadest reasonable interpretation of “a stationary directional discharge conduit” is one or more discharge conduits, each of which is stationary and is oriented in a particular direction, e.g., that does not move and is aligned relative to a given axis of the apparatus. *See KCJ Corp. v. Kinetic Concepts, Inc.*, 223 F.3d 1351, 1356 (Fed. Cir. 2000) (“an indefinite article ‘a’ or ‘an’ in patent parlance carries the meaning of ‘one or more’ in open-ended claims containing the transitional phrase ‘comprising’”) (citations omitted).

2. *a front portion as defined by the direction of movement of the apparatus when propelled by a water jet*

Independent claim 1 recites, and claim 21 similarly recites, that a housing has “a front portion *as defined by the direction of movement of the apparatus when propelled by a water jet.*” Ex. 1006, col. 24, ll. 8–10; col. 26, ll. 29–31 (emphasis added). Patent Owner includes this limitation in substitute claims 22 and 23. Independent claim 20 and substitute claim 24 similarly recite that “said front portion *being defined with respect to the forward directional movement* of the apparatus when propelled by the water jet.” Ex. 1006, col. 26 ll. 7–10; Paper 42, 2 (emphasis added).<sup>3</sup> As used in

---

<sup>2</sup> Other claims can be valuable sources in determining the meaning of a claim term. *See Vitronics Corp. v. Conceptoronic, Inc.*, 90 F.3d 1576, 1582 (Fed. Cir. 1996). Because claim terms normally are used consistently throughout the claims, the usage of a term in one claim can illuminate the meaning of the same or similar terms in other claims. *See Rexnord Corp. v. Laitram Corp.*, 274 F.3d 1336, 1342 (Fed. Cir. 2001); *CVI/Beta Ventures, Inc. v. Tura LP*, 112 F.3d 1146, 1159 (Fed. Cir. 1997).

<sup>3</sup> *See supra* n.2.

IPR2013-00159  
Patent 8,273,183 B2

each of these claims, this language describes the front portion based on (1) the direction of movement of the apparatus, and (2) the time, e.g., “when” the apparatus is propelled “by a water jet.”

As we explained in our Decision to institute *inter partes* review, with respect to the first basis for describing the “front portion,” the Specification states that the movement of the apparatus is random. Paper 18, 10–11 (citing Ex. 1006, col. 2, ll. 57–59; col. 5, ll. 4–9). The Specification further explains that the “[r]eference to the front or forward end of the cleaner will be *relative* to its *then*-direction of movement.” *Id.* at col. 4, ll. 11–12 (emphases added); *see id.* at col. 5, ll. 9–12. Thus, we concluded that the “front portion” of the housing may change with time, and no single portion of the housing may be identified exclusively as the “front portion.”

Similarly, with respect to the second basis for describing the “front portion,” i.e., “when” the apparatus is propelled by a water jet, the Specification states that “the invention comprehends a method of propelling a pool or tank cleaner by means of a water jet that is discharged [from a discharge conduit] in *at least* a first and a second direction that result in opposite translational directions.” *Id.* at col. 4, ll. 50–54 (emphasis added). Nevertheless, we do not interpret the language of claim 1 as limited to such an embodiment. The scope of this limitation is determined by the number and direction of orientation of the discharge conduits.

First, claim 1, as well as substitute claims 22–24, recites that the apparatus comprises “*a stationary directional discharge conduit.*” *Id.* at col. 24, l. 20; Paper 42, 3, 4 (emphasis added). As noted above, under the broadest reasonable interpretation, this limitation describes one or more such conduits. Second, although embodiments of the invention are depicted as

IPR2013-00159  
Patent 8,273,183 B2

having opposing discharge conduits, e.g., discharge conduits 44R and 44L, as noted above, we do not read a particular embodiment appearing in the Specification into the claim, especially if, as here, the claim language is broader than the particular embodiment. *Van Geuns*, 988 F.2d at 1184; see Ex. 1006, Figs. 1, 9 (depicting discharge conduits 44R and 44L). Third, during prosecution, Applicants argued that the claimed apparatus employ “*at least one* discharge opening through which the water jet is directionally discharged.” Paper 5, 6 (quoting Response to Restriction/Election Requirement (Ex. 1005) 2 (emphasis added)). This argument is consistent with the language of claims 1 and 6, as discussed above in Section II.A.1.

Patent Owner argues that the “front” of the recited apparatus “remains constant in terms of the direction of movement” and, in particular, “[t]he front portion of Patent Owner’s cleaner remains *in constant alignment with the water jet* which is propelling the cleaner in ‘**a forward** direction’” (emphasis added). Paper 28, 4–5 (citing the language of claim 21). Petitioner disagrees. Paper 44, 2–4.

Patent Owner does not identify support in the claim language or in the Specification for its argument regarding the “constant alignment” of the front of the apparatus with the water jet. Patent Owner relies instead on a dictionary definition of the indefinite article “a” (Ex. 2014) and on Mr. Giora Erlich’s declaration (Ex. 2016 ¶¶ 55–56). Paper 28, 5. With respect to the dictionary definition, Mr. Erlich’s interpretation of the indefinite article “a” is inconsistent with the recitation in claim 6 of an apparatus having multiple conduit openings. Further, Mr. Erlich bases his opinion on the depiction of the apparatus in Figure 1A of the ’183 Patent to demonstrate that “a single ‘front portion’ . . . remains in constant alignment with the

IPR2013-00159  
Patent 8,273,183 B2

water jet.” Ex. 2016 ¶ 56.

On this evidence, however, we are not persuaded to read the limitations of this depicted embodiment of the Specification into the claims. *Van Geuns*, 988 F.2d at 1184. Consistent with the language of the claims, the disclosure of the Specification, and the prosecution history, we interpret this limitation as providing that the location of the front portion on the apparatus varies with the movement of the apparatus, both over time and depending upon the number and direction of orientation of one or more discharge conduits through which the water jet is discharged.

*3. an opposing rear portion and adjoining side portions*

Independent claims 1 and 21 recite that the front portion, together with “an opposing rear portion and adjoining side portions” define the periphery of the apparatus. Ex. 1006, col. 24, l. 10; col. 26, ll. 31-33; Abstract. Patent Owner includes this limitation in proposed substitute claims 22 and 23. Paper 42, 2–3. Independent claim 20 and proposed substitute claim 24 similarly recite “a front portion, a rear portion and opposing side portions defining the periphery of the apparatus.” Ex. 1006, col. 26, ll. 6–7; Paper 42, 4. The Specification states that “references to the front *and rear* of the cleaning apparatus or its housing will be with respect to the direction of its movement.” Ex. 1006, col. 5, ll. 10–12 (emphasis added). Consistent with the broadest reasonable interpretation of the “front portion,” as set forth above, the “rear portion” is opposite to the “front portion” of the apparatus and, like the front portion, the location of the rear portion on the apparatus varies with the movement of the apparatus, both over time and depending upon the number and direction of orientation of one or more discharge conduits through which the water jet is discharged.

IPR2013-00159  
Patent 8,273,183 B2

Because the side portions adjoin the front and rear portions, as with the front and rear portions, we interpret the location of the side portions on the apparatus to vary with the movement of the apparatus, both over time and depending upon the number and direction of orientation of one or more discharge conduits through which the water jet is discharged. Therefore, the rear and side portions are defined relative to the varying front portion.

*4. rotationally-mounted supports coupled proximate the front and rear portions of the housing*

Independent claim 1 recites “rotationally-mounted supports coupled proximate the front and rear portions of the housing.” Ex. 1006, col. 24, ll. 13–14. Claim 21 similar recites “rotationally-mounted supports coupled to the housing.” *Id.* at col. 26, ll. 33–34. We find no express definition, in the Specification or agreed upon by the parties, for rotationally-mounted supports. Patent Owner includes this limitation in substitute claims 22 and 23. The Specification, however, describes that

[A] further object of the invention is to provide an improved apparatus and method for varying the position of one or more of *the wheels or other support means* of the cleaner in order to vary the directional movement and scanning patterns of the apparatus with respect to the bottom surface of the pool or tank being cleaned.

Ex. 1006, col. 3, ll. 35–40 (emphasis added). The Specification also describes that the cleaner may move “on *supporting wheels, rollers or tracks* that are aligned with the longitudinal axis of the cleaner body when it moves in a straight line.” *Id.* at col. 4, ll. 8–11 (emphasis added). Referring, for example, to Figure 1, wheels 30 mounted on axles 32 are depicted as disposed at either end of pool cleaner 10.

IPR2013-00159  
Patent 8,273,183 B2

A definition of the verb “to support” is “to carry or bear (a specific weight, strain, pressure, etc.),” and a definition of the noun “support” is “a person or thing that supports, esp. financially.” WEBSTER’S NEW WORLD DICTIONARY (Ex. 3002) at 1345. A definition of the noun “rotation” is “rotating or being rotated.” *Id.* at 1168. Thus, we interpret the term “rotationally-mounted supports” to recite two or more things (including, but not limited to wheels, rollers, and tracks) that carry or bear the housing of the apparatus and which are mounted to the housing, so that the supports may rotate or turn, for example, on an axis.<sup>4</sup> Nevertheless, because the front and rear of the apparatus are determined by its direction of movement at any particular point in time, whether the rotationally-mounted supports are “coupled proximate to the front and rear portions of the housing” depends upon the direction of movement of the apparatus at a given time.

5. *towards the surface beneath the apparatus*

Independent claim 21 recites “said discharged filtered water forming a water jet having a resultant force vector acutely angled *towards the surface beneath the apparatus.*” Ex. 1006, col. 26, ll. 45– 48 (emphasis added). Independent claim 20 recites a limitation similar to that of claim 21. Independent claim 1, however, recites that “a pressurized stream of water forming the water jet is directionally discharged at a predetermined angle that is acute *with respect the surface over which the apparatus is moving.*” *Id.* at col. 26, ll. 22– 25 (emphasis added). Each of these limitations

---

<sup>4</sup> Substitute claim 23 recites that “the rotationally-mounted supports *comprise* first and second pairs of axially mounted wheels respectively positioned proximate to the front and rear portions of the housing.” Paper 42, 3 (emphasis added). Differences among claims can be a useful in understanding the meaning of particular claim terms. *See Laitram Corp. v. Rexnord, Inc.*, 939 F.2d 1533, 1538 (Fed. Cir. 1991).

IPR2013-00159  
Patent 8,273,183 B2

describes the force or the direction of the water jet with respect to the “surface,” rather than with respect to the apparatus. In proposed substitute claims 22 and 24, Patent Owner further limits the recitations of original claims 1 and 20, respectively, such that the angles of the force and of the direction of the water jet are described relative to the front rotationally-mounted supports or pairs of wheels.

With respect to the recitations of claims 20 and 21, a relevant definition of the preposition “towards” is “in the direction of,” and a relevant definition of the preposition “beneath” is “below; lower than.” WEBSTER’S NEW WORLD DICTIONARY (Ex. 3002) at 129, 1414-15. Thus, we conclude that these limitations describe the surface beneath the apparatus, but are not limited to the relative dispositions of the rotationally-mounted supports. With respect to claim 1, however, the corresponding limitation refers more broadly to the surface “over which the apparatus is moving.” Consequently, with respect to claim 1, the predetermined angle may be acute with regard to any portion of that surface, regardless whether or not it lies *beneath* the apparatus. *See* Paper 42, 10–11 (quoting the deposition of Mr. Erlich regarding the criticality of the angle with respect to the apparatus and the surface). We construe the corresponding limitations of substitute claims 22–24 more narrowly than original claims 1, 8, or 20 in view of the added recitations describing the angles relative to the positions of the front, rotationally-mounted supports or pairs of wheels. *Cf., e.g.*, Ex. 1006, col. 24, ll. 28–34, 38–43 (Claims 3, 5).

#### *6. Remaining Claim Terms or Phrases*

All remaining claim terms and phrases recited in the challenged or substitute claims are given their ordinary and customary meanings,

IPR2013-00159  
Patent 8,273,183 B2

consistent with the Specification, as would be understood by one with ordinary skill in the art, and need not be construed explicitly here.

*B. Grounds for Review*

*1. Anticipation by Myers*

“A claim is anticipated only if each and every element as set forth in the claim is found, either expressly or inherently described, in a single prior art reference.” *Verdegaal Bros., Inc. v. Union Oil Co. of Cal.*, 814 F.2d 628, 631 (Fed. Cir. 1987) (citations omitted). Petitioner argues that Myers discloses, expressly or inherently, each and every element of claims 1, 2, 13, 14, 16, and 19–21. Paper 5, 8–11, 21–23, 26–27, 40–42, 45–47, 52–53.

Figures 1 and 2 of Myers are reproduced below, including Petitioner’s annotations. *See* Paper 5, 8 (depicting annotated versions of Myers’s Figs. 1 and 2).



IPR2013-00159  
Patent 8,273,183 B2

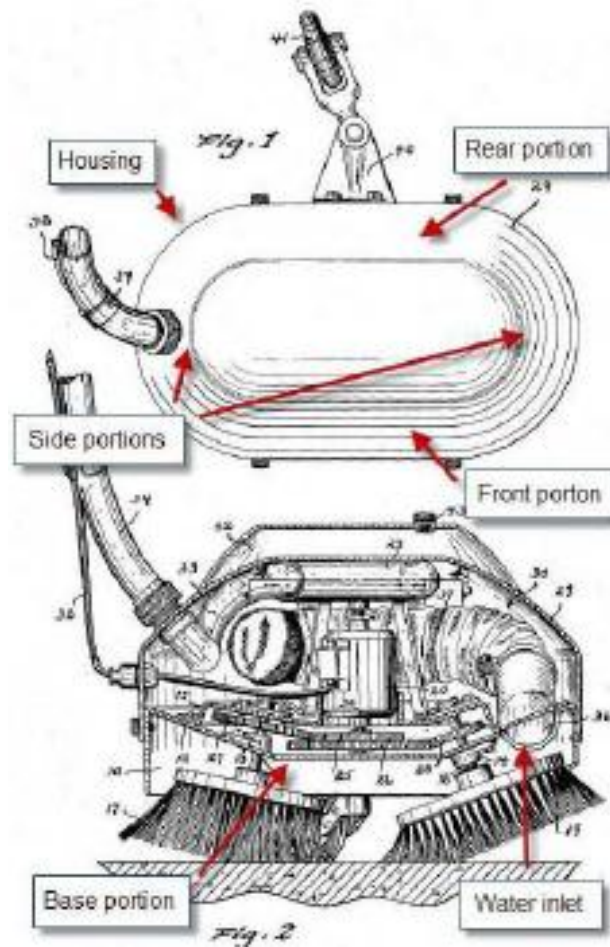


Figure 1 depicts a top plan view of a swimming pool cleaning means according to Myers's invention, and Figure 2 depicts a cross-sectional view of the swimming pool cleaning means, as depicted in Myers's Figure 1.

Ex.1001, col. 1, ll. 42–43.

Petitioner annotated these figures to identify elements of Myers's device corresponding to the housing, including front, rear, and side portions; the base portion, e.g., the baseplate; and the water inlet. In view of our claim interpretation, the identifications of the front, rear, and side portions in Petitioner's annotated Figure 2 are merely illustrative of those portions at a point in time.

Referring to Figures 1 and 2, Petitioner argues that Myers depicts “a

IPR2013-00159  
Patent 8,273,183 B2

self-propelled cleaning apparatus for cleaning a submerged surface of a pool or tank.” Paper 5, 8; *see* Ex. 1006, Claim 21 (preamble). In particular, Myers indicates that the disclosed “invention relates to a swimming pool cleaning device and more particularly to a cleaning means that is erratically self-propelled over the bottom surface of the swimming pool.” Paper 5, 8 (quoting Ex. 1001, col. 1, ll. 8–11). Moreover, Petitioner argues that Myers’s device includes the claimed “housing,” i.e., hood 29, having front, opposing rear, and adjoining side portions, which define the periphery of the device. Paper 5, 8. Further, Petitioner argues that Myers’s device includes a baseplate, i.e., outer area 12, through which a water inlet, i.e., passageway 36, communicates with the outside of the device. *Id.*; *see* Ex. 1001, col. 1, 50–52; col. 2, ll. 22–24.

Referring to Figure 2, Myers depicts “a surface engaging element such as a brush or like 17” which is “rotatably mounted” on shafts at either end of hood 29. Ex. 1001, col. 1, ll. 55-61. Petitioner argues that surface engaging elements 17 correspond to the rotationally-mounted supports, as recited in claim 1. Paper 5, 8.

Finally, referring to Figure 2, Myers discloses that flexible conduit 33 may be connected to outlet opening 32 of rotary pump 13 and may pass through and terminate just beyond hood 29. Ex. 1001, col. 2, ll. 8–13. An elongated, flexible conduit, e.g., hose 34, may be attached *detachably* to the outlet portion of conduit 33 and may extend to a point outside the swimming pool. *Id.* at col. 2, ll. 13–18. Myers further explains that:

[I]f the electric motor is operated as a motor, and the conduit 33 is detached [from conduit 34], *the water exiting from the unit and into the pool will provide a jet force to move the unit.* Also due to the gear wheel sizes and other placed elements more weight will be borne on by one brush than the other brush. This

IPR2013-00159  
Patent 8,273,183 B2

is particularly true if the conduit 33 is attached.

*Id.* at col. 3, ll. 6–12 (emphasis added). Thus, Petitioner argues that Myers discloses the directional discharge conduit, as recited in claim 21, as well as the stationary directional discharge conduit, as recited in claim 1. Paper 5, 10–11.

Patent Owner disagrees (1) with our claim construction regarding the recitation in claim 21 of “a front portion as defined by the direction of movement of the cleaning apparatus when propelled by a water jet” (*see supra* Section II.A.2) and (2) with Petitioner’s reading of Myers’s disclosure on the language of claim 21. Paper 28, 3–7. First, Patent Owner contends that “even if the ‘front’ changes on reversal of movement, the ‘front’ nonetheless remains constant in terms of the direction of movement.” *Id.* at 4. Thus, Patent Owner contends that we erred in concluding that “the front portion of the housing may change with time, and no single portion of the housing may be identified exclusively as the front portion.” Paper 18, 11. Consequently, Patent Owner contends that “[t]he front portion of Patent Owner’s cleaner remains in constant alignment with the water jet which is propelling the cleaner in ‘a forward direction.’” Paper 28, 5. As we noted above, the challenged claims simply do not include any recitation regarding a “constant alignment” between the front portion of the apparatus and the water jet.

Patent Owner further argues that

the water jet of the Myers’ cleaner provides an ancillary force vector that contributes to the intended erratic, and not necessarily forward, movement of the cleaner. [Ex. 2016 ¶¶ 57, 60.] This ancillary force vector works in conjunction with the single projecting swivel wheel and the pair of brushes that are

IPR2013-00159  
Patent 8,273,183 B2

axially mounted at an acute angle displaced slightly from the vertical to create erratic movement. *Id.* at 60[.]

Paper 28, 5. Nevertheless, as we have discussed, the front of the apparatus is determined by the direction of movement. Even accepting that Myers's apparatus may engage in erratic movement, such movement still may define a front portion at any given time. Further, erratic movement is not necessarily inconsistent with "propelling the apparatus *in a forward direction* of movement," as recited in claim 21. Ex. 1006, col. 26, ll. 49–50 (emphasis added); *compare* Paper 70, 23:23–24:2 ("[T]he fact is that once that front starts, once there is a correlation, once there is a movement, there is a front, the direction of motion are related. Therefore, structurally there has to be sometimes both a front and a direction -- forward direction of movement"), *with id.* at 9:3–9:6 ("There's nothing to – there's nothing in this claim that would exclude not only forward directions of movement but sideways directions of movement, components of movement that are caused by not only the jet drive but also the configuration of the apparatus.")). Patent Owner's apparatus is not limited solely to movement in a forward direction. Ex. 1006, col. 5, ll. 4–9 ("The invention comprehends methods and apparatus for controlling the movement of robotic tank and swimming pool cleaners that can be characterized as systematic scanning patterns, scalloped or curvilinear patterns *and controlled random motions with respect to the bottom surface of the pool or tank.*" (emphasis added)); *see also* Paper 70, 6:14–24 (discussing curvilinear movement depicted in Ex. 1006, Fig. 35). We agree with Patent Owner that Myers describes that its device moves "erratically" across the bottom surface of the pool. *See* Ex. 1001, col. 1, ll. 8–11, 22–24; col. 2, l. 34–col. 3, l. 5. We determine, however, that Myers's

IPR2013-00159  
Patent 8,273,183 B2

device has an identifiable, if varying, “front portion” consistent with our interpretation of the limitation recited in claim 21.

In addition, although the movement of Myers’s device may be influenced by the rotation of surface engaging elements 17 (Ex. 1001, col. 2, l. 55–col. 3, l. 5), such additional influences are not precluded by the language of claim 21. Further, we note that the “propelling limitation” of claim 21 does not limit the form of propulsion and, in particular, does not recite that the apparatus is propelled in a forward direction only by the water jet. Thus, like Myers, the movement of the recited apparatus also may be the result of the contributions of separate elements. Paper 44, 2–4; *see* Paper 70, 49:4–20. Therefore, we are not persuaded by Patent Owner’s arguments that Myers fails to disclose any of the recited elements of claim 21.

Patent Owner contends that the reasons discussed above for distinguishing the claimed invention over Myers over claim 21, apply to remaining challenged claims, claims 1, 2, 13, 14, 16, 19, and 20, as well. Paper 70, 22:7–17. We conclude that Petitioner has demonstrated by a preponderance of the evidence that claims 1, 2, 13, 14, 16, and 19–21 of the ’183 Patent are anticipated by Myers.

## 2. *Henkin and Myers*

A patent claim is unpatentable under 35 U.S.C. § 103(a) if the differences between the claimed subject matter and the prior art are “such that the subject matter, as a whole, would have been obvious at the time the invention was made to a person having ordinary skill in the art to which said subject matter pertains.” *KSR Int’l Co. v. Teleflex Inc.*, 550 U.S. 398, 406 (2007). The question of obviousness is resolved on the basis of underlying factual determinations, including: (1) the scope and content of the prior art;

IPR2013-00159  
Patent 8,273,183 B2

(2) any differences between the claimed subject matter and the prior art; (3) the level of skill in the art; and (4) objective evidence of nonobviousness, i.e., secondary considerations. *Graham v. John Deere Co.*, 383 U.S. 1, 17–18 (1966).

Petitioner argues that Henkin discloses substantially all of the limitations of challenged claims 1-5 and 19–21, except that Henkin discloses the use of an external pump, rather than an internal pump. *See* Paper 5, 13 (Claim 1), 48 (Claim 20), 54 (Claim 21). Like Myers, Henkin discloses an apparatus for cleaning submerged surfaces of a pool. Ex. 1002, col. 1, ll. 46–59. Myers, however, teaches the use of an internal pump, e.g., ordinary rotary pump 23. *See* Paper 5, 13 (Claim 1), 48 (Claim 20), 54 (Claim 21). Petitioner argues that a person of ordinary skill in the relevant art would have had a reason to modify the teachings of Henkin to replace the external pump with an internally-mounted pump to eliminate (1) the need for an external source of pressurized water and supply hose and (2) the need to manage the supply hose to prevent entanglement. *Id.* We agree.

Patent Owner argues that the method recited in claim 21 is distinguishable over Henkin and Myers for at least two reasons. Paper 28, 7–10. First, Patent Owner notes that claim 21 recites “said discharged filtered water forming a water jet having *a resultant force vector acutely angled towards the surface beneath the apparatus.*” *Id.* at 7 (citing Ex. 1006, col. 26, ll. 45– 48 (emphasis added)). Patent Owner contends, however, that Henkin fails to teach or suggest this limitation. *Id.*; *see also* Paper 5, 27 (depicting a resultant force vector aligned with Henkin’s nozzle 90 angled acutely towards the surface over which Henkin’s apparatus moves). Second, Patent Owner contends that neither Henkin nor Myers

IPR2013-00159  
Patent 8,273,183 B2

provides a person of ordinary skill in the art with a reason to combine the teachings of these references to achieve the invention recited in the challenged claims. Paper 28, 9.

Patent Owner correctly notes that Henkin's Figure 2 depicts nozzle 90 oriented at an acute angle to the surface over which Henkin's apparatus moves. *Id.* at 8. Further, as depicted in Henkin's Figure 2, water ejected from nozzle 90 would produce a resultant force directed ahead of, rather than beneath, Henkin's apparatus. *Id.* at 8. Nevertheless, Henkin teaches that nozzle 90 is adjustable. Paper 44, 6 (quoting Ex. 1002, col. 5, ll. 15–16 (describing set means for holding nozzle 90 at a selected angle)). Moreover, Henkin teaches that “[t]he angle or the nozzle 90 is selected to yield both a downward thrust component (i.e. normal to the vessel surface) for providing traction and a forward component which aids in propelling the car and facilitates the car climbing vertical surfaces and working itself out of corners.” Ex. 1002, col. 5, ll. 19–23; *see* Paper 5, 55 (claim chart for Claim 21). Thus, Henkin teaches that the angle of nozzle 90 may be adjusted and that, if an appropriate angle was selected, such an adjustment could result in a resultant force vector directed *beneath* Henkin's apparatus. Paper 70, 15:17–19; 36:6–37:19. Further, Myers depicts that a resultant force vector produced by a water jet directed *beneath* Myer's apparatus. Paper 5, 55; Paper 70, 15:11–16.

Patent Owner also contends that “neither Henkin nor Myers, provide[s] a person of ordinary skill in the art with any purpose or reason to direct the ‘discharge filtered water forming a water jet having a resultant force vector acutely angled towards the surface beneath the apparatus,’ as required by challenged claim 21.” Paper 28, 9 (citation omitted). As

IPR2013-00159  
Patent 8,273,183 B2

discussed above, Myers depicts that a resultant force vector produced by a water jet may be directed beneath Myer's apparatus. Paper 42, 8; Paper 5, 55. Petitioner argues that:

[b]oth Myers and Henkin teach propelling a cleaner using a water jet force. Accordingly, one of ordinary skill in the art would be motivated to combine the direction of the resultant force vector of Myers which provides stability with the Henkin cleaner to further increase the downward thrust component for providing traction in the Henkin cleaner in order to further increase the stability of the Henkin cleaner.

Paper 44, 8 (citations omitted). Further, as noted above, Henkin describes using the downward resultant force for a substantially similar purpose to the '183 Patent. Paper 70, 15:20–16:2; *compare* Ex. 1006, col. 10, ll. 60–64, *with* Ex. 1002, col. 5, ll. 19–23. As the U.S. Supreme Court has explained,

When there is a design need or market pressure to solve a problem and there are a finite number of identified, predictable solutions, a person of ordinary skill has good reason to pursue the known options within his or her technical grasp. If this leads to the anticipated success, it is likely the product not of innovation but of ordinary skill and common sense. In that instance the fact that a combination was obvious to try might show that it was obvious under § 103.

*KSR*, 550 U.S. at 421. We agree with Petitioner that Henkin provides a reason for combining its teachings with those of Myers and that the combination of the teachings of Henkin and Myers was “neither unpredictable nor beyond the person of ordinary skill.” *See* Paper 70, 16:22–24.

3. *Pansini and Myers*

Petitioner argues that Pansini discloses substantially all of the limitations of challenged claims 1–9 and 19–21, except that Pansini



IPR2013-00159  
Patent 8,273,183 B2

discloses the use of an external pump, rather than an internal pump. *See* Paper 5, 16 (Claim 1), 49 (Claim 20), 55–56 (Claim 21). Like Myers, Pansini discloses an apparatus for cleaning submerged surfaces of a pool. Pansini, Abstract. Myers, however, teaches the use of an internal pump, e.g., ordinary rotary pump 23. Paper 5, 16. Petitioner argues that a person of ordinary skill in the relevant art would have had a reason to modify the teachings of Pansini to replace the external pump with an internally-mounted pump to eliminate (1) the need for an external source of pressurized water and supply hose, and (2) the need to manage the supply hose to prevent entanglement. *Id.* We agree.

Patent Owner contends that (1) Pansini does not teach that the angle of its jet nozzles 20 and 22, as depicted in Pansini’s Figure 3, creates a resultant force vector directed *beneath* the cleaning apparatus (Paper 28, 10); (2) Pansini does not teach that the water pump is mounted in the interior of the housing (*id.* at 12); and (3) the combination of Pansini and Myers fails to teach these missing limitations of Pansini (*id.* at 14). For the reasons set forth below, we are not persuaded by Patent Owner’s contentions.

First, Patent Owner contends that Pansini does not disclose that the angle of its jet nozzles 20 and 22, as depicted in Pansini’s Figure 3, creates a resultant force vector directed beneath the cleaning apparatus. *Id.* at 10. Although Patent Owner is correct, Petitioner relies on Myers, rather than Pansini, to teach this particular limitation of claim 21. Petitioner argues that, although “Pansini by itself does not disclose a resultant force vector directed beneath the apparatus, Myers does disclose such a force vector, and Patent Owner does not dispute this fact.” Paper 44, 9. As Patent Owner acknowledges, Myers teaches a resultant force vector having a horizontal

IPR2013-00159  
Patent 8,273,183 B2

component and a vertical component and that “Myers only generally discloses that ‘the outlet of said pump [is] capable of serving to jet a stream of water for propelling said chassis over the floor of a swimming pool.’” Paper 28, 11 (quoting Ex. 1001, col. 7, ll. 46–48). The horizontal component may assist in propelling the apparatus, and the vertical component may assist in maintaining the apparatus in contact with the surface beneath it. *Id.* Patent Owner contends, however, that “[t]hese were not attributes even considered by Pansini or Myers.” *Id.* (citing Ex. 2016 ¶ 72). Therefore, Patent Owner contends that a person of ordinary skill in the art would not have combined the teachings of Pansini and Myers to achieve this limitation. *Id.* at 14.

Petitioner disagrees and argues that

[O]ne of ordinary skill in the art would be motivated to combine the direction of the resultant force vector of Myers (directed at the surface beneath the cleaner) which provides stability with the Pansini cleaner to further increase the hold-down force of the Pansini cleaner to further increase the stability of the Pansini cleaner.

Paper 44, 9; *see* Ex. 1010 ¶ 22 (citing Ex. 1003, col. 3, l. 66–col. 4, l. 2); Paper 70, 17:1–8, 52:23–53:9. As we noted above, the U.S. Supreme Court has explained, that “[w]hen there is a design need or market pressure to solve a problem and there are a finite number of identified, predictable solutions, a person of ordinary skill has good reason to pursue the known options within his or her technical grasp.” *KSR*, 550 U.S. at 421. Therefore, we are persuaded that Petitioner demonstrates that the combined teachings of Pansini and Myers teach a resultant vector force that may be angled beneath the apparatus, and that a person of ordinary skill in the art would

IPR2013-00159  
Patent 8,273,183 B2

have reason to combine their teachings to achieve this limitation.

Second, Patent Owner argues that Pansini does not teach that the water pump is mounted in the interior of the housing, and that a person of ordinary skill in the relevant art would be discouraged from combining the teachings of Pansini and Myers to achieve that configuration. Paper 28, 12. In particular, Patent Owner argues that “Pansini was principally concerned with the fact that a cleaning apparatus fed by the pool’s circulation system would be highly susceptible to being tipped over by the drag force of the hose which provided the water source to propel the cleaning device.” *Id.* In support of this argument, Patent Owner cites a claim that was cancelled during Pansini’s prosecution, reciting that “said hose applying a drag force to said carrier tending to tip it over in a direction opposite to its direction of movement under the influence of the drive jet from said nozzle.” Ex. 2013, 25 (quoting cancelled claim 19). From this portion of the prosecution history, Patent Owner argues that “Pansini’s invention related to solving the problem of using an external pump, not eliminating it.” Paper 28, 12 (citing Ex. 2016 ¶ 70). We are not persuaded by Patent Owner’s arguments.

As noted in our Decision to institute *inter partes* review, we were not persuaded that Pansini’s teachings would discourage persons of ordinary skill in the relevant art from incorporating a pump within the housing of the cleaner described in Pansini. Paper 18, 24–25. The evidence presented in Patent Owner’s response to the petition does not now persuade us otherwise. *See* Paper 28, 12–14. Although Pansini may have been concerned that “a cleaning apparatus *fed by the pool’s circulation system* would be highly susceptible to being tipped over by the drag force of the hose which provided the water source to propel the cleaning device” (*id.* at 12 (emphasis

IPR2013-00159  
Patent 8,273,183 B2

added)), Patent Owner fails to demonstrate that Pansini's teachings are limited to such cleaner configurations. Further, although Pansini's cancelled application claim 19 recited that "said hose applying a drag force to said carrier tending to tip it over in a direction opposite to its direction of movement under the influence of the drive jet from said nozzle" (Ex. 2013, 25 (quoting cancelled claim 19)), Patent Owner does not demonstrate that Pansini's teachings are so limited. *See id.* at 13; *see also* Paper 44, 8–9 (describing Pansini's claim 1).

Finally, Patent Owner notes the purported dangers of using electrically powered pool cleaners as a reason against combining the teachings of Pansini and Myers as proposed by Petitioner. Paper 28, 14 (citing Ex. 2016 ¶¶ 19 ("In 1999, these companies (including Polaris, now owned by Zodiac) criticized and described electrically powered robotic pool cleaners as being dangerous because of the use of electrically powered components in water."), 69, 72 (describing problems with cable entanglement)). As we noted in our Decision to institute *inter partes* review, the apparatus recited in the independent claims is not limited to use in swimming pools, but also is suitable for use in tanks. Paper 18, 24; *see* Ex. 1006, col. 26, ll. 25-26 (Claim 21) ("for cleaning a submerged surface of a pool *or tank*" (emphasis added)).

In addition, although the Specification of the '183 Patent may describe embodiments of the internal pump including electric motors, claim 21 merely recites a "water pump" and does not require that the recited pump be driven by an electric motor. *See* Paper 18, 25. Similarly, we addressed the issue of power supply cable entanglement in our Decision to institute and suggested that, for example, the use of a battery might resolve this issue. *Id.*

IPR2013-00159  
Patent 8,273,183 B2

at 26. Although Patent Owner's declarant states that the use of a battery may have been undesirable and may have caused other difficulties, the declarant does not state that this option was unavailable. *See* Ex. 2016 ¶ 20. Therefore, we are not persuaded that Pansini teaches away from the Petitioner's proposed combination of Pansini and Myers, nor do we find that Pansini's teachings are limited the use of external or internal pumps.

#### 4. *Secondary Considerations*

Factual inquiries for an obviousness determination include secondary considerations based on evaluation and crediting of objective evidence of nonobviousness. *Graham*, 383 U.S. at 17. Notwithstanding what the teachings of the prior art would have suggested to one with ordinary skill in the art at the time of the '183 Patent's invention, the totality of the evidence submitted, including objective evidence of nonobviousness, may lead to a conclusion that the challenged claims would not have been obvious to one with ordinary skill in the art. *In re Piasecki*, 745 F.2d 1468, 1471–72 (Fed. Cir. 1984). Secondary considerations may include any of the following: long-felt but unsolved needs, failure of others, unexpected results, commercial success, copying, licensing, and praise. *See Graham*, 383 U.S. at 17; *Leapfrog Enters., Inc. v. Fisher–Price, Inc.*, 485 F.3d 1157, 1162 (Fed. Cir. 2007).

To be of relevance, evidence of nonobviousness must be commensurate in scope with the claimed invention. *In re Kao*, 639 F.3d 1057, 1068 (Fed. Cir. 2011) (citing *In re Tiffin*, 448 F.2d 791, 792 (CCPA 1971)); *In re Hiniker Co.*, 150 F.3d 1362, 1369 (Fed. Cir. 1998). In that regard, in order to be accorded substantial weight, there must be a nexus between the merits of the claimed invention and the evidence of secondary

IPR2013-00159  
Patent 8,273,183 B2

considerations. *In re GPAC Inc.*, 57 F.3d 1573, 1580 (Fed. Cir. 1995). “Nexus” is a legally and factually sufficient connection between the objective evidence and the claimed invention, such that the objective evidence should be considered in determining nonobviousness. *Demaco Corp. v. F. Von Langsdorff Licensing Ltd.*, 851 F.2d 1387, 1392 (Fed. Cir. 1988). The burden of showing that there is a nexus lies with the patent owner. *Id.*; see *Paulsen*, 30 F.3d at 1482.

*a. Long-Felt Need*

Here, Patent Owner argues that, prior to 1999, there was a long-felt need to provide efficient, automated cleaning devices, as recited in the challenged claims. Paper 28, 15-19. In particular, Patent Owner contends that three approaches were developed separately at the time of the invention and that the third approach was embodied in the claims of the ’183 Patent, namely, “a truly robotic cleaner driven by electrical power *that requires controlled movements.*” *Id.* at 15-16 (citing Ex. 2016 ¶ 22) (emphasis added). Consequently, Patent Owner argues that, because of the long-felt need for its products embodying the claimed invention, the subject matter of the challenged claims would not have been obvious over the combination of Henkin and Myers or Pansini and Myers. *Id.* at 17. As support, Patent Owner proffers the declaration of Mr. Erlich (Ex. 2016), who is an inventor of the ’183 Patent. *Id.* at 3, 15–19.

Patent Owner argues that “[c]ontrolling the movement of the cleaner was critical to avoiding the twisting of the electric cable which would seriously impede the cleaner’s operation.” *Id.* at 17 (citing Ex. 2016 ¶ 28). Petitioner responds that “Patent Owner’s argument is flawed because the purported ‘solution’ to the alleged ‘long felt need’ is not claimed, as Claim

IPR2013-00159  
Patent 8,273,183 B2

21 does not require or even describe controlled movement or surface stability.” Paper 44, 9. Similarly, Patent Owner fails to demonstrate that the recitations of the challenged claims solve the other problems which Patent Owner contends are the subject of long-felt need, namely, susceptibility of parts to wear and breakdown and elimination of power supply cables. Paper 28, 16–19; *see* Paper 44, 10–11. Consequently, to the extent that Patent Owner may have shown that these problems represent a long-felt need, Patent Owner fails to show a nexus between that need and limitations recited in the challenged claims of the ’183 Patent. Paper 28, 13–14. Thus, we determine that Patent Owner’s objective evidence does not support a conclusion of nonobviousness, because the evidence before us does not demonstrate adequately that the challenged claims represent a solution to the alleged long-felt need.<sup>5</sup>

*b. Failure of Others and Commercial Success*

Patent Owner further argues that its products were commercially successful and that others had failed to develop corresponding products. Paper 28, 19–20. To substantiate its argument that Patent Owner’s products were commercially successful, Patent Owner states that

Customers responded [to the introduction of its products] by purchasing more than 100,000 units in the first ten years since introduction. Sales have increased every year since 2002.

---

<sup>5</sup> Patent Owner further argues that our Decision to institute *inter partes* review “implicitly recognized that the prior art did not anticipate or render obvious this angular/vector force in deciding that claims 10–12 of the ’183 Patent are not subject to these proceedings.” Paper 28, 19. However, our Decision merely found that, by its arguments and supporting evidence, Petitioner had failed to establish a reasonable likelihood of prevailing in demonstrating the unpatentability of those claims over Exhibits 1001 and 1004. Paper 18, 31–33.

IPR2013-00159

Patent 8,273,183 B2

Within about four years from introduction annual sales of Pool Rover exceeded ten thousand units. Today, sales of jet drive products account for more than 2/3 of all Aqua Products' sales of pool cleaners.

*Id.* at 20 n.4 (citing Ex. 2016 ¶ 40). The cited portion of Mr. Erlich's declaration (Ex. 2016), however, identifies no evidence in support of these statements. Further, Patent Owner contends that Petitioner developed a product based on Patent Owner's product and that Petitioner's product also embodies the challenged claims. *Id.* at 20–21. Moreover, Patent Owner contends that, when Patent Owner's and Petitioner's products, which both allegedly embody the challenged claims, are considered together, the combined sales "represent by far the majority of sales in the United States of robotic pool cleaners." *Id.* at 22. Patent Owner, however, points to no other evidence supporting these contentions.

In addition, as Petitioner correctly points out, "information solely on numbers of units sold is insufficient to establish commercial success." Paper 44, 11 (citing *In re Baxter Travenol Labs*, 952 F.2d 388, 392 (Fed. Cir. 1991) ("Information solely on numbers of units sold is insufficient to establish commercial success.")). Petitioner also correctly notes that "Patent Owner makes no showing that these alleged sales figures are significant in the pool cleaner industry." *Id.* at 11–12 (citing *In re Huang*, 100 F.3d 135, 140 (Fed. Cir. 1996) ("Declining to find evidence of commercial success because '[a]though [the inventor's] affidavit certainly indicates that many units have been sold, it provides no indication of whether this represents a substantial quantity in this market.")). Accordingly, we find unpersuasive Patent Owner's proffered evidence of commercial success. *See Cable Elec. Prods., Inc. v. Genmark, Inc.*, 770 F.2d 1015, 1026–27 (Fed. Cir. 1985)



IPR2013-00159  
Patent 8,273,183 B2

(finding that sales of five (5) million units represent a minimal showing of commercial success because “[w]ithout further economic evidence . . . it would be improper to infer that the reported sales represent a substantial share of any definable market”).

Patent Owner also argues that “failure of others” was evidence of secondary considerations, which may lead to a conclusion that the challenged claims would not have been obvious to one with ordinary skill in the art. Paper 28, 19. Patent Owner presents insufficient evidence for us to determine whether others had attempted and failed in developing the subject matter of the challenged claims. Other than perhaps Petitioner’s failure to develop the subject matter of the challenged claims before Patent Owner,<sup>6</sup> as Petitioner notes, “no failure of any other company’s pool cleaners is discussed in the section.” Paper 44, 15. Further, “Patent Owner does not describe any other company’s attempt to produce a cleaner that would infringe Claim 21, nor does Patent Owner describe how any other company failed in their ‘attempts.’” *Id.*

In its Sur-Reply in support of its response, Patent Owner alters it asserted secondary considerations from the failure of others to copying. Paper 56, 1. Nevertheless, Petitioner previously asserted that it began development of its own product over a year before meeting with Patent Owner to discuss working together. Paper 44, 14 (citing Ex. 2016 ¶¶ 23, 24). In its Sur-Reply, Patent Owner only asserts that “[t]he adoption of Jet

---

<sup>6</sup> Patent Owner asserts that, prior to being informed of Patent Owner’s products specifications, “[Petitioner’s] representatives acknowledged that they had not previously contemplated a commercial product incorporating controlled movement jet drive.” Paper 28, 20.

IPR2013-00159  
Patent 8,273,183 B2

Drive by Zodiac *is consistent with* copying after Zodiac saw Aqua Products' Jet Drive, assessed consumer preferences and confirmed the pump flow design." Paper 56, 4 (emphasis added). We do not determine infringement in *inter partes* review, and the evidence presented by Patent Owner is insufficient to show that Petitioner copied Patent Owner's products.

After weighing the evidence of obviousness and nonobviousness of record, on balance, we conclude that the strong evidence of obviousness outweighs the weak evidence of nonobviousness.

Therefore, in view of the foregoing discussion of claim 21 and accepting Patent Owner's definition of a person of ordinary skill in the relevant art (Ex. 2016 ¶ 17), we are persuaded that Petitioner has demonstrated by a preponderance of the evidence that claims 1–5 and 19–21 of the '183 Patent are unpatentable over Henkin and Myers and that claims 1–9 and 19–21 of the '183 Patent are unpatentable over Pansini and Myers.

### *C. Motion to Amend Claims*

As noted above, Patent Owner filed a contingent, Replacement Corrected Motion to Amend Claims under 37 C.F.R. § 42.121. Paper 42. Petitioner filed an Opposition to Patent Owner's Replacement Corrected Motion to Amend Claims (Paper 45), and Patent Owner filed a Corrected Reply in Support of Motion to Amend Claims (Paper 55). Because we conclude that Petitioner has shown the challenged claims to be unpatentable, we now consider the Replacement Corrected Motion to Amend Claims.

#### *1. Scope of Motion to Amend Claims*

Pursuant to 37 C.F.R. § 42.121(a)(2), a motion to amend claims may be denied if: (1) the amendments "seek[] to enlarge the scope of the claims

IPR2013-00159  
Patent 8,273,183 B2

of the patent”; (2) the amendments “introduce new subject matter”; or (3) the amendments do not “respond to a ground of unpatentability,” upon which trial was instituted. As discussed below, we determine that substitute claims 22 and 24 presented in Patent Owner’s Replacement Corrected Motion to Amend Claims are definite and narrow the scope of the original claims, and do not introduce new subject matter. Although Patent Owner’s Replacement Corrected Motion to Amend Claims attempts to respond to grounds of unpatentability, upon which trial was instituted, for the reasons set forth below, we deny Patent Owner’s Replacement Corrected Motion to Amend Claims.

*a. Narrowing Amendments*

In substitute claim 22, Patent Owner proposes to replace the phrase “to *enable* movement of said apparatus” in claim 1 with the phrase “to *control* the directional movement of the apparatus.” Paper 42, 1 (emphasis added). Petitioner argues that replacing “enable” with “control” impermissibly broadens claim 22. Paper 45, 4. In particular, Petitioner argues that “[e]nable’ has a well-known ordinary and customary meaning of ‘to provide with the means or opportunity’ and ‘to make possible, practical, or easy.’ In contrast, ‘control’ has a well-known ordinary and customary meaning of ‘to exercise restraining or directing influence over.’” *Id.* at 4–5 (citations omitted). Thus, Petitioner contends that enable and control have different meanings and that the meaning of “control” is not contained within the meaning of “enable.” *Id.* at 5. Patent Owner responds that “[e]nable’ subsumes both controlled or uncontrolled enabled movement. ‘Control’ restricts that which is ‘enabled.’” Paper 55, 2.

IPR2013-00159  
Patent 8,273,183 B2

We are not persuaded that the term “enable” *subsumes* the term “control.” Although, as both parties acknowledge, to “enable” may mean “to make possible, practical or easy,” (*see* Paper 55, 2 (citing Paper 45, 4)), this definition does not imply the power to control. Nevertheless, we are persuaded that, in order to “control” movement, movement first must be “enabled” or that the term “control” *subsumes* the term “enable.” Thus, within the context of this substitute claim and as suggested by Petitioner, we construe the phrase “to control the directional movement” as “to *enable and control* the directional movement.” *See* Paper 55, 4. As such, we conclude that this proposed amendment to substitute is narrowing.

In substitute claims 23 and 24, Patent Owner further proposes to amend each claims 8 and 20, respectively, to recite that “said predetermined angle is inclined upwardly with respect to the surface beneath the apparatus to produce a resultant force vector that is directed to a position that is proximate to and rearwardly displaced from a line passing through the transverse axial mountings of the front rotationally-mounted supports [or of the front pair of wheels].” Paper 42, 3, 4–5. We find this limitation narrows each of these substitute claims by requiring a narrower range of acute angles for the discharge conduit, such that the resultant force vector not only is directed to the surface beneath the apparatus, but to a specific area with respect to the recited transverse axial mountings.

Petitioner contends that, because substitute claim 23 recites that “a resultant force vector ‘is directed to pass proximately to and rearwardly of the plane of the axis of rotation of the pair of wheels at the front portion of the apparatus,’ rather than ‘through’ the plane, as recited in original claim 8,” the substitute claim fails to narrow the original claim that it would

IPR2013-00159  
Patent 8,273,183 B2

replace. Paper 45, 6. In particular, Petitioner contends that, in order to narrow the original claim, the substitute claim must recite that the resultant force vector “is directed to pass *through and* proximately to and rearwardly of the plane of the axis of rotation of the pair of wheels at the front portion of the apparatus.” *Id.* (emphasis added). Patent Owner argues that Petitioner’s contention ignores the dependency of substitute claim 23, from substitute claim 22. Paper 55, 4. We agree with Patent Owner’s argument. Because we determine that substitute claim 22 properly narrows the subject matter of original claim 1, we are persuaded that substitute claim 23 also properly narrows the subject matter of original claim 8.

Patent Owner contends that the remaining limitations added to substitute claims 22–24 are narrowing limitations. Paper 55, 1. Petitioner does not contest that the remaining limitations are narrowing. Paper 45, 4–7. We agree that the remaining limitations are narrowing. Therefore, for the foregoing reasons, we determine that Patent Owner’s proposed substitute claims 22–24 comply with 37 C.F.R. § 42.121(a)(2).

*b. Definiteness of Substitute Claims*

Under 35 U.S.C. § 112, ¶ 2, “[t]he specification shall conclude with one or more claims particularly pointing out and distinctly claiming the subject matter which the applicant regards as his invention.” The U.S. Supreme Court read “§ 112, ¶ 2 to require that a patent’s claims, viewed in light of the specification and prosecution history, inform those skilled in the art about the scope of the invention with reasonable certainty.” *Nautilus, Inc. v. BioSig Instruments, Inc.*, 134 S.Ct. 2120, 2129 (2014). We apply this standard in the context of our use of the broadest reasonable interpretation standard for claim construction (37 C.F.R. § 42.100(b)) and, given that the

IPR2013-00159  
Patent 8,273,183 B2

challenged claim terms were introduced in a motion to amend claims, in the absence of prosecution history with respect to the language of the proposed substitute claims.<sup>7</sup> Petitioner argues that the substitute claims are indefinite. Paper 45, 7–9. We disagree.

Petitioner contends that, because substitute claim 24 only refers to “at least a front pair of wheels, each wheel axially mounted transverse to the longitudinal axis” of said apparatus, this claim fails to provide proper antecedent basis in the claim for the term “*the* transverse axial mountings.” *Id.* at 7 (emphasis added). Claim 22 similarly recites that “rotationally-mounted supports [are] axially mounted transverse to a longitudinal axis of said apparatus.” In particular, Petitioner contends that “[i]t is unclear from the claim what is meant by the term ‘transverse axial mountings’ (i.e., whether the mountings are part of, connected to, or entirely separate from supports or wheels).” *Id.* Petitioner, however, confuses the requirement for antecedent basis with the construction of the term. Here, we are persuaded that the description of the supports or wheels as “axially mounted transverse to a longitudinal axis” provides sufficient antecedent basis for the later reference to “the transverse axial mountings.” *See* Paper 55, 3.

Petitioner further contends that, because substitute claims 22 and 24 refer to “a longitudinal axis” and because the term “longitudinal axis” is undefined, these claims are indefinite. Paper 45, 8 (citation omitted). In particular, Petitioner contends that “it is unclear *when* the supports of claim

---

<sup>7</sup> *See In re Packard*, 751 F.3d 1307, 1325 (Fed. Cir. 2014) (Plager, J., concurring) (“[U]nlike courts which have a full prosecution record to consider, the prosecution record before the USPTO is in development and not fixed during examination, and the USPTO does not rely on it for interpreting claims.”).

IPR2013-00159  
Patent 8,273,183 B2

22 or the wheels of claim 24 are transverse to the longitudinal axis.” *Id.* (emphasis added). Patent Owner argues that the “longitudinal axis” is described in the Specification. Paper 55, 3 (citing, e.g., Ex. 1006, Figs. 33–36 (depicting double headed arrow)); *see also* Ex. 1006, col. 4, ll. 8–11 (the cleaner may move “on supporting wheels, rollers or tracks that are aligned *with the longitudinal axis* of the cleaner body when it moves in a straight line” (emphasis added)). Further, as Patent Owner correctly notes, the supports (claim 22) or the wheels (claim 24) are axially mounted transverse to the longitudinal axis, but the supports or wheels themselves are not recited as “transverse to the longitudinal axis.” Paper 55 3–4; *see* Paper 45, 8. Thus, substitute claims 22 and 24 are not indefinite for the reasons proposed by Petitioner.

Petitioner contends that substitute claim 23 is indefinite (1) because the claim recites “a force vector” and it is not clear whether this is the same as or a different “force vector” from that recited in its base claim, claim 22; and (2) because the claim recites “the plane” without providing antecedent basis for the “plane.” Paper 45, 8–9. In particular, Petitioner contends that “many force vectors can potentially be ‘directed to pass proximately to and rearwardly of the plane.’” *Id.* at 9 (citing Ex. 1010 ¶ 26). As with original claims 7 and 8, we construe the term “a force vector” of substitute claim 23 to refer to the force vector in its base claim. With respect to the recitation of “the plane,” there are only a limited number of planes which may contain the transverse axial mounting and be oriented, such that the force vector is directed to pass “proximately to and rearwardly of the plane.” In particular, the plane may be parallel to the direction of the vector, but if the plane is angled toward the vector, the degree of offset is limited by the length, i.e.,

IPR2013-00159  
Patent 8,273,183 B2

the magnitude, of the resultant force vector. Thus, Patent Owner's claim may be broad in scope, but the breadth of a claim is not to be equated with indefiniteness. *See e.g., In re Miller*, 441 F.2d 689, 693 (CCPA 1971). Thus, substitute claim 23 is not indefinite for the reasons proposed by Petitioner.

*c. Written Description for Substitute Claims*

37 C.F.R. § 42.121(b)(1) requires the patent owner to set forth in a motion to amend "the support in the original disclosure of the patent for each claim that is added or amended." *See Nichia Corporation v. Emcore Corporation*, IPR2012-00005, slip op. 3 (PTAB June 3, 2013) (Paper 27). Substitute claim 23 recites that "a resultant force vector in the water jet discharged from said at least one discharge opening that is directed to pass proximately to and rearwardly of the plane of the axis of rotation of the pair of wheels at the front portion of the apparatus." Paper 42, 3. Petitioner contends that "Patent Owner has failed to identify where this language is recited *in haec verba* and further failed to explain why one of ordinary skill in the art would have recognized that the inventor possessed the claimed subject matter." Paper 45, 10. As the U.S. Court of Appeals for the Federal Circuit explains, however,

The test for determining compliance with the written description requirement is whether the disclosure of the application as originally filed reasonably conveys to the artisan that the inventor had possession at that time of the later claimed subject matter, *rather than the presence or absence of literal support in the specification for the claim language* . . . The content of the drawings may also be considered in determining compliance with the written description requirement.



IPR2013-00159  
Patent 8,273,183 B2

*In re Kaslow*, 707 F.2d 1366, 1375 (Fed. Cir. 1983) (emphasis added) (citations omitted). Consequently, Patent Owner is not required to identify where this language is recited *in haec verba* in order to satisfy the written description requirement.

Patent Owner argues that the recitations of substitute claim 23 conforms the language of that claim to the language proposed in substitute claim 22. Paper 45, 6–7. We agree. Substitute claim 22 recites that “a resultant force vector that is directed to *a position that is proximate to and rearwardly displaced from a line passing through the transverse axial mountings* of the front rotationally-mounted supports.” Paper 42, 3 (emphasis added). Original claims 7 and 8 described the rotationally-mounted supports as a pair of wheels and the resultant force vector as passing *through* the plane of the axis of rotation of the pair of wheels. Ex. 1006, col. 24, ll. 52–63. Further, the orientation of the plane of the axis of rotation of the pair of wheels is implicit in the drawings, given the angle of the resultant force vector. *E.g., id.* Fig. 9; *see Enzo Biochem, Inc. v. Gen-Probe Inc.*, 323 F.3d 956, 969 (Fed. Cir. 2002) (“the written description requirement is satisfied by the patentee’s disclosure of ‘such descriptive means as words, structures, figures, diagrams, formulas, etc., that fully set forth the claimed invention.’” (citation omitted)). Therefore, we determine that substitute claim 23 satisfies the written description requirement.

## 2. Patentability Over the Prior Art

An *inter partes* review is neither a patent examination proceeding nor a patent reexamination proceeding. In a motion to amend claims, the patent owner, as the movant, bears the burden of establishing the patentability of the proposed substitute claims over the prior art of record and also other

IPR2013-00159  
Patent 8,273,183 B2

prior art known to Patent Owner. *Idle Free Systems, Inc. Bergstrom, Inc.*, IPR2012-00027, slip op. 7 (PTAB June 11, 2013) (Paper 26) (informative). We deny the Replacement Corrected Motion to Amend Claims because, for the reasons below, we are not persuaded that Patent Owner has demonstrated the patentability of the proposed substitute claims over a ground of unpatentability involving Henkin and Myers.

*a. Construction of Substitute Claims*

Initially, we note that Patent Owner does not propose a construction for the claim terms added to original claims 1, 8, and 20 by substitute claims 22–24, respectively. Paper 55, 4–5. Patent Owner again addresses the definition of “a front portion” and “a forward direction” in the substitute claims and asserts that “[t]he proposed amendments require that the ‘front’ is not variable.” *Id.* at 4. We disagree.

As with original claim 1, substitute claim 22 continues to define the “front portion as defined by the direction of movement of the apparatus when propelled by a water jet.” Paper 42, 2. Claim 24 adopts a similar recitation from original claim 20. *Id.* at 4. Consequently, we again construe the front portion as variable with the direction of movement “when propelled by a water jet.”

Substitute claim 22 recites that rotationally-mounted supports are “axially mounted transverse to a longitudinal axis of said apparatus.”<sup>8</sup> *Id.* at 2. Substitute claim 24 recites a similar limitation in which the supports are pairs of wheels. *Id.* at 4. Patent Owner proposes that we construe longitudinal axis as an axis which extends along the length of the apparatus

---

<sup>8</sup> Substitute claim 23 depends from substitute claim 22 and recites that the supports are pairs of wheels. Paper 42, 3.

IPR2013-00159  
Patent 8,273,183 B2

in the direction of movement. Paper 55, 3-4. Patent Owner also proposes that “the ‘longitudinal axis’ is a real or imaginary straight line running or placed lengthwise around which the parts of the apparatus are symmetrically arranged.” Paper 55, 3. Because the apparatus may move in any direction (*see* Ex. 1006, col. 5, ll. 4–9 (apparatus with “controlled random motions with respect to the bottom surface of the pool or tank”)), this construction means that the orientation of the longitudinal axis is variable. Petitioner does not contest this construction (*see* Paper 45, 8), and we adopt this construction of the term “longitudinal axis.”

Patent Owner does not propose a construction for “transverse axial mountings.” Nevertheless, Patent Owner proposes that

A line defined as extending transversely between the transverse axial mountings of the front pair of wheels is present either for wheels that have a common axle 32 which extends transversely across the longitudinal axis of the cleaning apparatus (’183 Patent, Figs. 9, 10) or are individually mounted to an independent axle that does not extend completely across the cleaning apparatus. *Id.*, Figs. 33–36, 39–44.

Paper 42, 6. A relevant definition of “transverse” is “lying, situated, placed, etc. across; crossing from side to side; opposed to LONGITUDINAL.” WEBSTER’S NEW WORLD DICTIONARY (Ex. 3002) at 1422. Petitioner does not propose a construction for this term. Therefore, we construe the term “transverse axial mountings” as devices for mounting rotationally-mounted supports or wheels on opposite sides of a longitudinal axis. Because both the front portion and the longitudinal axis may vary with the direction of movement, a transverse line across the longitudinal axis or between supports or wheels also may vary with the direction of movement.

IPR2013-00159  
Patent 8,273,183 B2

Further, substitute claim 22 recites that “rotationally-mounted supports axially mounted transverse to a longitudinal axis of said apparatus and coupled proximate the front and rear portions of the housing *to control* the directional movement of said apparatus over the submerged surface.” Paper 42, 2 (emphasis added). Thus, substitute claim 22 recites that the supports *control* the directional movement although the apparatus may be *propelled* by a water jet. Substitute claim 24 recites that such control is supplied by wheels, rather than supports.

Although each of substitute claims 22–24 recites that the apparatus comprises “a stationary directional discharge conduit,” this limitation appears in original claim 1. We construe this limitation in the same manner that we construed it with respect to the original claims. *See supra* Section II.A.1. Consequently, we remain unpersuaded that the front portion is not variable, e.g., is in constant alignment with the water jet which is propelling the apparatus in a forward direction. *See* Paper 28, 5.

Finally, substitute claim 22 recites that “said predetermined angle is inclined upwardly with respect to the surface beneath the apparatus to produce a resultant force vector that is directed to a position that is proximate to and rearwardly displaced from a line passing through the transverse axial mountings of the front rotationally-mounted supports.” Paper 42, 2. Substitute claim 24 recites a similar limitation referring to pairs of wheels, instead of supports. *Id.* at 4–5. Consistent with the constructions set forth above, we construe the line passing through the transverse axial mountings as varying with the direction of movement. Hence, as the apparatus changes direction, each of the front portion, the longitudinal axis,

IPR2013-00159  
Patent 8,273,183 B2

and the line passing through the transverse axial mountings “of the *front* rotationally-mounted supports” will vary.

*b. Obviousness over Henkin and Myers*

Patent Owner argues that substitute claims 22–24 are patentable over Henkin and Myers. Paper 42, 11–13. In particular, Patent Owner argues that “[n]either Henkin nor Myers suggest an apparatus with the ‘resultant force vector that is directed to a position that is proximate to and rearwardly displaced from a line passing through the transverse axial mountings of the front rotationally-mounted supports’ (claim 22) or the ‘front pair of wheels’ (claim 24).” Paper 42, 11–12 (citing Ex. 2016 ¶ 77) (emphasis omitted).

Patent Owner argues that the Specification of the ’183 Patent discloses that the resultant force vector enables the apparatus to maintain consistent traction with the pool surface, advances the cleaner in a forward direction, and allows the apparatus to maintain proper orientation when contacting a vertical wall that is normal to the horizontal bottom surface beneath the cleaner. Paper 42, 12 (citing Ex. 1006, col. 10, l. 60–col. 11, l. 3; col. 10, ll. 47–51; col. 25, ll. 10–13; Ex. 2016 ¶ 78). In particular, Patent Owner argues that:

When the apparatus comes into contact with a vertical surface normal to the horizontal bottom surface, the angle and direction, i.e., positioning of the resultant force vector  $V_r$ , ensures that the apparatus does not flip up and disrupt the cleaning pattern. Paper 42, 12 (citing Ex. 2016 ¶ 78). If the resultant force vector is directed forward of the transverse axial line of the front rotationally-mounted supports, the rear end of the apparatus can be impelled to flip upwards and rotate forward towards the vertical sidewall, thereby displacing and hindering the forward ascent of the apparatus up the sidewall. *Id.* ¶¶ 36, 79.

IPR2013-00159  
Patent 8,273,183 B2

Paper 42, 12.

As Petitioner notes, “Henkin discloses a resultant force vector having th[e] very same purpose” that Patent Owner attributes to the structure of the substitute claims. Paper 45, 13. Patent Owner states that “[t]he angle [of adjustable nozzle 90] is selected to yield both a downward thrust component, *i.e.*, normal to the vessel surface, for providing traction and a forward component which aids in propelling the apparatus. Set means can be provided for holding the selected angle of the nozzle and valve means for varying the flow rate through the nozzle, 90.” Paper 28, 8 (citing Ex. 2016 ¶ 64 (citing Ex. 1002, col. 5, ll. 15–27)). Henkin specifically teaches that the selected angle of nozzle 90 also “facilitates the car *climbing vertical surfaces* and working itself out of corners.” Ex. 1002, col. 5, ll. 22–24 (emphasis added).

Patent Owner argues Henkin and Myers did not recognize or try to solve the problem it identified. Paper 42, 13 (citing Ex. 2016 ¶ 80). Patent Owner argues that “[n]either Henkin nor Myers suggest or otherwise provide a person of ordinary skill in the art with any reason to direct the resultant force vector proximate to and rearwardly displaced from a line passing through the transverse axial mountings of the front rotationally-mounted supports (e.g., a front pair of wheels), as recited in proposed substitute claim 22 or 24.” Paper 42, 12–13 (citing Ex. 2016 ¶¶ 63, 79). As discussed above with respect to the original claims, we disagree. Henkin describes using the downward resultant force for a substantially similar purpose to the ’183 Patent. Paper 70, 15:20–16:2; *compare* Ex. 1006, col. 10, ll. 60–64, *with* Ex. 1002, col. 5, ll. 19–23. Consequently, we find that with respect to the additional limitations recited in the substitute claims, there are a finite

IPR2013-00159  
Patent 8,273,183 B2

number of predictable solutions and that the subject matter of the substitute claims is not the product of innovation, but of ordinary skill and common sense. *See KSR*, 550 U.S. at 421; *see also* Paper 70, 16:22–24 (“The patent owner has not put forward any reason that this particular technology area is so specialized that [the combinations of the teachings of Henkin and Myers] were neither predictable or beyond the person of ordinary skill.”).

Consequently, Patent Owner’s Replacement Corrected Motion to Amend Claims requesting entry of substitute claims 22–24 is *denied* for failing to demonstrate that the substitute claims are patentable over Henkin and Myers.<sup>9</sup>

#### *D. Motion to Exclude Evidence*

In Patent Owner’s Motion to Exclude Evidence, Patent Owner moves to exclude (1) certain paragraphs of the declaration of Petitioner’s declarant, Mr. McQueen (*i.e.*, Ex. 1009 ¶¶ 16–21, 23, 26); and (2) the declaration of Petitioner’s declarant, Dr. Homayoon Kazerooni (Ex. 1010). Paper 58, 1. As noted above, Petitioner filed an Opposition to Patent Owner’s Motion to Exclude Evidence (Paper 61), and Patent Owner filed a Reply Memorandum in Support of its Motion to Exclude Evidence (Paper 62). The motion is *granted-in-part* and *denied-in-part*.

---

<sup>9</sup> Petitioner notes that “Patent Owner did not identify or assert any secondary considerations of non-obviousness with respect to substitute claims 22-24.” Paper 45, 15. Nevertheless, we were not persuaded by Patent Owner’s arguments regarding secondary considerations with respect to the challenged claims.

IPR2013-00159  
Patent 8,273,183 B2

*1. Declaration of Mr. McQueen*

With regard to the Declaration of Mr. McQueen, Patent Owner requests that we exclude (1) paragraphs 23 and 26 because these paragraphs rely on information that was not produced or for which English-language translations were not provided; (2) paragraphs 16–18 because these paragraphs rely on information concerning meetings which Mr. McQueen did not attend; and (3) paragraphs 19–21 because these paragraphs respond to Mr. Erlich’s comments concerning a meeting (Ex. 2016 ¶ 49) that Mr. McQueen did not attend. Paper 58, 3–8. Regarding the Declaration of McQueen, Petitioner contends that Patent Owner’s objections were insufficient or untimely. Paper 61, 2–3. In addition, regarding paragraph 26, Petitioner contends that Mr. McQueen’s statements concerning certain unproduced user-studies relate to his recollection of the studies, rather than the studies themselves. *Id.* at 4. Further, Petitioner acknowledges that it could not locate and produce the studies. *Id.* at 5. Petitioner maintains, however, that Mr. McQueen’s testimony is admissible without the supporting documents. *Id.* (citing F.R.E. 602).

Patent Owner states that it first objected to the Declaration of Mr. McQueen on March 16, 2014, four business days after service of the declaration. Paper 58, 3; Paper 62, 1. Further, Petitioner’s production and filing of documents in this case was piecemeal and ultimately incomplete. *See* Paper 61, 5; Paper 62, 1–2. Given the Petitioner’s actions in this case, we determine that Petitioner was adequately and timely informed of Patent Owner’s objections to the Declaration of Mr. McQueen. *See* 37 C.F.R. § 42.5(a).



IPR2013-00159  
Patent 8,273,183 B2

With respect to paragraph 26 of the Declaration of Mr. McQueen, we determine that Patent Owner's objections go to the weight that we accord to Mr. McQueen's testimony, rather than the admissibility of this paragraph of the Declaration of Mr. McQueen. We are capable of according the appropriate weight to testimony, for which Petitioner is unable to provide support. Therefore, we deny Patent Owner's request to exclude paragraph 26 of the Declaration of Mr. McQueen.

With respect to paragraph 23 of the Declaration of Mr. McQueen, Mr. McQueen refers to an engineering study, including a flow analysis, in the Spring and Summer of 2007 by a third party engineering company; three Enveloppe Soleau filed with the French National Industrial Property Institute on August 20, 2007; and nine French patent applications filed in December 2007. Ex. 1009 ¶ 23. Of these documents, Patent Owner states that only one of the three Enveloppe Soleau was produced (Ex. 1014B). Paper 58, 4. Nevertheless, this exhibit was not filed with the Board. Further, although Petitioner appears to have produced certain supporting documents (e.g., Exhibits 1014A, 1014B, 1015A, and 1015B) to Patent Owner, Patent Owner asserts that these documents were produced in French, without accompanying English-language translations. *Id.* at 5–6.

In acknowledgment of the deficiencies in its production of documents to the Patent Owner and in its filing of documents with the Board, Petitioner offers to strike portions of paragraph 23 of the Declaration of Mr. McQueen. Paper 61, 4–5. Petitioner's offer is insufficient. Petitioner's declarant states that “Zodiac had a third party engineering company *conduct an engineering study, including a flow analysis on the inverted pump design and engineering drawings.* This analysis took place in the spring and summer of

IPR2013-00159  
Patent 8,273,183 B2

2007.” Ex. 1009 ¶ 23 (emphasis added). Contrary to Petitioner’s assertion, these sentences relate to the content of cited documents, rather than solely to “facts that occurred.” Paper 61, 5. Therefore, we grant-in-part Patent Owner’s motion to exclude paragraph 23 of the Declaration of Mr. McQueen and exclude all of paragraph 23 of Mr. McQueen’s declaration, except for the first sentence: “Zodiac’s development of the Polaris 9300/9400 line began in January 2007.” We accord the appropriate weight to this statement in the Declaration of Mr. McQueen.

With respect to paragraphs 16–21 of the Declaration of Mr. McQueen, Patent Owner objects that Mr. McQueen’s testimony is based on his general, rather than specific, knowledge of meetings and conversations, in which he was not a participant. Paper 58, 6–8; Paper 62, 3–4. Petitioner does not dispute that Mr. McQueen did not participate in these meetings or conversations. *See* Paper 61, 7–9. Further, Petitioner contends that “Patent Owner has not introduced anything to contradict Mr. McQueen’s statement that the facts stated are within his personal knowledge.” *Id.* at 8. With respect to paragraphs 16–21 of the Declaration of Mr. McQueen, we determine that Patent Owner’s objections go to the weight that we accord to Mr. McQueen’s testimony, rather than the admissibility of these paragraphs of the Declaration of Mr. McQueen. We are capable of according the appropriate weight to this testimony. Therefore, we deny Patent Owner’s request to exclude paragraphs 16–21 of the Declaration of Mr. McQueen.

## *2. Declaration of Dr. Kazerooni*

Dr. Kazerooni’s and Mr. McQueen’s declarations were filed on the same date, March 10, 2014. Petitioner contends that Patent Owner did not object to the Declaration of Dr. Kazerooni until twenty-one (21) days after

IPR2013-00159  
Patent 8,273,183 B2

the filing of the declaration. Paper 61, 11; *see* 37 C.F.R. § 42.64(b)(1) (“[A]ny objection must be served within five business days of service of evidence to which the objection is directed.”). Patent Owner does not dispute that it failed to object in a timely manner to the Declaration of Dr. Kazerooni. *See* Paper 58, 3; Paper 61, 4–5. Because we determine that the objections to the Declaration of Dr. Kazerooni were untimely, we deny the request to exclude his declaration.

### III. CONCLUSION

We conclude that Petitioner has demonstrated by a preponderance of the evidence that (1) claims 1, 2, 13, 14, 16, and 19–21 are anticipated under 35 U.S.C. § 102(b) by Myers; (2) claims 1–5 and 19–21 are rendered obvious under 35 U.S.C. § 103(a) by Henkin and Myers; and (3) claims 1–9 and 19–21 are rendered obvious under 35 U.S.C. § 103(a) by Pansini and Myers. Further, Patent Owner’s Replacement Corrected Motion to Amend Claims is *denied*, and Patent Owner’s Motion to Exclude Evidence is *granted-in-part* and *denied-in-part*.

This is a final written decision of the Board under 35 U.S.C. § 318(a). Parties to the proceeding seeking judicial review of this decision must comply with the notice and service requirements of 37 C.F.R. § 90.2.

### IV. ORDER

Accordingly, it is hereby:

ORDERED that claims 1–9, 14, 16, and 19–21 of the ’183 Patent are held *unpatentable*;

FURTHER ORDERED that Patent Owner’s Replacement Corrected Motion to Amend Claims is *denied*;

IPR2013-00159  
Patent 8,273,183 B2

FURTHER ORDERED that Patent Owner's Motion to Exclude Evidence is *granted-in-part* with respect to paragraph 23 of the Declaration of Mr. McQueen and *denied-in-part* with respect to the remaining challenged paragraphs of the Declaration of Mr. McQueen and with respect to the Declaration Dr. Kazerooni; and

FURTHER ORDERED that parties to the proceeding seeking judicial review of this Final Written Decision must comply with the notice and service requirements of 37 C.F.R. § 90.2.

PETITIONER:

Christopher Bright  
Gregory Yoder  
Mark Bentley  
McDERMOTT, WILL & EMERY LLP  
[cbright@mwe.com](mailto:cbright@mwe.com)  
[gyoder@mwe.com](mailto:gyoder@mwe.com)  
[mbentley@mwe.com](mailto:mbentley@mwe.com)

PATENT OWNER:

Jeffrey A. Schwab  
Anthony Coppola  
ABELMAN, FRAYNE & SCHWAB  
[jaschwab@lawabel.com](mailto:jaschwab@lawabel.com)  
[aacoppola@lawabel.com](mailto:aacoppola@lawabel.com)

# **EXHIBIT**

# **1006**

(12) **United States Patent**  
**Erlich et al.**

(10) **Patent No.:** US 8,273,183 B2  
 (45) **Date of Patent:** Sep. 25, 2012

(54) **AUTOMATED SWIMMING POOL CLEANER HAVING AN ANGLED JET DRIVE PROPULSION SYSTEM**

(75) Inventors: **Giora Erlich**, North Caldwell, NJ (US);  
**Zibor Horvath**, Springfield, NJ (US)

(73) Assignee: **Aqua Products, Inc.**, Cedar Grove, NJ (US)

(\* ) Notice: Subject to any disclaimer, the term of this patent is extended or adjusted under 35 U.S.C. 154(b) by 0 days.

(21) Appl. No.: 13/135,684

(22) Filed: Jul. 12, 2011

(65) **Prior Publication Data**

US 2011/0271983 A1 Nov. 10, 2011

**Related U.S. Application Data**

(60) Continuation of application No. 12/924,554, filed on Sep. 28, 2010, which is a division of application No. 11/606,809, filed on Nov. 29, 2006, now Pat. No. 7,827,643, which is a division of application No. 10/793,447, filed on Mar. 3, 2004, now Pat. No. 7,165,284, which is a division of application No. 10/109,689, filed on Mar. 29, 2002, now Pat. No. 6,742,613, which is a division of application No. 09/237,301, filed on Jan. 25, 1999, now Pat. No. 6,412,133.

(51) **Int. Cl.**  
**E04H 4/16** (2006.01)  
**B08B 5/00** (2006.01)

(52) **U.S. Cl.** ..... 134/6; 15/1.7

(58) **Field of Classification Search** ..... 15/1.7;  
 134/6

See application file for complete search history.

(56) **References Cited**

U.S. PATENT DOCUMENTS

3,261,371 A	7/1966	Vernon	
3,444,575 A *	5/1969	Martin	15/1
3,921,654 A	11/1975	Pansini	
3,972,339 A	8/1976	Henkin et al.	
3,979,788 A	9/1976	Strausak	
4,169,484 A	10/1979	Bonigut et al.	
4,652,366 A	3/1987	Brooks	
4,749,478 A	6/1988	Brooks	
4,776,954 A	10/1988	Brooks	
4,778,599 A	10/1988	Brooks	
4,839,063 A	6/1989	Brooks	
5,014,912 A	5/1991	Brooks	
5,317,777 A	6/1994	Stoltz	
5,569,371 A	10/1996	Perling	
7,805,792 B2	10/2010	Roumagnac	

\* cited by examiner

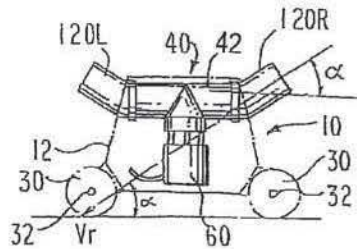
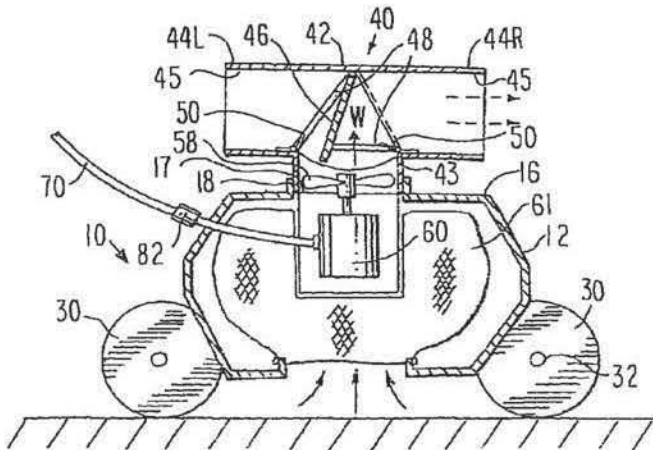
*Primary Examiner*—Randall Chin

(74) *Attorney, Agent, or Firm*—Abelman, Frayne & Schwab

(57) **ABSTRACT**

A self-propelled cleaning apparatus for cleaning a submerged surface of a pool or tank includes a housing having a front portion as defined by the direction of movement of the apparatus when propelled by a water jet, an opposing rear portion and adjoining side portions defining the periphery of the apparatus, and a baseplate with at least one water inlet. Rotationally-mounted supports are coupled proximate the front and rear portions of the housing to enable movement of the apparatus over the submerged surface. A water pump is configured to draw water and debris from the pool through the inlet for filtering. A stationary directional discharge conduit is in fluid communication with the pump and has at least one discharge opening through which a pressurized stream of water forming the water jet is directionally discharged at an acute angle with respect to the surface over which the apparatus is moving.

**21 Claims, 15 Drawing Sheets**



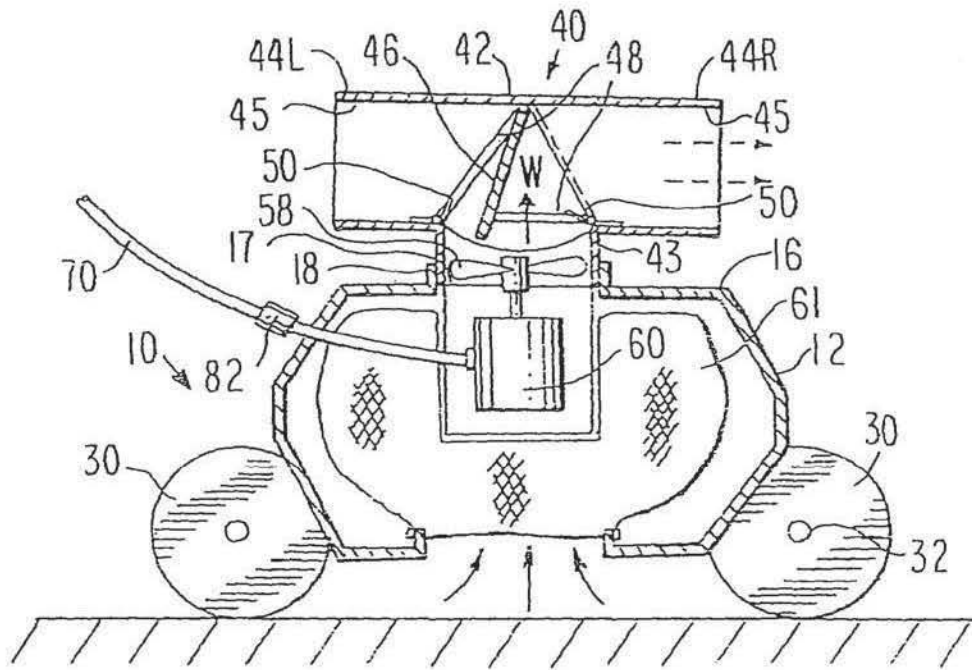


FIG. 1

FIG. 1A

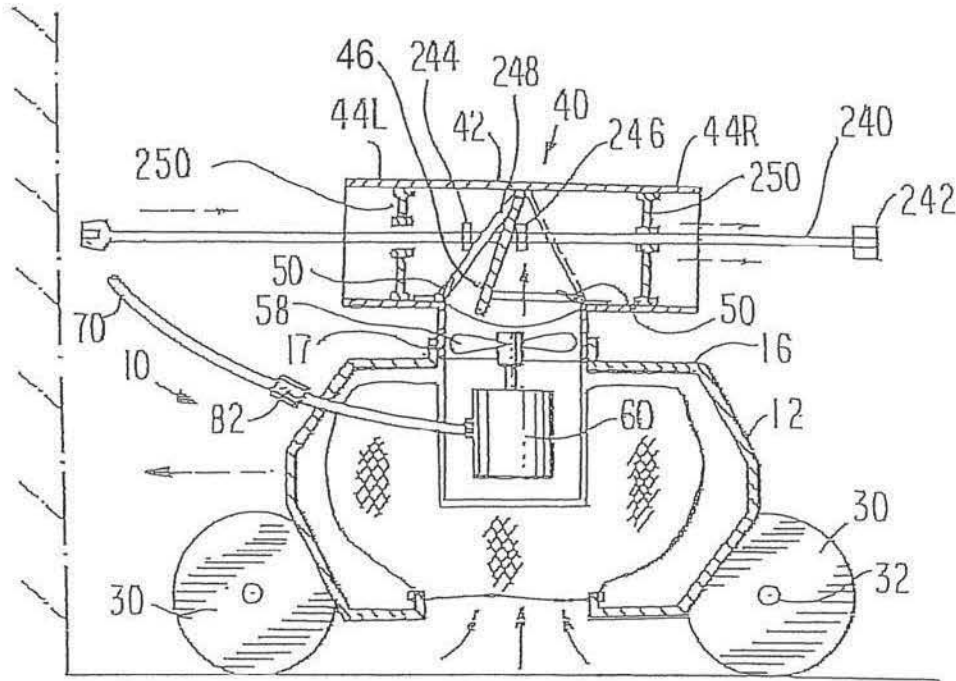


FIG. 1B

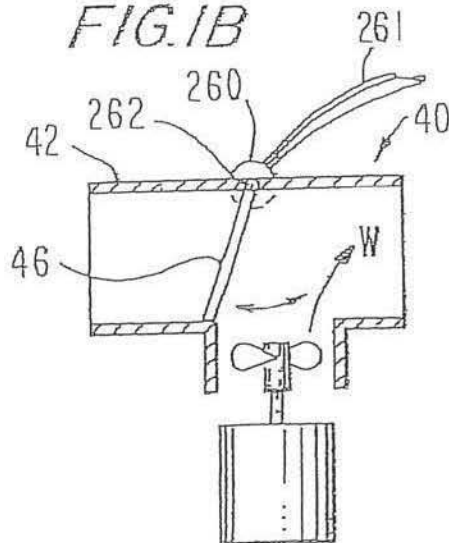




FIG. 2

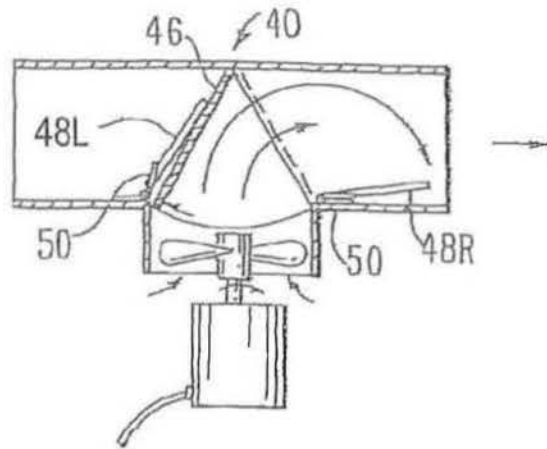


FIG. 3

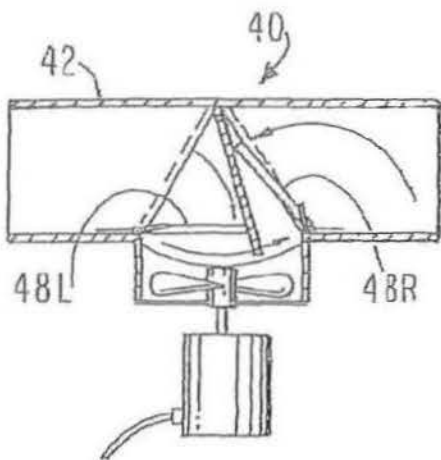


FIG. 4

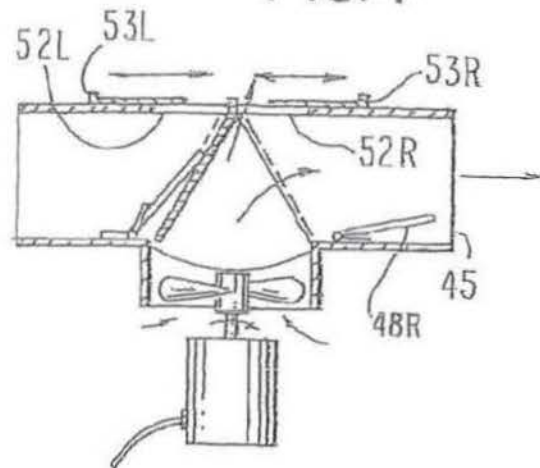


FIG. 5

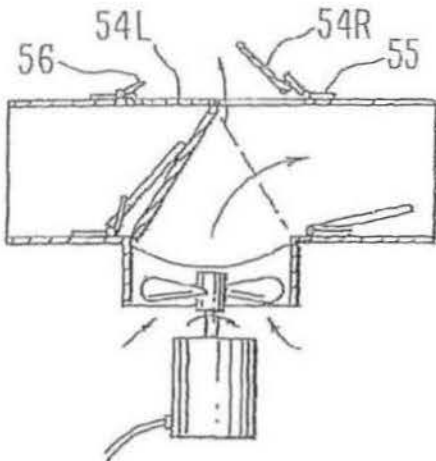


FIG. 6

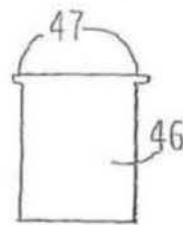
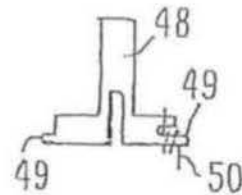
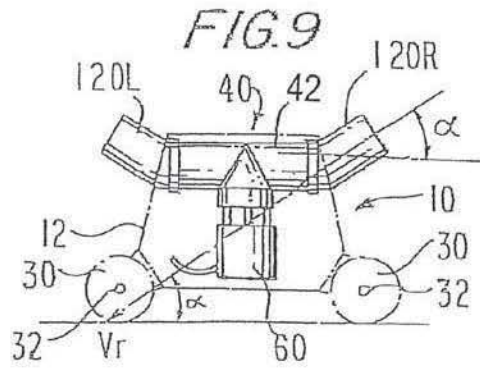
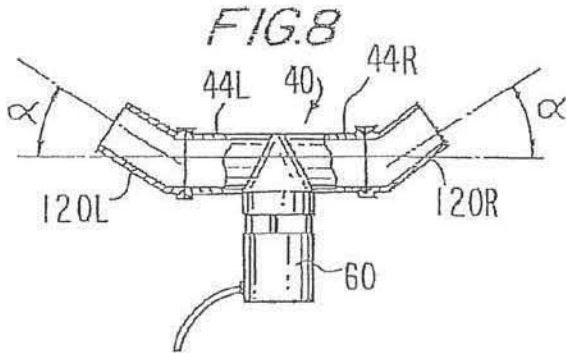
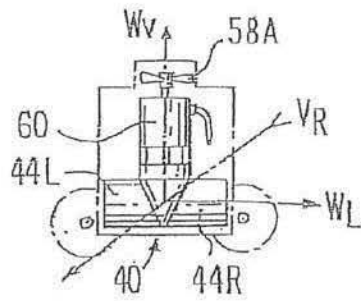


FIG. 7

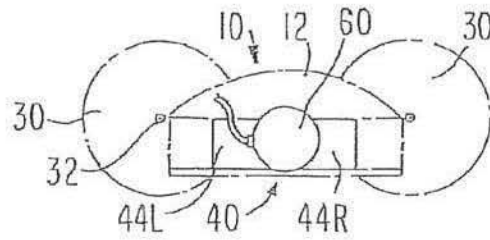




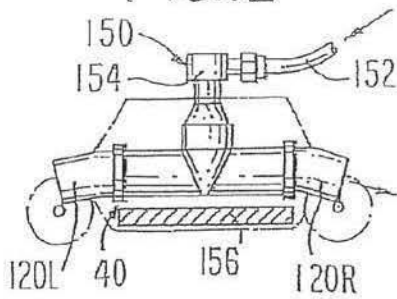
**FIG. 10**



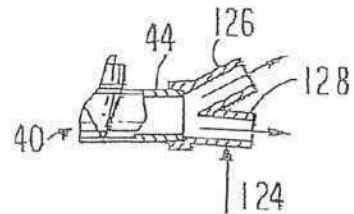
**FIG. 11**

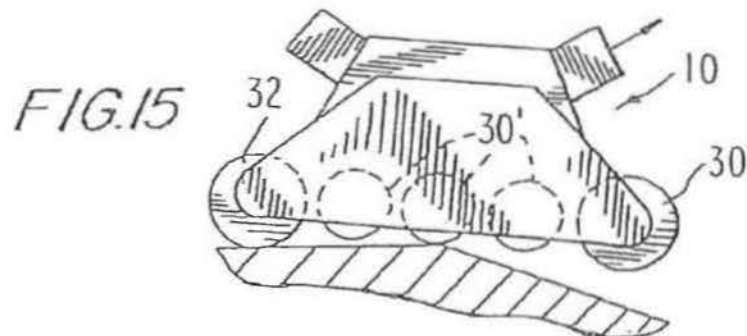
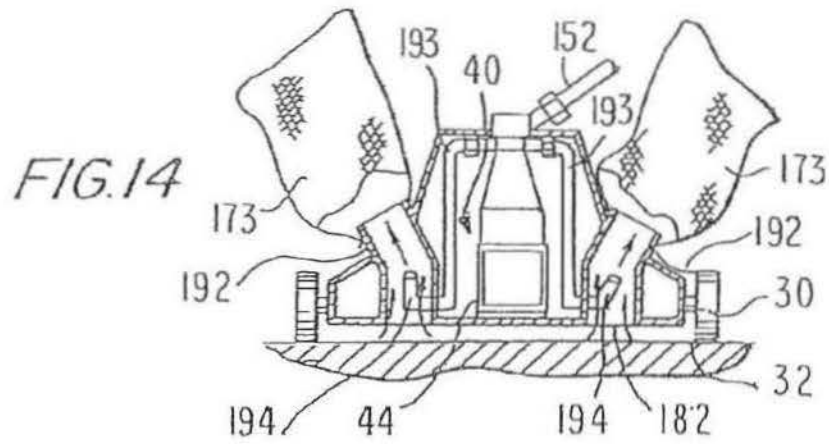
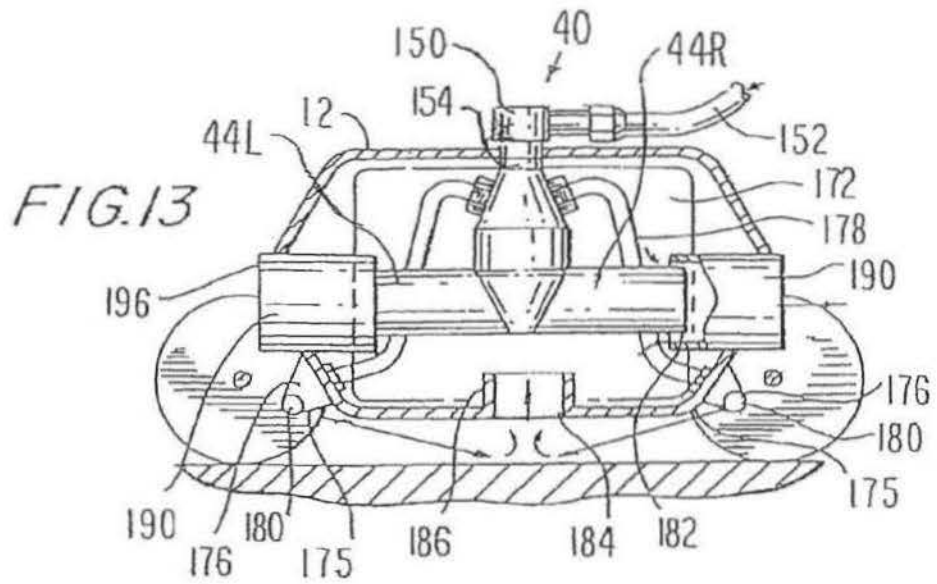


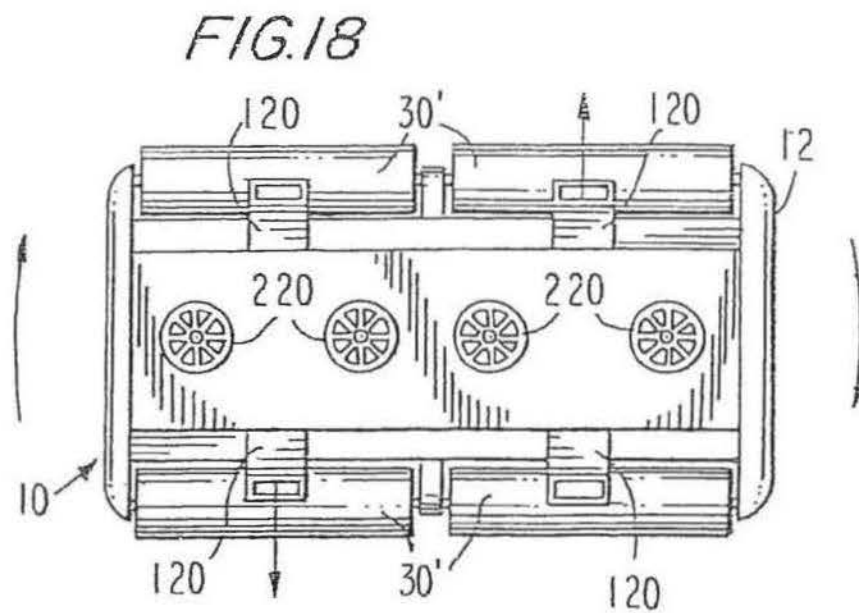
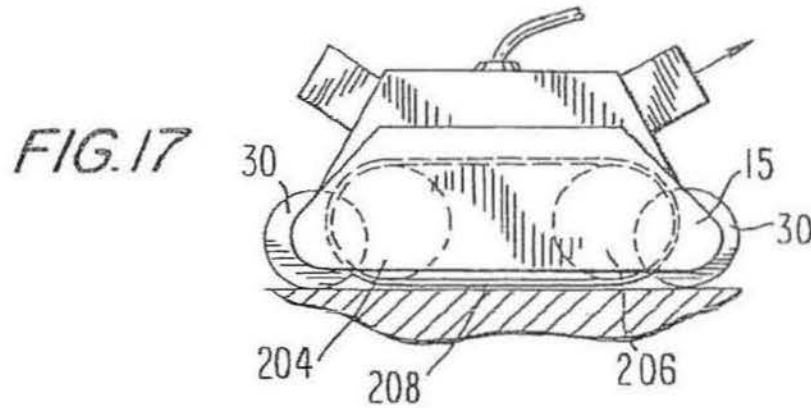
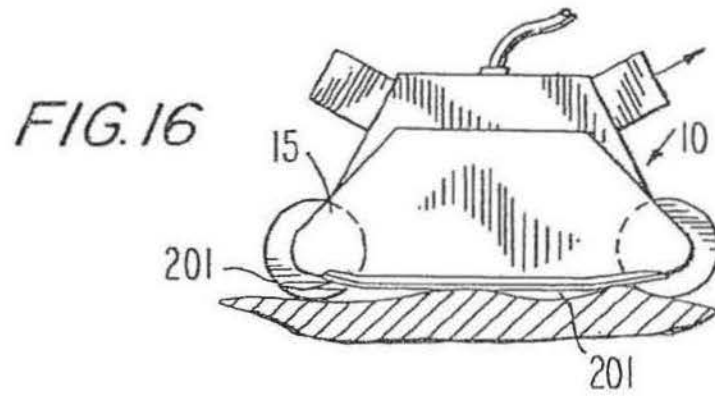
**FIG. 12**



**FIG. 12A**







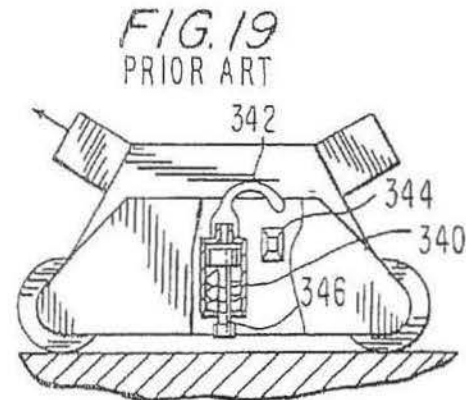
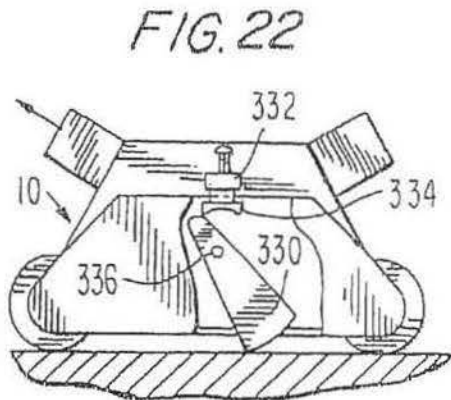
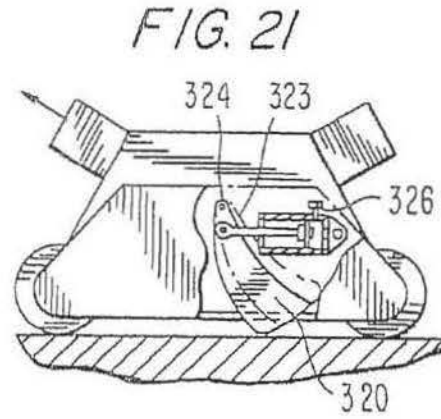
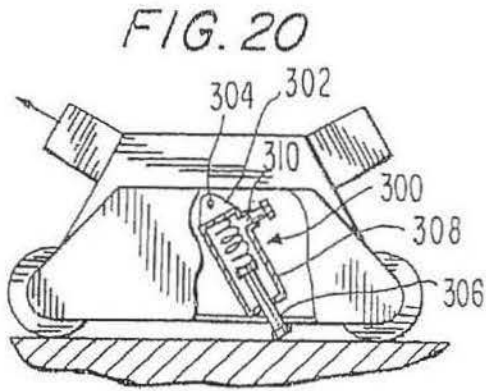


FIG. 23

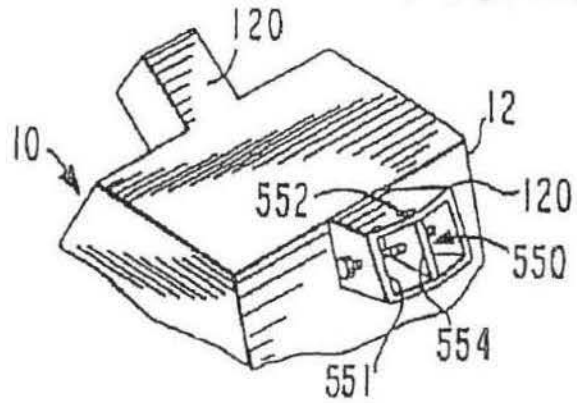


FIG. 24

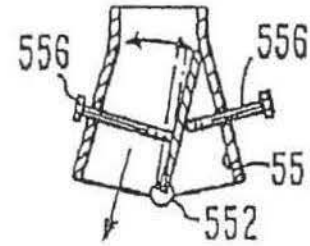


FIG. 25

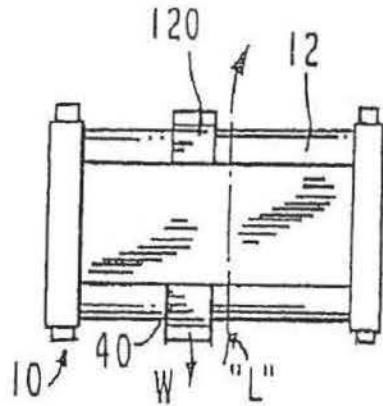
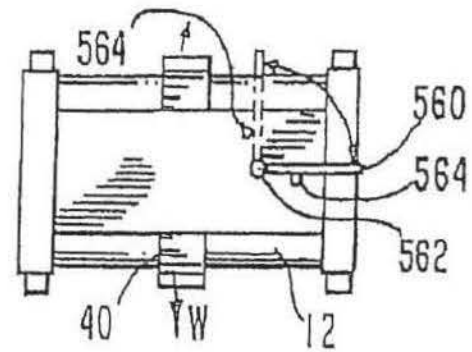
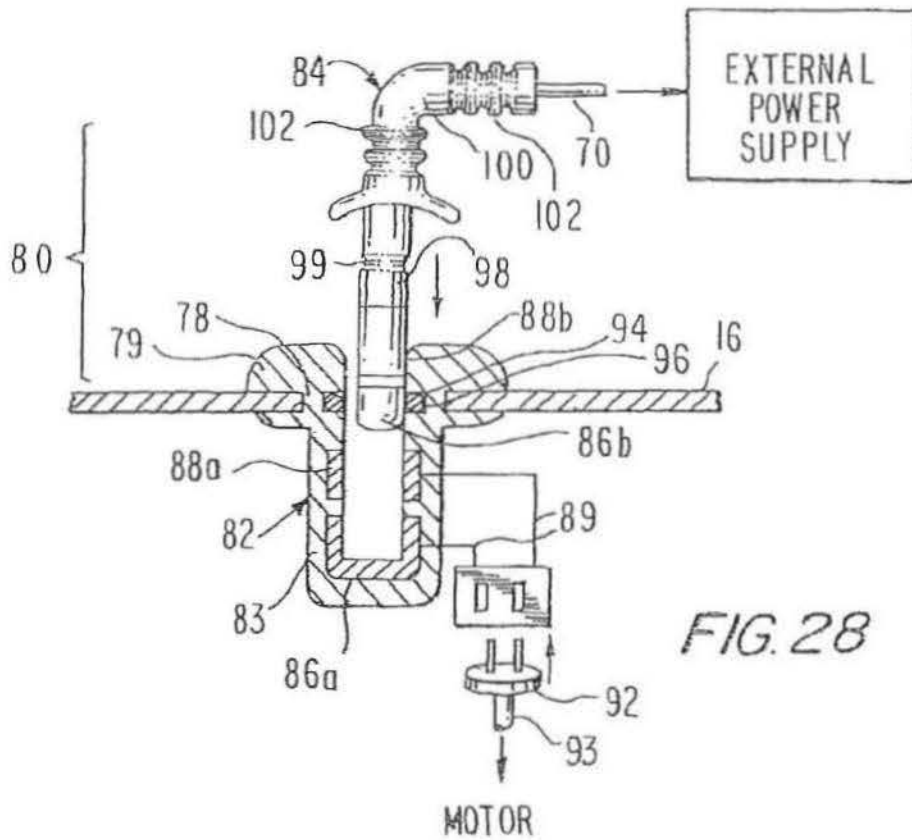
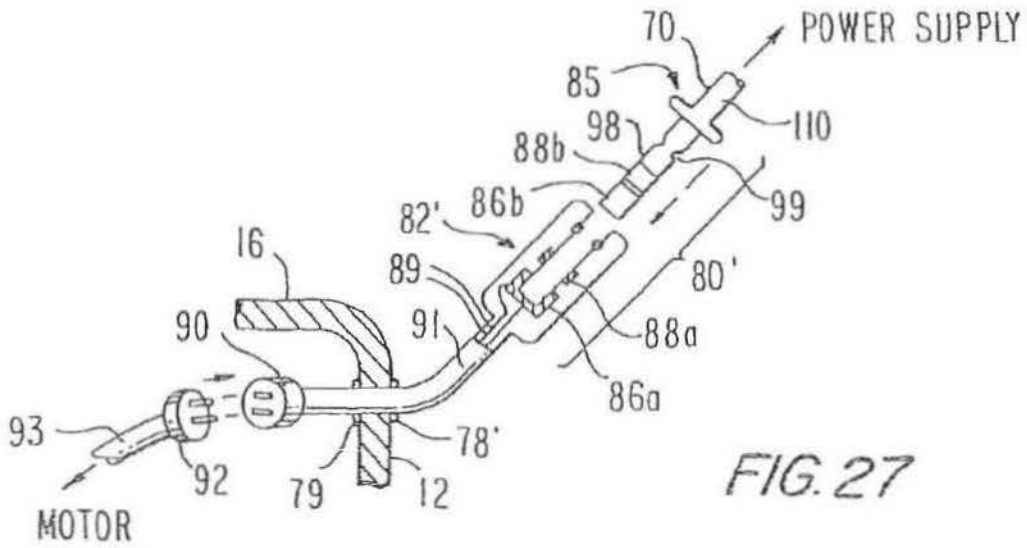


FIG. 26





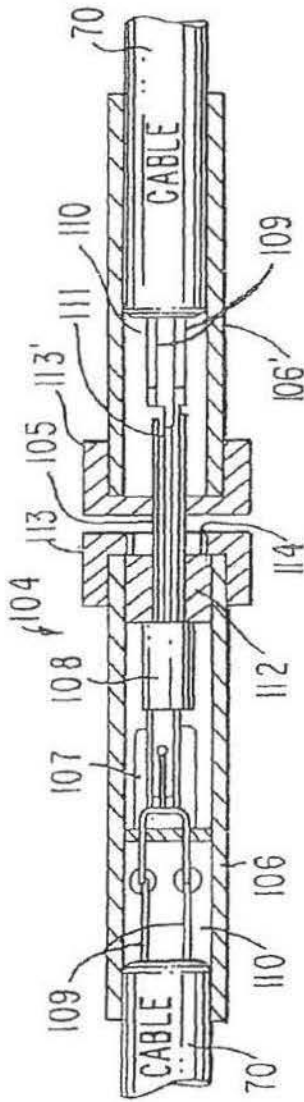


FIG. 29

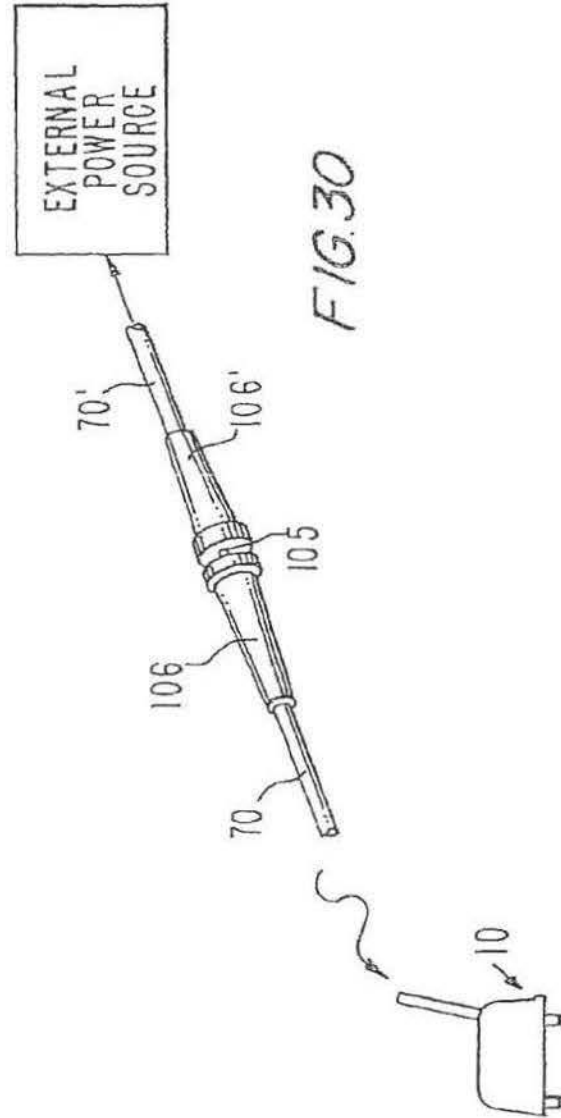


FIG. 30



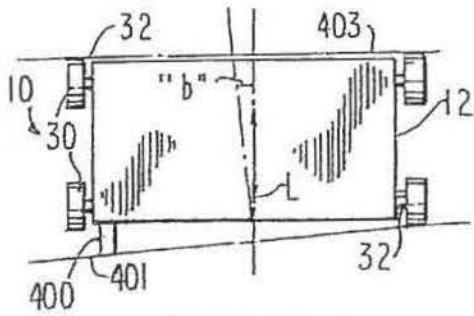


FIG. 31A  
PRIOR ART

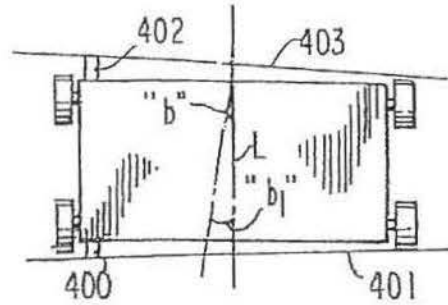


FIG. 32A  
PRIOR ART

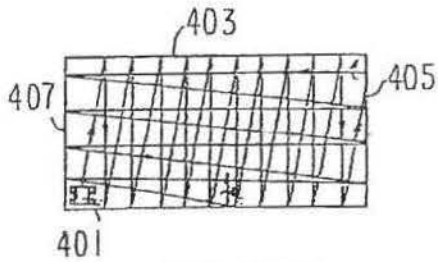


FIG. 31B  
PRIOR ART

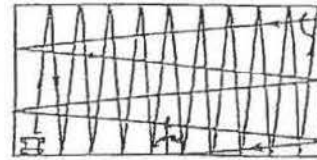


FIG. 32B  
PRIOR ART

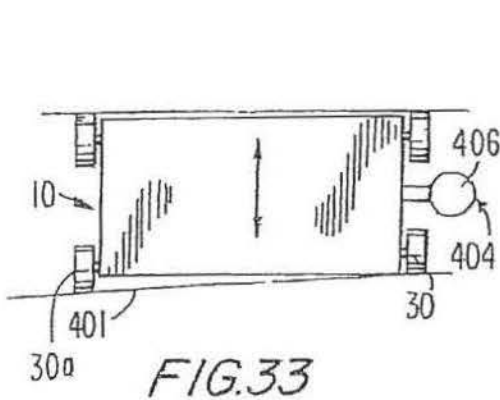


FIG. 33

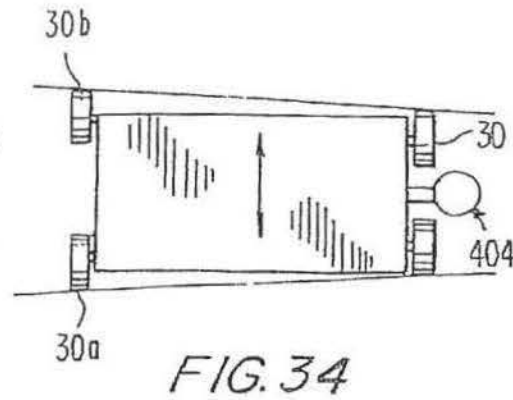


FIG. 34

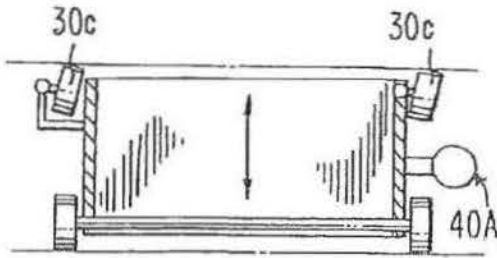


FIG. 35

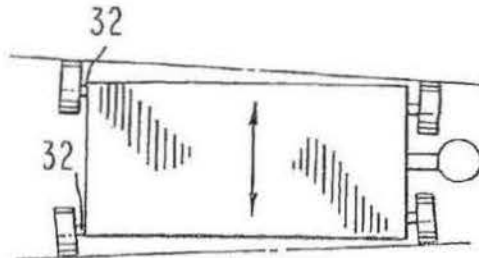


FIG. 36

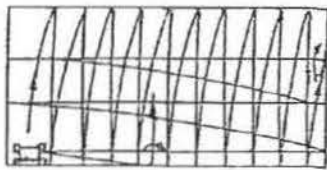


FIG. 35A

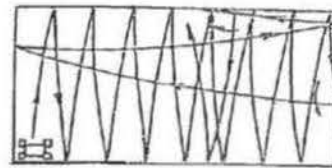


FIG. 35B

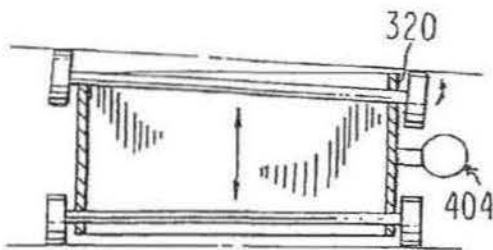


FIG. 37

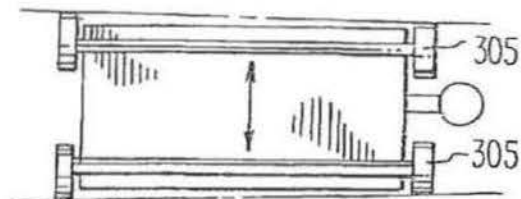


FIG. 38

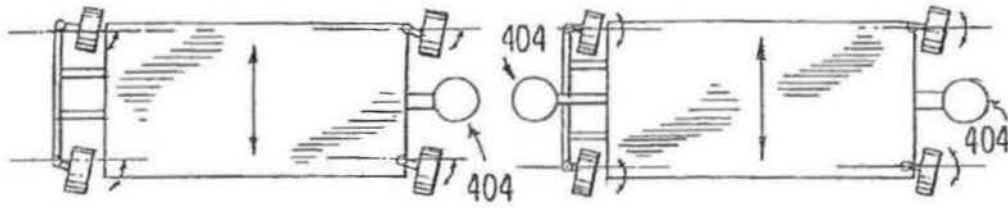


FIG. 39

FIG. 40

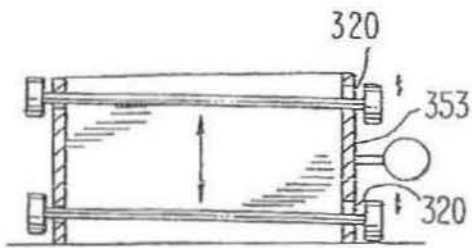


FIG. 41

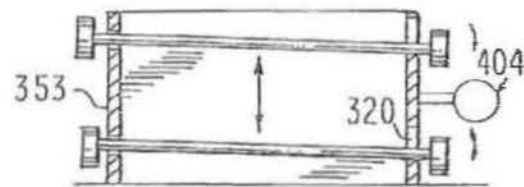


FIG. 42

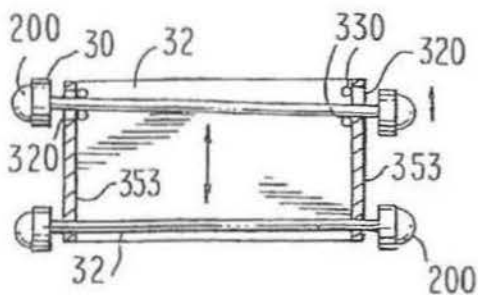


FIG. 43

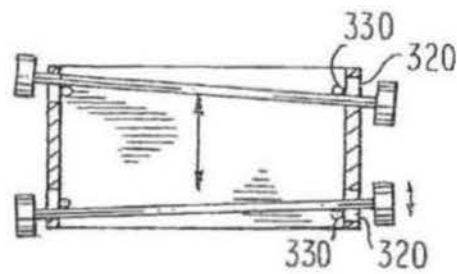
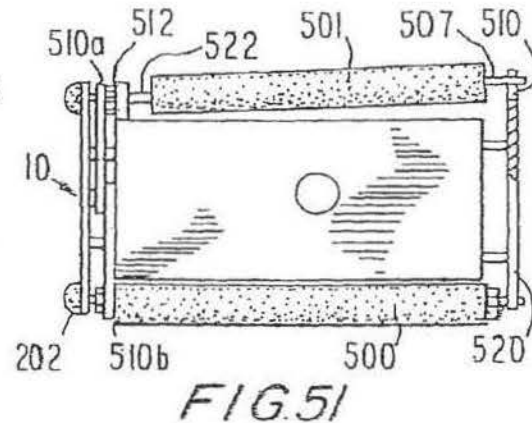
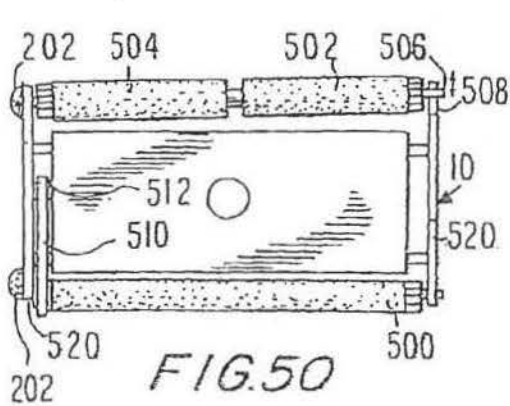
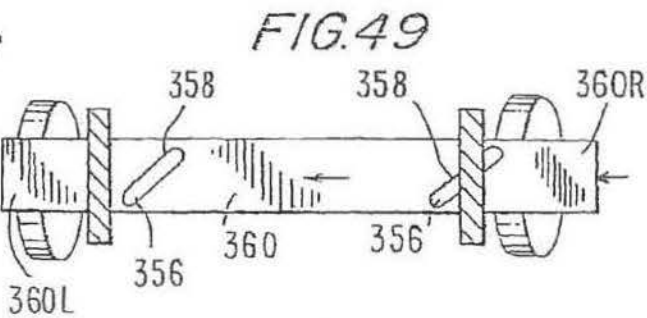
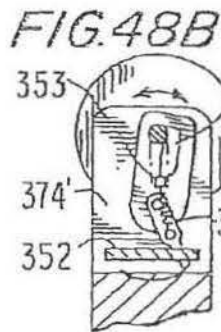
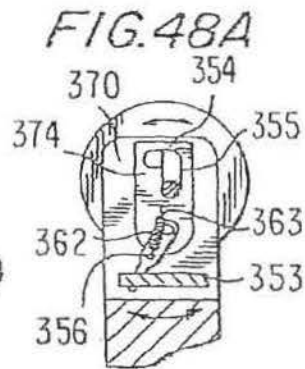
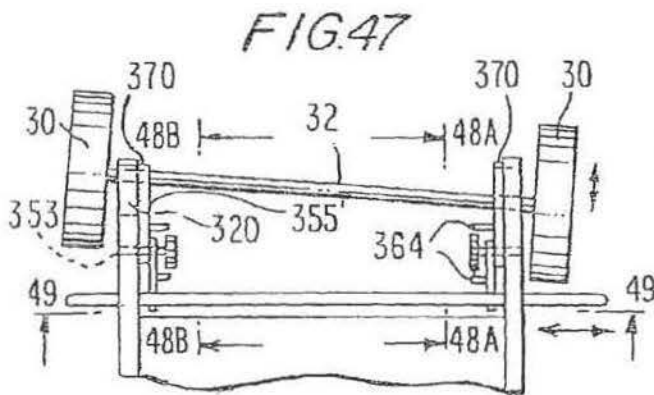
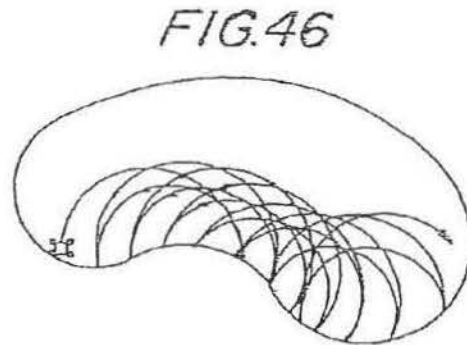
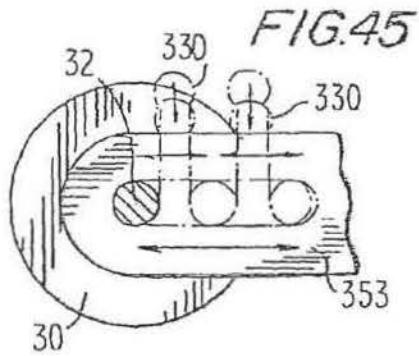


FIG. 44



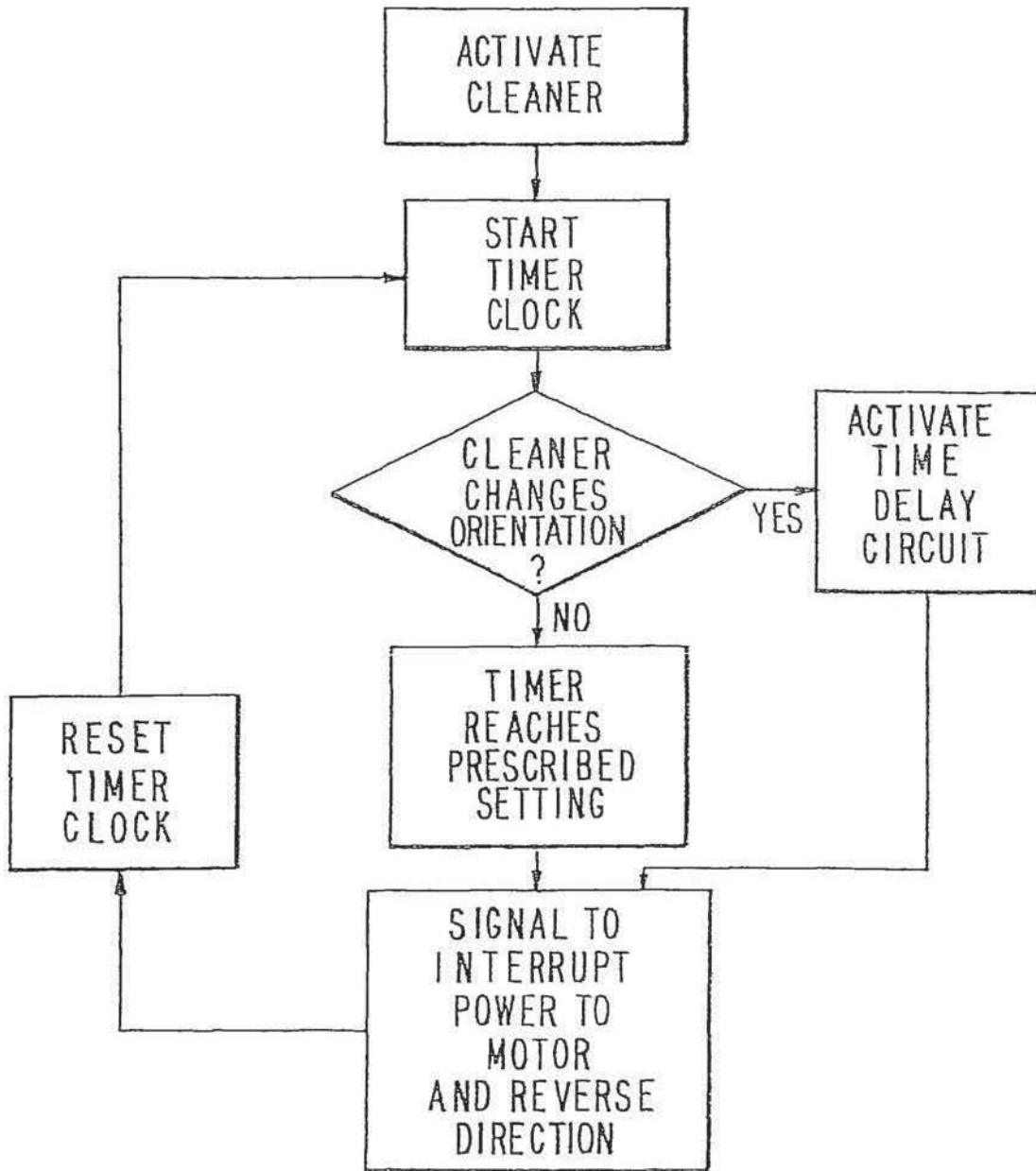


FIG. 52

US 8,273,183 B2

1

**AUTOMATED SWIMMING POOL CLEANER  
HAVING AN ANGLED JET DRIVE  
PROPULSION SYSTEM**

**CROSS REFERENCES TO RELATED  
APPLICATIONS**

This application is a continuation of U.S. application Ser. No. 12/924,554, filed Sep. 28, 2010, now pending, which is a divisional of U.S. application Ser. No. 11/606,809, filed Nov. 29, 2006, now U.S. Pat. No. 7,827,643 which is a divisional of U.S. application Ser. No. 10/793,447, filed Mar. 3, 2004, now U.S. Pat. No. 7,165,284, which is a divisional of U.S. application Ser. No. 10/109,689, filed Mar. 29, 2002, now U.S. Pat. No. 6,742,613, which is a division of U.S. Ser. No. 09/237,301 filed Jan. 25, 1999, now U.S. Pat. No. 6,412,133, the disclosures of which are incorporated herein by reference in their entireties.

**FIELD OF THE INVENTION**

The invention relates to methods and apparatus for propelling automated or robotic swimming pool and tank cleaners and for controlling the scanning or traversing patterns of the automated cleaners with respect to the bottom and sidewalls of the pool or tank.

**BACKGROUND OF THE INVENTION**

Automated or robotic swimming pool cleaners traditionally contact and move about on the pool surfaces being cleaned on axle-mounted wheels or on endless tracks that are powered by a separate drive motor through a gear train. The wheels or tracks are aligned with the longitudinal axis of the cleaner. Swimming pool cleaning robots that move on wheels generally have two electric motors—a pump motor powers a water pump that is used to dislodge and/or vacuum debris up into a filter; the drive motor is used to propel the robot over the surfaces of the pool that are to be cleaned. The drive motor can be connected through a gear train directly to one or more wheels or axles, or through a belt and pulleys to propel the cleaner; or to a water pump, which can be external to the robotic cleaner that produces a pressurized stream, or water jet, that moves the cleaning apparatus by reactive force or by driving a water turbine connected via a gear train to the wheels or endless track. The movement of the pool cleaners of the prior art, when powered by either the turbine or the direct or reactive jet is in one direction and the movement is random.

Control of the longitudinal directional movement of the robot can be accomplished by elaborate electronic circuitry, as is the case when stepper and D.C. brushless motors are employed. Other control systems require the cleaner to climb the vertical sidewall of the pool until a portion of the cleaner extends above the waterline and/or the unit has moved laterally along the sidewall, after which the motor drive reverses and the cleaner returns to the bottom surface of the pool along a different path. The water powered cleaners of the prior art also rely on the reorientation of the cleaner while on contact with the wall to effect a random change in direction. However, under certain circumstances; it is a waste of time, energy and produces unnecessary wear and tear to have the robotic cleaner climb the sidewall solely for purpose of changing the pattern of movement of the cleaner.

It is known from U.S. Pat. No. 2,988,762 to provide laterally offset fixed bumper elements at each end of the cleaner to contact the facing sidewall and provide a pivot point as the cleaner approaches the wall. Another transverse slide rod can

2

be provided to contact a side wall and causes the drive motor to reverse. The bumper elements are adjustable to provide variable angles. A third slide rod attached to a shut-off switch extends outboard of side facing the far end of the pool, so that when the cleaner has covered the entire length of the pool and approaches the wall is a generally parallel path, the third slide rod is pushed inboard and shuts off power to the unit.

It has also been proposed to direct the scanning movement of a pool cleaner mechanically by use of a three-wheeled array in which the third wheel is mounted centrally and opposite the other pair of wheels, and the axle upon which the third wheel is mounted is able to rotate in a horizontal plane around a vertical axis. A so-called free-wheeling version of this apparatus is shown on U.S. Pat. No. 3,979,788.

In U.S. Pat. No. 3,229,315, the third wheel is mounted in a plate and the plate is engaged by a gear mechanism that positively rotates the horizontal axle and determines the directional changes in the orientation of the third wheel.

It is also known in the prior art to provide a pool cleaner with a vertical plunger or piston that can be moved by a hydraulic force into contact with the bottom of the pool to cause the cleaner to pivot and change direction. The timing must be controlled by a pre-programmed integrated circuit ("IC") device.

It is also known from U.S. Pat. No. 4,348,192 to equip the feed water hose of a circular floating pool cleaning device with a continuous discharge water jet nozzle that randomly reorients itself to a reversing direction when the forward movement of the floating cleaner is impeded. In addition to the movable water jet discharge nozzle attached to the underside of the floating cleaner, the hose is equipped with a plurality of rearwardly-facing jet nozzles that move the water hose in a random pattern and facilitate movement of the cleaner.

Commercial pool cleaners of the prior art that employ pressurized water to effect random movement have also been equipped with so-called "back-up" valves that periodically interrupt and divert the flow of water to the cleaner and discharge it through a valve that has jets facing upstream, thereby creating a reactive force to move the hose and, perhaps, the attached cleaner in a generally backward direction. The back-up valve can be actuated by the flow of water through a fitting attached to the hose. The movement resulting from the activation of the back-up valve jets is also random and may have no effect on reorienting a cleaner that has become immobilized.

The apparatus of the prior art for use in propelling and directing the scanning movement of automated robotic pool cleaners is lacking in several important aspects. For example, the present state-of-the-art machines employ pre-programmed, integrated circuit ("IC") devices that provide a specific predetermined scanning pattern. The design and production of these IC devices is relatively expensive and the scanning patterns produced have been found to be ineffective in pools having irregular configurations and/or obstructions built into their bottoms or sidewalls.

Cleaners propelled by a water jet discharge move only in a generally forward direct, and their movement is random, such randomness being accentuated by equipping the unit with a flexible hose or tail that whips about erratically to alter the direction of the cleaner.

Cleaners equipped with gear trains for driving wheels or endless tracks represent an additional expense in the design, manufacture and assembly of numerous small, precision-fit parts; the owner or operator of the apparatus will also incur the time and expense of maintaining and securing replacement parts due to wear and tear during the life of the machine.

US 8,273,183 B2

3

A cleaning apparatus constructed with a pivotable third wheel that operates in a random fashion or in accordance with a program has the same drawbacks associated with the production, assembly and maintenance of numerous small moving parts.

The robotic pool cleaners of the prior art are also lacking in mechanical control means for the on-site adjustment of the scanning patterns of the apparatus with respect to the specific configuration of the pool being cleaned.

Another significant deficiency in the design and operation of the pool cleaners of the prior art is their tendency to become immobilized, e.g., in sharp corners, on steps, or even in the skimmer intake openings at the surface of the pool.

It is therefore a principal object of this invention to provide an improved automated or robotic pool and tank cleaning apparatus that incorporates a reliable mechanism and method of providing propulsion using a directional water jet for moving the cleaner in opposite directions along, or with respect to, the longitudinal axis of the apparatus.

It is another object of this invention to provide a method and apparatus for adjustably varying the direction of, and the amount of thrust or force produced by a water jet employed to propel a pool or tank cleaning apparatus, and to effect change in direction by interrupting the flow of water.

It is another important object of the invention to provide a simple and reliable apparatus and method for adjustably controlling the direction of discharge of a propelling water jet that can be utilized by home owners and pool maintenance personnel at the pool site to attain proper scanning patterns in order to clean the entire submerged bottom and side wall surfaces of the pool, regardless of the configuration of the pool and the presence of apparent obstacles.

A further object of the invention is to provide an improved apparatus and method for varying the position of one or more of the wheels or other support means of the cleaner in order to vary the directional movement and scanning patterns of the apparatus with respect to the bottom surface of the pool or tank being cleaned.

It is another object of the invention to provide a novel method and apparatus for periodically changing the direction of movement of a pool cleaner by intermittently establishing at least one fixed pivot point and axis of rotation with respect to the longitudinal axis of the cleaner for at least one pair of supporting wheels

Another object of the present invention is to provide a method and apparatus for assuring the free and unimpaired movement of the pool cleaner in its prescribed or random scanning of the surfaces to be cleaned without interference from the electrical power cord that is attached to the cleaner housing and floats on the surface of the pool.

Yet another object of the invention is to free a pool cleaner that has been immobilized by an obstacle so that it can resume its predetermined scanning pattern.

It is also an object to provide magnetic and infrared ("IR") sensing means for controlling the power circuits for the propulsion means of the cleaner.

Another important object of the invention is to provide an economical and reliable pool cleaner with a minimum number of moving parts and no internal pump and electric motor that can be powered by the discharge stream from the pool filter system or an external booster pump and which can reverse its direction.

Another important object of this invention is to provide an apparatus and method that meets the above objectives in a

4

more cost-effective, reliable and simplified manner than is available through the practices and teachings of the prior art.

#### SUMMARY OF THE INVENTION

The above objects are met by the embodiments of the apparatus and methods described below. In the description that follows, it will be understood that cleaner moves on supporting wheels, rollers or tracks that are aligned with the longitudinal axis of the cleaner body when it moves in a straight line. References to the front or forward end of the cleaner will be relative to its then-direction of movement.

In a first preferred embodiment, a directionally controlled water jet is the means that causes the translational movement of the robotic cleaner across the surface to be cleaned. In a preferred embodiment, the water is drawn from beneath the apparatus and passed through at least one filter medium to remove debris and is forced by a pump through a directional discharge conduit whose axis is aligned with the longitudinal axis of the pool cleaner. The resulting or reactive force of the discharged water jet propels the cleaner in the opposite direction. The water jet can be diverted by various means and/or divided into two or more streams that produce resultant force vectors that also affect the position and direction of movement of the cleaner.

In one preferred embodiment, a diverter or deflector means, such as a flap valve assembly, is interposed between the pump outlet and the discharge conduit, which diverter means controls the direction of movement of the water through one or the other of the opposing ends of the discharge conduit. The positioning of the diverter means, and therefore the direction of travel of the cleaner, can be changed when the unit reaches a sidewall of the pool or after the cleaner has ascended a vertical sidewall. The movement of the diverter means can be in response to application of a mechanical force, such as a lever or slide bar that is caused to move when it contacts a vertical wall, and through a directly applied force or by way of a linkage repositions the diverter means and changes the direction of the discharged, water jet to propel the cleaner away from the wall. In one preferred embodiment, power to the pump motor is interrupted and the position of the diverter means is changed in response to the change in hydrodynamic forces acting on the flap valve assembly. Mechanical biasing and locking means are also provided to assure the proper repositioning and seating of the flap valve.

The orientation of the discharged water jet can be varied to provide a downward component or force vector, lateral components, or a combination of such components or force vectors to complement the translational force.

In its broadest construction, the invention comprehends a method of propelling a pool or tank cleaner by means of a water jet that is discharged in at least a first and second direction that result in movement in opposite translational directions. The direction of the water jet is controlled by the predetermined orientation of a discharge conduit that is either stationary or movable with respect to the body of the cleaner. The discharge conduit can be fixed and the pressurized water controlled by one or more valves that operate in one or more conduits to pass the water for discharge in alternating directions. The discharge conduit can also comprise an element of a rotating turret that is preferably mounted on the top wall of the cleaner housing and is caused to rotate between at least two alternating opposed positions in order to propel the cleaner in a first and then a second generally opposite direction. The means for rotating the turret and discharge conduit can include spring biasing means, a motor or water turbine driven gear train, etc. During the change from one position to

US 8,273,183 B2

5

the alternate opposing position, the cleaner is stabilized by interrupting the flow of water from the discharge conduit, as by interrupting the power to the pump motor or discharging water from one or more other orifices. The invention comprehends methods and apparatus for controlling the movement of robotic tank and swimming pool cleaners that can be characterized as systematic scanning patterns, scalloped or curvilinear patterns and controlled random motions with respect to the bottom surface of the pool or tank. For the purposes of this description, references to the front and rear of the cleaning apparatus or its housing will be with respect to the direction of its movement. A conventional pool cleaner comprises a base plate on which are mounted a pump, at least one motor for driving the pump and optionally a second motor for propelling the apparatus via wheels or endless track belts; a housing having a top and depending sidewalls that encloses the pump and motor(s) is secured to the base plate; one or more types of filter media are positioned internally and/or externally with respect to the housing; and a separate external handle is optionally secured to the housing. Power is supplied by floating electrical cables attached to an external source, such as a transformer or a battery contained in a floating housing at the surface of the pool; pressurized water can also be provided via a hose for water turbine-powered cleaners. The invention also has application to tank and pool cleaners which operate in conjunction with a remote pump and/or filter system which is located outside of the pool and in fluid communication with the cleaner via a hose.

While the illustrative figures which accompany this application, and to which reference is made herein, schematically illustrate various embodiments of the invention on robotic cleaners equipped with wheels, it will be understood by one of ordinary skill in the art that the invention is equally applicable to cleaners which move on endless tracks or belts. Specific examples are also provided where the cleaner is equipped with power-driven transverse cylindrical rollers that extend across the width of the cleaner body.

In one embodiment of this aspect of the invention, an otherwise conventional cleaner is provided with at least one wheel or track that projects beyond the periphery of the apparatus in a direction of movement of the apparatus. In operation, this offset projecting wheel will contact the wall to stop the forward movement of the apparatus on one side thereby causing the cleaner to pivot until the opposite side makes contact with the wall so that the longitudinal axis of the cleaner forms an angle "b" with the sidewall of the pool. When the cleaner moves in the reverse direction away from the wall, it will be traversing the bottom of the pool at an angle "b". An apparatus equipped with only one projecting wheel or supporting member at one corner location of the housing will assume a generally normal position to an opposite parallel sidewall.

In a further preferred embodiment, a cleaner provided with a second projecting wheel or supporting member at the opposite end will undergo a pivoting motion as the cleaner approaches a wall in either direction of movement. The angle "b" can be varied or adjusted by changing the distance the wheel projects beyond the periphery of the cleaner. As will be appreciated by one of ordinary skill in the art, the angle "b" will determine the cleaning pattern, which pattern in turn will relate to the size and shape of the pool, the degree of overlap on consecutive passes along the surface to be cleaned, and other customary parameters.

In order to change the direction of movement when the cleaner assumes a path that is generally parallel to an end wall of the pool, the cleaner is provided with at least one side projecting member that extends outwardly from the cleaner

6

housing from a position that can range from at or adjacent the forward end to midway between the drive wheels or ends of the cleaner. The side projecting member acts as a pivot point when contacting a sidewall of the pool so that the cleaner assumes an arcuate path until it engages the contact wall. When the unit reverses, the new cleaning pattern is initially at approximately a right angle to the former scanning pattern. In another embodiment of the invention, a pair of the wheels located at one or both ends of the cleaner are mounted for rotation at an angle that is not at 90 degrees or normal to the longitudinal axis of the cleaner. Where the pairs of front and rear wheels are each mounted on a single transverse axle, one or both of the axles is mounted at an angle that is offset from the longitudinal normal by an angle "b". In another preferred embodiment, one side of the axle is mounted in a slot that permits movement to either the front or rear, or to both front and rear, in response to movement of the apparatus in the opposite direction.

In yet another embodiment, at least one wheel of a diameter smaller than the other wheels is mounted on an axle to induce the apparatus to follow a curved path. In another embodiment, the apparatus is provided with at least one pair of caster or swivel-mounted wheels, the axes of which independently pivot in response to changes in direction so that the apparatus follows a curved path in one or both directions. In this embodiment, providing the apparatus with two pairs of caster-mounted wheels will produce a scalloped or accentuated curvilinear motion as the unit moves from one point of engagement with the vertical sidewalls to another.

In a further preferred embodiment of the slot-mounted axle, one or more position pins are provided to fix and/or change the range of movement of the axle in the slot. These adjustments allow the operator to customize the pattern based upon the size and/or configuration of the specific pool being cleaned.

Another embodiment of the invention improves the ability of the cleaner to follow a particular pattern of scanning without interference or immobilization by providing an improved connector for the power cable. A swivel or rotating electrical connector is provided between the cleaner and the external power cord in order to reduce or eliminate interference with the scanning pattern caused by twisting and coiling of the power cord as the cleaner changes direction. The swivel connector can have two or more conductors and be formed in a right-angle or straight configuration, and is provided with a water-tight seal and releasable locking means to retain the two ends rotatably joined against the forces applied during operation of the cleaner.

In another embodiment of the invention, control means are provided to periodically reverse the propelling means to assure that the cleaner does not become immobilized, e.g., by an obstacle in the pool. If the pool cleaner does not change its orientation with respect to the bottom or sidewall as indicated by a signal from the mercury switch indicating that such transition has occurred during the prescribed period, e.g., three minutes, the control circuit will automatically change the direction of the drive means in order to permit the cleaner to move away from the obstacle and resume its scanning pattern. In a preferred embodiment of the invention, the predetermined delay period between auto-reversal sequences is adjustable by the user in the event that a greater or lesser delay cycle time is desired. Sensors, such as magnetic and infrared responsive devices are provided to change the direction of movement in response to prescribed conditions.

#### BRIEF DESCRIPTION OF THE DRAWINGS

The above objects and other advantages and benefits of the invention will be apparent from the following description in which:



US 8,273,183 B2

7

FIG. 1 is a side elevation, partly in cross-section, of a pool cleaner illustrating one embodiment of the directional water jet of the invention;

FIG. 1A is a side elevation, partly in cross-section of another embodiment of the invention of FIG. 1;

FIG. 1B is a side elevation, partly in cross-section, of a water jet valve assembly schematically illustrating another embodiment of the invention of FIG. 1;

FIGS. 2 and 3 are side elevation views, partly in cross-section, schematically illustrating the operation of the water jet valve assembly shown in FIG. 1;

FIGS. 4 and 5 are side elevation views of the embodiments of the valve assembly of FIGS. 2 and 3 provided with additional vertical discharge valves of the invention;

FIG. 6 is a top plan view of a flap valve member suitable for use with the embodiment of FIG. 1;

FIG. 7 is a top plan view of a flap valve assembly locking bar;

FIG. 8 is a side elevation, partly in cross-section, of the valve assembly of the invention installed on a pump;

FIG. 9 is a side elevation of the embodiment of FIG. 8, schematically illustrated in relation to a pool cleaner, shown in phantom;

FIG. 10 is a side elevation of another embodiment of the water jet valve assembly of the invention schematically illustrated in relation to a cleaner, shown in phantom;

FIG. 11 is a side elevation of another embodiment of the water jet valve assembly of the invention schematically illustrated in relation to a cleaner, shown in phantom;

FIG. 12 is a side elevation of another embodiment of the water jet valve assembly of the invention with pressurized water supplied by an external source, schematically illustrated in relation to a cleaner, shown in phantom;

FIG. 12A is a side elevation view, partly in cross-section, of a modified discharge conduit attachment in accordance with the invention;

FIG. 13 is a side elevation, partly in cross-section, of a pool cleaner equipped with the water jet valve assembly of the invention and external pressurized water source with venturi discharge openings;

FIG. 14 schematically illustrated an embodiment similar to that of FIG. 13 in which the filter system is externally mounted;

FIGS. 15-17 are side elevation views of a cleaner provided with auxiliary support means in accordance with the invention to improve the movement over obstacles and irregular surfaces;

FIG. 18 is a top plan view of a tandem cleaner provided with two water jet valve assemblies of the invention;

FIG. 19 is a side elevation of a prior art pool cleaner, partly cut away to show a fluid activated plunger assembly;

FIGS. 20-22 are side elevation views of pool cleaners, partly cut away, to show laterally mounted directional pivot assemblies of the invention;

FIG. 23 is a top and side perspective view of a portion of a pool cleaner to show a discharge conduit provided with an adjustable diverter for varying the directional discharge of the water jet form the valve assembly;

FIG. 24 is a top cross-sectional plan view of the diverter mechanism of FIG. 23;

FIG. 25 is a top plan view of a cleaner illustrating one embodiment of offsetting the discharge conduits to produce a non-linear movement of the cleaner in both directions;

FIG. 26 is a top plan view of a cleaner provided with means to create an uneven hydrodynamic drag force on side of the cleaner to produce a non-linear movement of the cleaner in one direction.

8

FIG. 27 is a side perspective view, partly in cross-section of an in-line electrical connector of the invention shown in relation to a segment of the cleaner housing;

FIG. 28 is a side elevation view, partly in cross-section, of an angular electrical swivel connector of the invention;

FIG. 29 is a plan view, partly in cross-section, of another embodiment of an in-line swivel electrical connector;

FIG. 30 is a prospective view of the assembled in-line swivel connector of FIG. 29 schematically illustrating its relation to the cleaner;

FIGS. 31A and 32A are top plan views schematically illustrating the prior art construction of a pool cleaner with pivot members extending from the front, and from the front and rear, respectively, in the direction of movement of the cleaner;

FIGS. 31B and 32B are schematic representations of the pattern of movement of the prior art pool cleaners of FIGS. 31A and 32A, respectively;

FIGS. 33 and 34 are top plan views schematically illustrating embodiments of the invention in which the cleaner's supporting wheels extend beyond the periphery to the front and to the front and rear, respectively to provide a pivot point;

FIGS. 35A and 35B are schematic illustrations of the patterns created by the embodiments of FIGS. 35 and 36;

FIGS. 35-44 are top plan views schematically illustrating embodiments of the invention in which the cleaner's supporting wheels are mounted on one or more axles that are offset at an angle to line that is normal to the longitudinal axis of the cleaner;

FIG. 45 is a side elevation view of an adjustable axle and wheel assembly similar to the embodiments illustrated in FIGS. 43 and 44;

FIG. 46 is a plan view of a curvilinear or free-form pool or tank schematically illustrating the predetermined scanning pattern in accordance with one embodiment of the invention;

FIG. 47 is a bottom plan view of one end of a pool cleaner wheel and axle assembly illustrating a mechanism for automatically changing the orientation of the wheels in response to a lateral contact with the side wall of a pool;

FIG. 48A is a sectional view of the wheel and mechanism taken along line AA of FIG. 47;

FIG. 48B is a sectional view of the opposite wheel and mechanism taken along line B-B of FIG. 47;

FIG. 49 is a sectional view taken along a line 49-49 of FIG. 47;

FIG. 50 is a top plan view of a cleaner equipped with motor-driven supporting rollers on a moving axle in accordance with the invention;

FIG. 51 is a top plan view having supporting rollers and a sliding axle in accordance with the invention that includes a universal joint; and

FIG. 52 is a flow chart illustrating a method of the invention for reversing the direction of movement of a cleaner in accordance with a prescribed program.

#### DESCRIPTION OF THE PREFERRED EMBODIMENTS

In the description that follows, a pool cleaner 10 has an exterior cover or housing 12 with a top wall 16, an internal pump and drive motor 60 that draws water and debris through openings in a base plate that are entrained by a filter 61.

The series of FIGS. 1-14 illustrate embodiments in which a single motor is used to vacuum debris and propel a swimming pool cleaning robot in combination with mechanically simple directional control means. In this embodiment, a temporary interruption of power to the motor will result in the reversal of the robot's movement. The interruption of power

US 8,273,183 B2

9

to the motor can result from a programmable power control circuit or be initiated by physical conditions affecting the cleaner.

FIG. 1 schematically illustrates, in partial cross-section, a pool cleaner 10 having a water jet valve assembly 40 forming a pump outlet that is mounted on top of a motor-driven water pump 60 and using impeller 58 to drive water "W" up through housing aperture 17 and into the valve assembly. The valve assembly 40 comprises a generally T-shaped valve housing 42 with depending leg 43 having a first end that is secured to cleaner housing flange 18, and a second end that is in fluid communication with discharge conduits 44R and 44L. Positioned in the interior of valve housing 42 is flap valve member, or diverter, 46 (shown in a transitory position). Referring now to FIGS. 6 and 7, flap 46 is illustratively provided with mounting posts 47, and two "T"-shaped spring-loaded lock bars 48R and 48L (also referred to generally as "lock bar(s)" 48) pivotally mounted on pivot posts 49 on either side of the flap 46. Lock springs 50 urge lock bars 48 into contact with flap member 46. The cross-section of the conduits 44L and 44R (also referred to generally as conduit(s) 44) can be round, rectilinear, or of any other convenient shape, the rectangular configuration illustrated being preferred.

FIG. 2 illustrates the sequence of movements inside valve housing 42. When power to the pump motor 60 is turned on, the water being pumped through jet valve housing 42 is a pressurized water stream W, which enters the housing and acts on the flap member 46 to urge it into a first position to close discharge conduit 44L at the left side of the valve. The pressurized water stream W also applies a force that urges the lock bar 48R to fold away from the valve member 46 in the right discharge conduit 44R, resulting in a water jet propulsion force that is emitted from the right end of discharge conduit 44R.

FIG. 3 illustrates the next sequence of steps or movements that result when power to the motor 60 is shut off and/or the flow of water W is interrupted. The sudden interruption of the water W flowing into the valve housing 42 causes the exiting water stream to create a low pressure or partial vacuum in the pump outlet, thereby causing flap member 46 to swing to the transitory (i.e., second) position over the pump outlet and towards the right discharge conduit. This movement of the flap member is followed by the movement of left lock bar 48L to lock the valve member 46 into position to the right of center. When power to the motor is turned back on, a second high pressure water stream is formed within the pump outlet that moves the diverter to a third position to close the right discharge conduit 44R, and the water flow will be directed into left discharge conduit 44L. It is possible to operate the jet valve assembly 40 without lock bars 48L and 48R; however, precise timing is required to turn the power on and to reactivate the pump 60 before valve member 46 swings back to its previous position prior to the interruption of the water flow.

FIG. 4 illustrates a further preferred embodiment in which provision is made for a reduction of excessive water jet pressure through the open end 45 of conduits 44R and 44L. To control and adjust the water pressure, openings are provided at both sides of flap valve 46, and adjustable closures, which can be e.g., sliding 53R, 53L doors proximate the openings provide for the desired amount of by-pass water the force of which, when directed upward, urges the robot 10 against the surface of the pool.

FIG. 5 illustrates an automatic mechanism to accomplish the above in which spring-loaded doors 54R, 54L open when the initial operating pressure is too high to maintain proper speed of robot, e.g., when the filter bag is clean. Doors 54 are mounted by hinged members 55 and biased into a closed

10

position by springs 56. As filter 61 accumulates debris and dirt, the bag clogs up, pressure drops and the spring-loaded doors close partially or completely.

FIG. 6 illustrates the configuration of a preferred embodiment of the flap valve member 46 and FIG. 7 shows one embodiment of a lock bar 48 of FIG. 1 (i.e., lock bars 48L or 48R, and the relation of associated lock spring 50. Other forms of biased mechanisms, including electronic and electromechanical means can be employed.

In another preferred embodiment of the invention, the flap 46 is moved by positive mechanical means in response to a contact with a side wall or other structure in the pool. For example, FIG. 1A illustrate a cleaner 10, similar in construction to that of FIG. 1, on which is mounted valve assembly 40'. Valve actuating member 240, is slidably mounted internally and parallel to the axis of the discharge conduits 44L and 44R in spiders 250 and passes through a slotted opening 248 in flap member 46'. Contact members 244 and 246 are mounted on rod member 240 on either side of flap member 46' and positioned to urge the valve into one or the other of its sealing positions to divert the water flow W. In operation, as the cleaner 10 approaches the sidewall, resilient tip member 242 contacts the wall and rod 240 is moved to the left in FIG. 1A until contact member 244 reaches flap 46' and moves it to the right. When the left-hand wheel 30 reaches the wall, the movement of rod 240 ceases and flap 46' is seated. With water W exiting discharge conduit 44L, the cleaner moves away from the wall with actuating rod 240 extending beyond the periphery of the cleaner and positioned to contact the opposite wall, where the process is repeated.

In another preferred embodiment, the flap 46 is moved by electro-mechanical means, e.g., a linear or circular solenoid. As schematically illustrated in FIG. 1B, a circular solenoid 260 having power cord 261 is mounted on the exterior of valve housing 42. The axially rotating element 262 of solenoid 260 engages flap 46. In one preferred embodiment, the IC controller for the cleaner sends a signal to activate the solenoid moving the flap 46 to its opposing position. It will be understood that the force of water stream W will seat flap 46 in the reversing position.

FIG. 8 illustrates the jet valve assembly as described in FIGS. 1-3 on which additional directional flow elbows 120R, 120L are secured to the terminal ends of the discharge conduits 44R, 44L. The assembly 40 can be produced with elbows 120 as an integral unit from molded plastic, cast aluminum or other appropriate materials.

The water jet discharged from the elbow 120 at an angle "a" to the translational plane of movement of the cleaner 10 produces a force vector component in a downward direction towards the wheels 30 as well as a translational force vector tending to move the cleaner across the surface being cleaned.

FIG. 9 illustrates the especially preferred location and orientation of the jet valve assembly 40 of FIG. 8 in relation to robotic cleaner 10 (shown in phantom.) In this embodiment, the discharge conduits 44, through their associated elbows 120L and 120R (also referred to generally as "elbow(s)" 120), project through the sidewalls of housing 12. In a further preferred embodiment, the elbows and valve housing 42 are integrated into the molded housing 12 which is produced from an impact resistant polymer. With further reference to the arrow "VR" indicates the resultant vector force produced by the expelled jet stream, the angle "a" of which is critical to the proper movement of robot 10 while on or off the vertical or angled side wall of a pool. As shown in FIG. 9, the projected resultant vector "Vr" crosses the horizontal or translational plane between the axles 32, and preferably in closer proximity to the front axle, where the front axle is defined by

US 8,273,183 B2

11

the direction of robot's movement as the leading axle. Providing an angle that places the line of resultant vector "VR" between the axles assures the stable operation of the cleaner.

In addition to providing a more compact and damage resistant construction, incorporation of discharge valve 40 into housing 12 reduces the number of separate parts required for the practice of the invention, thereby reducing costs. In this regard, use of a source of pressurized water from external source as specifically illustrated in FIGS. 12-14 (and which can be applied to all of the other embodiments described) eliminates the pump and motor assembly 60 resulting in further cost and material savings, as well as a reduction in operating and maintenance expenses. Moreover, by incorporating the valve assembly 40 in the interior of housing 12, other elements conventionally attached to the exterior of cleaners of the prior art can continue to be used, e.g., floating handles that control the alignment of the unit on the sidewall at the water line of the pool.

FIG. 10 illustrates a jet valve assembly similar to that of FIGS. 1-3 that is mounted upside down in a robotic cleaner (shown in phantom). In this embodiment the motor operates two propellers, one located at either end of the drive shaft. The upper propeller 58A creates a downward force, which when coupled with the horizontal or translational jet force emitted from discharge conduit 44R or 44L produces a resultant vector R ( $V_R$ ) that can be set in the proper angle by selecting the appropriate size for the upper propeller. In this embodiment, directional elbows are not required to provide a downward hydrodynamic force vector to urge the apparatus into contact with the surface to be cleaned.

FIG. 11 illustrates a jet valve assembly 40 that is mounted in cleaner 10 in a horizontal position, permitting a low profile for the cleaner housing 12. In the embodiment shown, the housing 12 is supported by large diameter wheels 30 and the axles 32 are positioned above valve assembly 40. As a result of the low center of gravity of the unit the discharge of the propelling force of the water jet can be limited to the horizontal or translational direction. The large wheel diameter allows the unit to traverse uneven surfaces.

FIG. 12 illustrates a jet valve assembly 40 which is connected to an external pump (not shown) by a flexible hose 152 attached to housing adapter 150 and therefore requires no internal pump motor. The hose 152 is secured to the robotic cleaning apparatus by means of a housing adapter 150 forming a discharge outlet (e.g., a swiveling elbow joint) 154 to allow unimpeded movement of the robotic cleaner and to prevent twisting of the hose 152. The housing adapter 150 is tubular and includes the discharge outlet 154 for discharging a pressurized stream of water from the external pump into the jet valve assembly 40. The jet valve assembly 40 directs the pressurized stream of water through one of the opposing ends (i.e., openings) of the directional conduit 44 to propel the cleaner in a forward direction. The switching of jet valve is accomplished by a solenoid valve (not shown) installed in-line near the external pump. Cleaners using this external pump system do not have filter bags to collect debris. Rather, the jet outlet is deflected slightly downward toward the surface being cleaned by directional flow elbows 120R, 120L so that the water jet turbulence stirs up the debris from the bottom or submerged surface of the pool or tank; once buoyant, the debris is filtered by the pool's permanent internal filter system. Generally, outside filtering systems have multiple inlets to the pool, one of them usually is equipped with a fitting so that flexible hose 152 can be connected to it. Utilizing this embodiment of the invention, an outside filter system becomes much more efficient since it is able to filter not only floating debris from the water's surface, but also debris dis-

12

lodged from the bottom or submerged surface of the pool or tank. To assure the downward directed jet streams do not flip the cleaner, supplemental weight member 156 is added to the bottom of the apparatus to maintain an overall negative buoyancy. The weight member can be one or more batteries for providing power to cleaner 10 where the pump is powered by an internal motor, as in FIGS. 1-11.

FIG. 12A illustrates a bi-axial flow diverter 124 attached to discharge conduit 44 for use with the robot of FIG. 12. It is desirable for ease of handling not to add additional weight to the cleaner. Instead of adding weight 156 (as shown in FIG. 12), each opposing end or opening of the discharge conduit 44 in this embodiment is provided with flow diverted with at least two channels 126 and 128 shaped so that part of the emitted water is directed downward at a relatively shallow angle via the first channel 128, while the other portion of the stream is directed upwardly at greater angle to the translational plane via the second channel 126. The combined force of the two streams results in a vector R (see, e.g., vector  $V_R$  of FIG. 10) that urges the robot against the surface on which it is moving.

FIG. 13 illustrates a robot of construction similar to that of the cleaner of FIG. 12, where an external pump is used to provide a pressurized stream of water to the cleaner via the discharge outlet 154 of the housing adapter 150. Further, the jet valve assembly 40 with its flap assembly 46 (see FIGS. 1A and 1B) can be used to control the direction in which the pressurized stream of water flows through the conduit 44<sub>L</sub> or 44<sub>R</sub> to propel the cleaner. This embodiment is further equipped with a coarse filter medium 172 (shown in phantom) and means 176 to dislodge debris from the pool surface so that it can be drawn into the filter 172. The open ends of the discharge conduits 44 (i.e., individually shown as discharge conduits 44<sub>L</sub> and 44<sub>R</sub>) are each fitted with a first end of an expansion sleeve 190 that has an inside dimension (e.g., inner diameter) that is larger than the outside dimension(s) (e.g., outer diameter) of the discharge conduit 44. The opposing end of each expansion sleeve 190 forms a discharge opening 196 from which the discharged water jet is expelled to propel the cleaner. The gap 182 formed between the conduit 44 and sleeve 190 creates a path through which water is drawn by the venturi effect, which is created as a result of the sudden increase in volume of the flow path and corresponding pressure drop. This pressure drop creates a negative pressure inside the robot housing 12 so that the jet streams that converge under the surface 184 of the cleaner are able to lift debris and carry it through the intake port 186 and into contact with the robot's filter medium 172. The jet streams are tapped off the inlet side of valve assembly 40 by hoses 178 connected to a transverse manifold 180 at the front and back of the robot. The manifold 180 has multiple openings 175 that extend across the full width of the robot's housing so that the jet cleaning streams impinge on the entire surface to be cleaned.

FIG. 14 illustrates another embodiment of the invention in which the cleaning robot is operated by an external pump (not shown). As shown in the cross-sectional view, the cleaner is provided with two external coarse filter or collector bags 173 that are secured to the outlets of the venturi chambers 192. Outlet jets 194, fed by hoses 193, are positioned in the chambers 192. Water issuing from jets 194 creates a low pressure zone drawing up water and loose debris from beneath cleaner 10, the debris being retained by filter bag 173. The chambers are connected to the intake side of the jet valve housing 44.

FIG. 15 illustrates a robot that is equipped with a plurality of auxiliary wheel or rollers 30' along the bottom or sidewalls between the supporting wheels 30 at either end of the cleaner 10. The auxiliary wheels can be mounted for free rotation on

US 8,273,183 B2

13

the housing 12 or external side plate. This configuration prevents the robot from being immobilized on a hump or other vertical discontinuity in the bottom surface of the swimming pool or tank being cleaned.

FIG. 16 illustrates a robot similar to that of FIG. 15, but instead of wheels or rollers, the bottom edges of the robot's side walls 12 or side plates 15 facing the pool surface are provided with Teflon® or other low-friction engineering plastic strips 201 so that the apparatus slides along on the bottom edges.

FIG. 17 illustrates another embodiment of the robot that is equipped with "immobilization" means. These means comprise two idling wheels 204, 206 connected to each other by a belt 208. It should be noted that although the so-called "immobilization" devices generally are installed on opposing sidewalls of the robot, there are instances in which it is desirable to equip the robot only on one side. This will result in random turning of the robot in one direction or the other whenever it goes over a hump as shown in FIG. 15.

FIG. 18 illustrates a cleaning robot with two water jet valve assemblies to which are attached directional flow elbows 120. In addition, there are a plurality of pumps having outlets 220 to increase the vacuum effect and cleaning ability of the robot. The multiple jet valve system is especially suited for remote control operation, since each jet valve can be controlled independently. As illustrated, the robot is equipped with rollers 30; however, wheels can also be used with this embodiment.

#### Vertical Pivot Axis

FIG. 19 illustrates a conventional fixed spring-loaded cylinder assembly 330 of the prior art which is activated by hydraulic force supplied by a pump motor (not shown) via hose 342, the timing of which is controlled electronically, e.g., by a pre-programmed integrated circuit device 344. When the hydraulic force is applied, the piston 346 moves to engage the surface causing the cleaner to pivot about the axis of piston 346. Use of this device produces random motion by the cleaner.

FIG. 20 illustrates a robot that is equipped on one side only with a cylinder assembly 300 that is free to rotate longitudinally towards both ends of the cleaner. The assembly's upper end 302 is pivotally mounted at 304 on the side of the robot at a position that is transversely displaced from the central longitudinal axis of the apparatus. At the lower end of the cylinder 300, a spring-loaded piston 306 extends downwardly toward the bottom of the pool. Each time the robot reverses its direction, the cylinder assembly 300 applies a transitory frictional braking force to the motion of the robot on one side which results in a pivoting action about the vertical axis of the piston and the repositioning of the longitudinal axis of the apparatus. This braking action lasts until the piston 306 is pushed into the surrounding cylinder 308 far enough to allow the cylinder assembly to pivot past its vertical position. The rate at which the piston moves can be controlled, e.g., by an adjustable valve 310 at the top of the cylinder. In the practice of this embodiment of the invention, the robot can have wheels mounted on fixed axles in parallel relation and still be able to scan the bottom surface of a rectangular pool.

FIG. 21 illustrates a robot that is equipped with an arm 320 pivotally mounted on one side of the cleaner housing at a position similar to that of FIG. 20, but which engages the pool bottom when the cleaner moves in only one direction. The lower end of arm 320 is arcuate, e.g., shaped as a segment of a circle, the center of which coincides with the pivot point 324 of the arm. A cylinder assembly 322 similar to the one described in FIG. 20, but without the spring, is pivotally linked to the arm at 323. However, the piston 326 is free to move in one direction only; movement in the other direction

14

is controlled by an adjustable valve 310. When the robot changes direction, only every second time does the cylinder assembly apply a frictional braking force to halt the forward motion of the robot. Use of this apparatus and method of operation produces a scanning pattern for the cleaner that which consists of alternating perpendicular and angular paths with respect to the sides of a rectangular pool. In pools where the robot climbs the vertical side walls, the braking or pivot arm will continue to pivot while on the wall (due to gravity) as shown in phantom, so that when the robot comes off the wall, the arm will not immediately touch the bottom of the pool. In this mode of operation, a few seconds will pass before gravity pulls the arm 320 down to make contact with the bottom surface of the pool. The robot will move horizontally for a short distance before it changes direction by pivoting around the pivot arm.

FIG. 22 illustrates yet another embodiment in which pivot arm 330 extends in a downward direction to make contact with the bottom floor of the pool to provide a frictional braking force in both directions of movement and a pivot axis on one side of the robot 10. This mechanism works similarly to that of FIG. 20, and is relatively simpler and less expensive. A friction pad 334 is attached to adjustment means 332 which permits the frictional contact between the pad 334 and end of pivot arm 330 to be varied to thereby control the pivoting time that the opposite end of said arm is in contact with the pool surface and before disengagement of the pad and pivot arm. The friction pad can be a directional resistance material that is, greater resistance is provided in one direction than in the other.

As shown in FIG. 23, the open end of one or both of the outlets of the discharge conduit or directional flow elbow is provided with internal flow diverter means 550. Internal dove tail configuration 35 has an outwardly tapered throat and is provided with adjustable diverter flap 554 in the discharge flow path that directs the flow of water to one side or the other of the outlet 120. As more clearly shown in the cross-section view of FIG. 24, the dove tail outlet is provided with diverter flap positioning means 556, e.g., two set screws to adjust the position of the diverter flap 554. The cross-sectional area of the elbow when the diverter means is positioned at one side or the other is about the same as the area of the discharge conduit 120, i.e.; there is no restriction of the flow, or increased back pressure. By having the water jet exit angularly to the left or to the right of the longitudinal centerline, the robot will follow an arcuate path in one direction or the other. The radius of the arc can be controlled by the adjustable positioning of the diverter flap 554. The cleaning apparatus of this embodiment can also be set to operate in a more random manner by retracting the adjusting screws 556 to allow the diverter flap to pivot freely from left or right each time the water jet impacts it. A manually adjustable flap 554 enables the user to change its position from time to time in order to unwind a twisted power cord, should that occur.

FIG. 25 illustrates another method by which a scanning pattern is achieved without changing the position of the wheels or the axles. The jet valve assembly 40 is positioned off-center of the central longitudinal axis "L" of the cleaner 10 to thereby produce movement in a semi-circular or other curvilinear pattern.

FIG. 26 illustrates another embodiment in which a scanning movement is achieved by providing the exterior of the housing 12 with a configuration that presents an asymmetrical hydrodynamic resistance to movement through the water. In the specific embodiment illustrated, the unequal hydrodynamic resistance is effected by adding a resistance flap 360 to one side of an otherwise symmetrically designed robot hous-

US 8,273,183 B2

15

ing 12. The water resistance causes the robot to curve to the left or right. If the resistance means is pivotally mounted at 362 as shown, the robot moves straight in one direction and assumes a curved path in the other. A plurality of flap position members 364 are provided for adjusting the stop position of pivoting flap 360 to thereby vary the resistance. The asymmetrical hydrodynamic resistance can also be achieved by integrally molding the housing on one or both ends so that it presents unequal hydrodynamic resistance during movement.

#### Power Cord Swivel Connector

In order to reduce or eliminate interference with the scanning pattern of the cleaner associated with twisting and coiling of the floating power cord 70 as the cleaner repeatedly changes direction which results in the tethering of the cleaner, another embodiment of the invention comprehends a swivel or rotatable connection at a position along the power cord, or between the power cord and the moving cleaner.

With reference to FIG. 27, there is schematically illustrated a cross-sectional view of the upper surface 16 of housing 12 provided with an aperture 78 adapted to accommodate socket portion 82 of electrical swivel connector socket 80. Socket 82 is fabricated from dielectric material 83 and is provided with electrical contacts 86a and 88a which in turn are joined to female plug 90 by conductive wires 89. Plug 90 is adapted to mate with male plug 92 which terminates electrical wire 93 from the motor (not shown.)

With further reference to socket 82, a groove 94 is provided proximate the open end to receive an o-ring 96 or other means for sealing the socket and locking the plug or jack portion 84 into secure mating relation. Jack 84 is comprised of insert member 98 fabricated from dielectric material, and electrical contacts 86b and 88b that are adapted to be received in sliding contact with corresponding elements 86a and 88a in socket 82. Insert member 98 is also provided with a groove or annular recess 99 that is adapted to engage ring 96 in fluid-tight sealing and locking relationship when jack 84 engages socket 82. It will also be understood that different or additional means can be provided to secure the mating sections 82 and 84 together that will also permit them to rotate when mated. Insert member 98 is secured in water-tight relation to right angle member 100, preferably fabricated from a resilient dielectrical material, through which are passed a pair of electrically conductive wires (not shown) from power cord 70 that terminate, respectively, at conductors 86b and 86b. Right-angle jack member 100 is also constructed with a plurality of flexure members 102 about its periphery in order to provide additional flexibility between the housing connection and the power cord 70 during operation of the cleaner. It will be understood that the right-angle jack member 100 will freely swivel in the opening of socket member 82 in response to a force applied by power cord 70. Thus, the power cord 70 remains free of coils, does not suffer any effective shortening in its length and therefore does not exert any tethering restraining forces on the cleaner that would adversely effect the ability of the cleaning apparatus to freely traverse its path.

With reference to FIG. 28 there is shown a second embodiment of an electrical swivel connector for joining the power cord 70 to the motor electrical wire 93 via elements as described above in connection with FIG. 27. In the embodiment illustrated, a straight-line swivel is comprised of socket member 82' and plug member 85, the former being joined by a short length of power cord 91 extending through restraining gasket 79 secured in opening 78' in a sidewall of cleaner housing 12. The two sections of the swivel connector are securely joined together in rotating relationship as described above with reference to FIG. 27. As the cleaning apparatus moves about the pool surfaces, the socket 80 moves in

16

response to the tension transmitted through power cord 70 and any twisting or torsional forces are dissipated by the rotation of plug 85 in socket member 82. The power cord therefore does not form coils, or otherwise have its effective length reduced, and does not stop adversely effect the movement of the cleaned.

In another preferred embodiment of the swivel connector, a permanent in line or straight connection between two sections of power cable 70 is provided by a connector permitting angular displacement between its elements. As illustrated in FIG. 29, connector 104 comprises a rigid non-corroding ferrule 105, which can be in the form of a length of polymeric or stainless steel tubing that extends between waterproof tubular junction members 106, 106' that also receive opposing cable ends 70. One of the junction members 106 contains electrical connector jack 107 and plug 108 which are axially rotatable with respect to each other. A conductor pair 109 of cable 70 are permanently joined to the adjacent terminals of jack 107 and secured in place within junction member 106, e.g., by a plug of flowable epoxy resin 110 or other potting material that hardens after the elements have been assembled.

With further reference to FIG. 29, a pair of conductors 111 extending from the rear of plug 108 extend axially through ferrule 105 and a bushing 112 is placed on ferrule 105 to engage the rear shoulder of jack 108. In a preferred embodiment, the ferrule end is flared and the adjacent surface of annular bushing 112 is shaped to receive the ferrule. The junction member containing the connector jack and plug is completed by securing on tubular member 106, cap 113 having a central orifice into which is secured axial seal 114 which passes over ferrule 105 and permits rotation of the ferrule in water-tight relation. The assembly of the adjoining junction member 106' is completed by joining conductor pair 111 to the conductor pair 109 of cable 70 and filling the end with flowable epoxy resin 110 and installing cap 113'. When the epoxy or other potting compound has set, it will be understood that the two ends of cable 70 are permanently joined and that ferrule 105 has been secured to junction member 106' in water-tight relation and that plug 108 is free to rotate with respect to jack 107 and the assembly of junction member 106. In this embodiment, the swiveling or rotatable connector assembly 104 is positioned approximately three meters from the cleaner to reduce the likelihood that the user will lift the cleaner from the pool using a section of the power cable that includes the connector.

As schematically illustrated in FIG. 30, any twisting or torsional forces transmitted by the movement of the cleaner 10 through the attached length of power cord 70 will be dissipated by the rotation of member 106.

It will also be understood by one of ordinary skill in the art that various other mechanical constructions can be provided that will permit relative rotation between adjacent sections of the power cable, one end of which is attached to the cleaner and the other to the external fixed power supply to thereby eliminate the known problems of cable twisting, coiling and tethering that adversely effect the desired scanning patterns or random motion of the pool cleaner.

#### Axle Orientation

By way of background, the series of FIGS. 31A and 32A are representative of the prior art. FIGS. 33-44 schematically illustrate in plan view the apparatus and methods embodying the invention to control the movement of a swimming pool cleaning robots 10 to produce systematic scanning patterns and scalloped or curvilinear patterns, and to provide controlled random movement on the bottom surface of pool. The configurations will provide one or more of the above three

US 8,273,183 B2

17

mentioned movements. The cleaner can be propelled either mechanically or by a discharged jet or stream of water.

In the prior art arrangement shown in FIG. 31A, an offset extension member 400 is secured to one end of housing 12 at a position that is displaced laterally from the longitudinal axis "L" of the cleaner and which causes the robot to position itself angularly in relation to vertical swimming pool wall 401 (shown in phantom.) When the robot 10 reverses its direction, it travels at an angle "b" away from the side wall 401. When cleaner 10 contacts the opposite side wall 403, the robot's body again pivots and comes to rest in a position where its longitudinal axis "L" is at a 90 degree angle to side wall 403. The resulting scanning pattern is illustrated in FIG. 31B.

In the prior art configuration of FIG. 32A, a second offset extension member 402 is added to the housing opposite extension member 400. The scanning pattern provided by two opposing extension members is generally shown in FIG. 32B. The 90 degree pivoting turns occur in both a clockwise and counter-clockwise direction.

In accordance with the improved method and apparatus of the invention, separate members projecting from the front and rear housing surfaces are eliminated, and in one preferred embodiment, at least one supporting wheel, or track, or roller end, projects beyond the periphery of the cleaner in the direction of movement to contact a vertical side wall or other pool surface.

In the preferred embodiment of FIG. 33, one of the wheels 30a is mounted so that it projects forward of the housing 12 as a pivot point and thereby causes the same angular alignment between the robot 10 and swimming pool wall 401, as the apparatus of FIG. 31, and produces a scanning similar to that of FIG. 31A. With further reference to FIG. 33 is a ball-shaped side extension 404 terminating in tip 406 formed of resilient, soft rubbery material which, when it comes in contact with the end wall of pool 405, 407, causes the robot to make a 90 degree pivoting turn, indicated turn by arrow in FIG. 31B. As the pattern shows, every time this 90 degree turn occurs the cleaner turns in a clockwise direction. It will be understood that if the side projection member 406 had been placed at the upper left side of the housing 12, the 90 degree turns would have been counter-clockwise.

In the embodiment of FIG. 34 two opposing wheels 30a, 30b at the left side of robot 10 are mounted forward of the periphery at their respective ends of the cleaner to provide a translational pivot axis. This configuration creates a scanning pattern similar to that shown in FIG. 32B. In this embodiment of FIGS. 31A to 34, the wheels are individually rotatable and their axles are stationary. With this embodiment, power cable twisting is not a problem.

With reference to the embodiment of FIG. 35, a pair of wheels 30c is mounted on caster axles pivoted for limited pivoting movement defining an arc in the translational plane passing through the center of the wheels. The axles and wheels 30c swivel so that when the robot moves in the direction opposite the caster mounts, all four wheels are parallel with each other along the longitudinal axis of the robot. When the robot moves in the opposite direction, i.e., the caster wheels lead, the caster wheel axles swivel or pivot to a predetermined angle, which angle can be adjustable. The robot scans a rectangular pool in a manner shown in FIG. 35A, where the path is curvilinear in one direction and straight in the other. The angular arc can be up to about 15 degrees from the normal, and are preferably adjustable to account for the pool dimensions.

In an embodiment related to that of FIG. 35 (but not shown), all four wheels are caster mounted, the opposing pairs being set for angular displacement when the cleaner

18

moves in opposite directions. That is, depending on the direction of the robot's movement, when one pair of wheels are at an angle to the robot's longitudinal axis the opposite set of wheels are parallel to the axis "L", and vice versa. The scanning pattern would be as illustrated in FIG. 35B.

In the embodiment of FIG. 36, the transverse axles 32 are mounted in an angular relation to each other so that the wheels on one side of the cleaner are closer together than those on the opposite side. The scanning pattern is as illustrated in FIG. 36B.

As shown in FIG. 37, one end of one of the axles is mounted in a slot so when the robot moves one direction it follows a curved path, and when it moves in the opposite direction (i.e.; where the slot is in the rear of the cleaner) the robot follows a straight line. (The pattern is shown in FIG. 35A).

In the embodiment of FIG. 38, the wheel axles are parallel to each other and normal to the longitudinal axis "L" of the robot, and the wheels 305 on one side of the cleaner are smaller in diameter than the wheels on the opposite side. The scanning pattern is as illustrated by FIG. 35B.

As shown in FIG. 39, all four wheels of the robot 10 are caster mounted, and all four wheels move together to be either parallel to the robot's axis, or at an angle to the axis "L", depending on the direction in which the robot moves. The scanning pattern is as shown in FIG. 31B. The angular displacement can be up to 45 degrees, since all four wheels are moving in parallel alignment.

In FIG. 40, the four wheels are mounted to swivel in unison, and move as in FIG. 39. When the wheels are rotated to their extreme (i.e., maximum) positions, they are angular to the robot's body, but symmetrical to each other. This arrangement provides a scanning pattern as shown in FIG. 32B. Again, the angular displacement of the caster wheels can be up to 45 degrees in both directions from the normal. It will be understood that the longitudinal axis of cleaner 10 will be perpendicular to the wall it contacts.

As also illustrated in FIG. 40, both longitudinal sides of the cleaner 10 are provided with at least one projecting member 404. As will be described in more detail below, the pivoting function of side-extending pivot contacts as represented by the specific embodiments of elements 404, can also be effectuated by elements projecting from the external hubs of two or more of wheels 30 (see e.g., FIG. 43), or the side wall surfaces of cover 12 (see, e.g., FIG. 18) or other side peripheral structure of the cleaner 10. The transverse projection of such elements is determined with reference to their longitudinal position and the shape or footprint of the peripheral projection of the cleaner on the pool surface. For example, a side-projecting frictional pivot member located at the leading edge of a generally rectilinear cleaner will require less projection than a single member of FIG. 33 that is located mid-way between the ends of the cleaner.

In FIG. 41, both axles are mounted in slots 320 on one side of the unit so that the wheels adjacent the slots can slide up and down to be either parallel to the robot's longitudinal axis, or at an angle thereto, depending on the direction of movement of the cleaner. This arrangement produces the scanning pattern of FIG. 31B.

In the embodiment of FIG. 42, the axles swivel in larger slots 320 to achieve angular positioning of wheels to the robot's body in both extreme positions, but in symmetrical fashion, with a resulting scanning pattern as shown in FIG. 32B.

From the above description, it will be understood that when operating in a rectangular pool or tank, the embodiments shown in FIGS. 39-42 allow the robot to move parallel to the swimming pool's end walls, even when it travels other than

US 8,273,183 B2

19

perpendicular to the sidewalls. In other words, the correct scanning pattern does not require an angular change in the alignment of the robot's body caused by a forceful contact with a swimming pool wall as with the prior art. This is particularly important where a water jet propulsion means is employed, because as the filter bag accumulates debris in the jet propulsion system, the force of the water jet weakens and the force of impact lessens, so that the robot's body may not be able to complete the pivoting action required to put it into the correct position before it reverses direction. This is especially true in Gunitite or other rough-surfaced pools in which a robot with even a clean filter bag may not be able to pivot into proper position because the resistance or frictional forces between the wheels and the bottom surface of pool may be too great to allow the necessary sideways sliding of the wheels before reversal of the propelling means occurs.

As shown in FIG. 43, one of the axles is mounted in slots 320 that permit it to move longitudinally at both ends. This longitudinal sliding motion is restricted by one or more repositionable guide pins 330. These pins allow the user to adjust the angular positioning of the axle to accommodate the width or other characteristics of the pool. By reversing the position of the pins on both left and right sides, the robot will follow a pattern which is similar to that shown in FIG. 35A. This method of operation will also unwind a twisted cable.

With further reference to FIG. 43, there are shown mounted on the ends of axles 32 or hubs of wheels 30 side projecting pivot member 200. These members serve the same function and can be constructed of materials as described with reference to side projecting members 404 as described in connection with FIG. 33, above. Pivot member 200 can be mounted on one or both sides of the cleaner 10 to engage the sidewall of the pool and cause the cleaner to pivot into that wall.

In FIG. 44, both axles are mounted in slots permitting longitudinal movement at both ends. This will allow the robot with proper positioning of the guide pins to advance in a relatively small circular pattern in one direction and in a slightly larger one in the other.

It is to be noted that the odd-numbered embodiments of FIGS. 31 to 44 illustrate devices which turn only one way when they make 90 degree pivoting turns, and that the embodiments of even-numbered FIGS. 2 to 14 turn both ways. Simply put, when the robot scans in an asymmetrical pattern, such as in FIGS. 1A, 3, 5, 7, 9, 11 and 13, it turns either clockwise or counter-clockwise; when the robot scans in a symmetrical pattern, such as in FIGS. 2, 4, 6, 8, 10, 12 and 14, it turns in both directions. The two main categories are in relation to their movements. Within these principal categories, there are variations where straight-line movements are replaced by curved paths, e.g., in FIG. 20, or the two are combined, e.g. in FIG. 18.

It is relatively easy to clean a rectangular pool in any systematic scanning manner as shown above, but it is more difficult to clean an irregularly-shaped pool. Applying the method and apparatus of the invention and using the guide pins set as described above, the robot can scallop a free form pool in a systematic manner as shown in FIG. 46.

FIG. 45 shows the six different arrangements in which each wheel 32 can be positioned. By pressing the appropriate pins 330 down or pulling them up, the wheel axle 30 can be placed in three stationary positions: outside, center and inside. It can also be placed in three sliding positions outside to inside; outside to center; and center to inside. Since there are four wheels, the total combination of positions of these wheels is 1296 (6 to the 4th power) which provides a total of 361 different scanning patterns.

20

In a particularly preferred embodiment employing a transverse axle 32 one-half inch in diameter, the axle supporting members 353 are provided with slots 320 extending 1.5 inches longitudinally to receive the axle in slidable relation. Each slot is provided with a central lock pin 330 which can optionally be withdrawn from the slot. This configuration provides a sufficiently large number of combinations and angular displacements of wheels and axles to cover essentially all of the sizes and shapes of pools in common use today. The flexibility of this embodiment gives the user the ability to select an optimum cleaning pattern for all types, sizes and shapes of pools.

The embodiment illustrated in FIG. 47 provides an apparatus and method that automatically switches the positions of two wheels when the scanning robot reaches the end of the pool. Unlike the embodiments described above that provided the robot with means by which to turn 90 degrees clockwise or counter-clockwise, this embodiment allows the robot to maintain its orientation in a rectangular pool that is parallel with the swimming pool's walls. Using this embodiment, the power cord cannot become twisted or formed into tight coils. Moreover, a coarse surface having a high coefficient of friction does not adversely effect desired scanning patterns. The robot has two side plates 350 which are provided with horizontal slots 352 to hold the ends of transverse axle 32. Pivotaly mounted at pivot pin 353 on the inner side of the side plates and overlapping the horizontal slots are two identical guide plates 354, 354' each of which is provided with an L-shaped slot 355 to freely accommodate movement of axle 32. Two levers 356, each of which is pivotally mounted at one of its ends concentrically with the pivot point of each of the guide plates. The other end of each lever 356 extends into a 45 degree slot 358 provided in slidably mounted in transverse cross-bar 360, which cross-bar extends beyond the periphery of a side wall of housing 12 a distance that is sufficient to contact on adjacent pool wall. Each of said guide plates 354 is linked with its corresponding lever 356 through a spring 362, said spring being secured to pins 364 protruding from said guide plates and levers.

With respect to FIG. 48A, which is a view taken along line 22-22 of FIG. 47, it can be seen that spring 362 is pulling guide plate 354 counter-clockwise holding the longer vertical leg of the upside down L-shaped slot in position for the wheel axle to slide freely.

With reference to FIG. 48B, which is a view taken along line 23-23 of FIG. 47, it can be seen that spring 362 pulls corresponding opposite guide plate 354' clockwise, locking that end of wheel axle 32 into a forward stationary position relative to the opposite end of the axle.

During operation, as the cleaner approaches a pool side wall that is generally parallel to the longitudinal axis of the cleaner, the projecting end 360R of the slidably mounted cross-bar comes in contact with the swimming pool wall, and the bar slides to the left, as indicated FIG. 49. This horizontal movement of bar 360 is translated into a vertical or lifting force on levers 356 via the 45 degree slots 358 in bar 360. This results in the flipping of levers 356 to their opposite side. This movement causes springs 362 to pull their respective guide plates 354, 354' to the opposite position, locking the right end of the axle 32, while freeing up the left end. While this action on the left end of axle 32 is instantaneous, the right end is not locked in position until the robot reverses direction, at which time the right end of axle 32 slides into a trap provided by the short leg of L-shaped slot 355 in guide plate 354. Using this apparatus, the cleaner 10 continues to travel back and forth between the same end walls of the pool but over a different

US 8,273,183 B2

21

reverse path that is determined by the angular displacement of the wheels and/or axles, thereby assuring cleaning of the entire surface.

FIG. 50 illustrates another embodiment of the invention in which pool cleaner 10 is provided with a plurality of rolling cylindrical members in place of wheels. The long cylinder 500 is driven at one end by a flexible chain belt 510 at presses around sprocket 512 attached to an electric motor or water turbine drive shaft (not shown.) A pair of shorter rollers 502, 504 is mounted on transverse axle 506. As schematically illustrated, the right end of axle 506 is free to move longitudinally in slot 508 provided in axle support member 520. The use of a drive chain and sprocket allows for changing alignment of supporting axle 506 and eliminates problems of tensioning and resistance to movement associated with timing belts used by the prior art. A cleaner constructed in accordance with this embodiment will exhibit a scanning pattern similar to that of FIG. 32B.

FIG. 51 schematically illustrates a robot 10, which uses a pair of drive belts or chains 510a, 510b to power two cylindrical members 500, 501. The right end of axle 506 is free to move in slot 510 provided in axle support member 520 and the opposite end of axle is provided with a universal joint 522 which in turn is attached to a driven pulley or sprocket 512. The scanning pattern of this unit is also similar to the one shown in FIG. 32B.

With further reference to FIGS. 50 and 51, there are shown side projecting pivot members 202 secured to the exterior of side supporting member 520. Similarly, pivot members 202 can be secured to the opposite side, e.g., on housing 12, or other outboard supporting member to provide a point of frictional engage with a sidewall of the pool to effect a pivoting turn of the cleaner into the wall where it is properly oriented for eventual movement away from the wall, e.g., upon reversing of the cleaner's water jet or other drive means.

It will be understood that in the apparatus of FIGS. 31-44 the wheels mounted on transverse axles can be replaced with cylindrical roller members of the types illustrated in FIGS. 50 and 51.

In determining the optimum angular displacement of the axles and caster mounted wheels, it will be understood that the length of the longitudinal slots provide a practical limitation on the angle of the axle, while the caster axles can provide a greater angular displacement for the wheels. The angular displacement of the coaster wheel axles can be up from 20 degrees to 45 degrees from the normal and are preferably up to 10 degrees, the most preferred being up to about 5 degrees from the zero, or normal line.

#### Auto-Reversal Sequence

One embodiment of the apparatus and method of the invention addresses problems associated with the immobilization of the cleaner. The electronic control means of the pool cleaner is programmed and provided with electrical circuits to receive a signal from at least one mercury switch of the type which opens and closes a circuit in response to the cleaner's movement from a generally horizontal position to a generally vertical position on the sidewall of the pool or tank. The use of mercury switches and a delay circuit to reverse the direction of the motor is well-known in the art. As will be understood by one of ordinary skill in the art, a pool cleaner can become immobilized by a projecting ladder or other structural feature in the pool so that its continuing progress or scanning to clean the remaining pool surfaces is interrupted. In accordance with the improvement of the invention, the electronic controller circuit for the motor is preprogrammed to reverse the direction of the motor automatically if no signal has been generated by the opening (or closing) of the mercury switch after a

22

prescribed period of time. A suitable period of time for the auto-reversal of the pump or drive motor is about three minutes.

This sequence of program steps is schematically illustrated in the flow chart of FIG. 52, where the time clock begins to count-down a prescribed time period after the cleaner is activated. In a preferred embodiment, the timer can be manually set to reflect the user's particular pool requirements. Alternatively, the time clock can be factory-set for a period of from about 1.5 to 3 minutes. If the mercury switch changes position the time clock stops its count-down and/or a delay circuit is activated to allow time for the cleaner to climb the sidewall of the pool, e.g., about 5-10 seconds. At the end of the delay period, the drive motor is stopped and/or reversed to move the cleaner down the wall. In the event the timer reaches the prescribed time period without receiving a signal from the mercury switch, a signal is transmitted to stop and/or reverse to drive motor. If the cleaner has been immobilized by an obstacle, this timed auto-reversing of the drive motor will move the cleaner away from the obstacle to resume its scanning or random motion cleaning pattern.

#### Power Shut-Off

The method and apparatus of the invention also comprehends the use of a power shut-off circuit that is responsive to a signal or force that corresponds to a magnetic field. In one preferred embodiment, a magnet or magnetic material is formed as, incorporated in, or attached to a movable element that forms part of the cleaner, e.g., a non-driven supporting wheel or an auxiliary wheel that is in contact with the pool surface on which the cleaner is moving. One suitable device is a reed switch that is maintained in a closed position (e.g., passing power to the pump motor) so long as the adjacent magnet is moving past at a specified rotational speed, or rpm. If the rotation of the magnet stops, as when the cleaner's advance is stopped by encountering a sidewall of the pool, the reed switch opens and the power to the drive motor is interrupted. In a preferred embodiment, the circuit includes a reversing function so that the cleaner resumes movement in the opposite direction and the reed switch is closed to complete the power circuit until the unit again stops, e.g., at the opposite wall.

In a further specific and preferred embodiment of the invention, the cleaner is provided with an impeller that is rotatable in response to movement through the water. One or more of the impeller blades and/or mounting shaft is provided with or formed from a magnetic material. A sensor is mounted proximate the path of the moving magnet and an associated circuit is responsive to the signal generated by the sensor due to the movement, or absence of movement, of the magnet. In one preferred embodiment, the magnetic sensor circuit is incorporated in the cleaner IC device that electronically controls the pump motor, so that when the cleaner's movement is halted by a vertical side wall, the movement of the impeller and associated magnetic material also ceases and the sensor sends a signal through the circuit to interrupt power to the pump motor. After a predetermined delay period, the pump motor can be reactivated, in either the same or the reverse direction, to cause the unit to move away from the wall. The same circuit can be employed to control a drive motor that propels the drive train for wheel, track or roller mounted cleaners.

In another embodiment, the cleaner is provided with an infrared ("IR") light device that includes an IR source and sensor and related control circuit that is responsive to a static position of the cleaner adjacent a side wall of the pool or tank.



US 8,273,183 B2

23

When the returned IR light indicates a static position the circuit transmits a signal that results in the reverse movement of the cleaner.

In a further preferred embodiment, the electric or electronic controller circuit of the cleaner includes an "air sensor" switch that sends a signal or otherwise directly or indirectly interrupts the flow of water stream W when the sensor emerges from the water. In one preferred embodiment the sensor is a pair of float switches, one located at either end of the cleaner. When the cleaner climbs the vertical sidewall of the pool, and the end with the air sensor emerges from the water line, water drains from the float chamber and the switch is activated to either directly interrupt the flow of electrical power to the pump motor, or to send a signal to the IC controller to effect the immediate or delay interruption of power to the pump motor. The same sequence of events occurs during operation of an in-ground pool of the "beach" type design, where one end has a sloping bottom or side that starts at ground level. Once the forward end of the moving cleaner emerges from the water, the flow of water is interrupted for a brief time and then resumed in the opposite direction to propel the unit down the slope to continue its scanning pattern.

As will be understood from the preceding description and from that which follows, this aspect of the invention comprehends various alternative means for interrupting the flow of the water jet. For example, if the pressurized water stream is delivered via hose 152 from a source external to the cleaner, e.g., the pool's built-in filter pump, an electro-mechanical bypass valve (not shown) located adjacent the hose fitting at the sidewall of the pool can be activated for a predetermined period of time to divert the flow of water from the hose directly into the pool. When the flow of water W is interrupted, the flap valve 46 of valve assembly 40 changes position and the cleaner reverses direction when the flow W is resumed.

As will be understood by one of ordinary skill in the art, the means of generating signals directed to the control circuit can also be combined. For example, an air sensor of the float type can be combined with, or fabricated from a magnetic material and installed proximate a magnetic sensor so that a change in position of the float when it is no longer immersed in water produces a signal in the magnetic sensor circuit.

The flow of water W can also be interrupted by a water-driven turbine timer having a plurality of pre-set or adjustable timing sequences. For example, a water-powered cam or step-type timer in combination with a by-pass or diverter valve located downstream is installed on the hose 152 from the external source of pressurized water. As water flows through the hose, the timer mechanism is advanced to a position at which the associated by-pass valve is actuated and the flow is diverted into the pool for a predetermined period of time. The turbine timer then advances to the next position at which the by-pass valve moves to the main flow position to redirect water to the cleaner, which now moves in the opposite direction. In this embodiment, the by-pass/diverter valve can comprise an adjustable pinch valve that compresses the hose to interrupt flow to cleaner 10.

In another preferred embodiment, the rpms of the pump and/or drive motor are monitored and if the rpm decreases below a certain minimum, as when the impeller is jammed by a piece of debris that escaped the filter, the power to the pump motor is interrupted. If the rpms exceed a maximum, as when the unit is no longer submerged and the motor is running under a no-load condition, the power is interrupted to both pump and drive motors. This will constitute an important

24

safety feature, where the cleaner is turned on while it is not in the pool, either by inadvertence, or by small children playing with the unit.

We claim:

1. A self-propelled cleaning apparatus for cleaning a submerged surface of a pool or tank, comprising:
  - a housing having a front portion as defined by the direction of movement of the apparatus when propelled by a water jet, an opposing rear portion and adjoining side portions defining the periphery of the apparatus, and a baseplate with at least one water inlet;
  - rotationally-mounted supports coupled proximate the front and rear portions of the housing to enable movement of said apparatus over the submerged surface;
  - a water pump mounted in the interior of said housing, said water pump being configured to draw water and debris from the pool or tank through the at least one water inlet for filtering; and
  - a stationary directional discharge conduit in fluid communication with the water pump and having at least one discharge opening through which a pressurized stream of water forming the water jet is directionally discharged at a predetermined angle that is acute with respect to the surface over which the apparatus is moving.
2. The apparatus of claim 1 in which the discharge conduit is linear in shape.
3. The apparatus of claim 1, wherein a portion of the discharge conduit terminating in the at least one discharge opening is fixed at a predetermined upward angle with respect to the surface over which the apparatus is moving, wherein the water jet discharged produces a resultant force vector that crosses a plane passing through between the axes of rotation of the front and rear rotationally-mounted supports.
4. The apparatus of claim 3 in which the resultant force vector crosses the plane proximate the axis of rotation of the supports mounted proximately the front of the apparatus.
5. The apparatus of claim 3, wherein the resultant force vector discharged from said discharge opening includes a longitudinal force vector component and a vertical force vector component, said longitudinal force vector component being aligned with the longitudinal axis of the apparatus and being greater than the vertical force vector component.
6. The apparatus of claim 1, wherein the discharge conduit has at least two discharge openings, each of which discharge openings is located at opposite ends of the discharge conduit and each of which discharge openings is configured to produce a downwardly directed resultant force vector in the respective discharged water jet, the resultant vector having a longitudinal force vector component that is larger than the vertical force vector component.
7. The apparatus of claim 1, wherein the rotationally-mounted supports comprise first and second pairs of axially mounted wheels respectively positioned proximate the front and rear portions of the housing.
8. The apparatus of claim 7, wherein a portion of the discharge conduit terminating in the at least one discharge opening is angled upward with respect to an adjacent portion of the discharge conduit to produce a resultant force vector in the water jet discharged from said at least one discharge opening that is directed to pass through the plane of the axis of rotation of the pair of wheels at the front portion of the apparatus.
9. The apparatus of claim 8, wherein the resultant force vector discharged from said at least one discharge opening includes a longitudinal force vector component and a vertical force vector component, said longitudinal force vector com-

US 8,273,183 B2

25

ponent being aligned with the longitudinal axis of the apparatus and being greater than the vertical force vector component.

10. The apparatus of claim 7, wherein each pair of wheels is mounted on an axle extending transversely across the housing of the apparatus.

11. The apparatus of claim 10, wherein a portion of discharge conduit adjacent the at least one discharge opening is angled upwardly with respect to the discharge conduit to produce a resultant force vector in the water jet discharged from said at least one discharge opening that is directed to a position that is proximate to, and rearwardly displaced from the axle of the front pair of wheels.

12. The apparatus of claim 10, wherein a portion of the discharge conduit terminating adjacent the at least one discharge opening is angled upwardly with respect to the discharge conduit to produce a resultant force vector in the water jet discharged that is directed to intersect the axle of the front pair of wheels.

13. The apparatus of claim 1 further comprising at least one filter assembly positioned to filter water from the at least one water inlet prior to its passage through the directional discharge conduit.

14. The apparatus of claim 13, wherein the at least one filter assembly is mounted within the housing of the cleaning apparatus.

15. The apparatus of claim 13, wherein the at least one filter assembly is mounted externally from the housing of the cleaning apparatus.

16. The apparatus of claim 1, wherein water drawn into the at least one water inlet flows through a filter prior to its discharge as the water jet to propel the pool cleaner in a forward direction of movement.

17. The apparatus of claim 1 further comprising a water jet valve located between the pump discharge outlet and the at least one discharge opening in the discharge conduit, the water jet valve being operable between first and second discharge positions to direct the water jet in generally opposite directions.

18. The apparatus of claim 17, wherein the pressurized water stream discharged from the pump discharge outlet undergoes only one right-angle change of direction before being discharged from the apparatus to move over the submerged surface of the pool in a direction that is determined by the position of the water jet valve.

19. The apparatus of claim 1, wherein a portion of the discharge conduit terminating in the at least one discharge opening is fixed at a predetermined upward angle with respect to the surface over which the apparatus is moving, wherein the water jet discharged produces a resultant force vector that crosses a plane passing through the axes of rotation of the front rotationally-mounted supports.

26

20. A self-propelled cleaning apparatus for cleaning a submerged surface of a pool or tank, said apparatus being propelled by the discharge of a water jet, the apparatus comprising:

a housing including a baseplate with at least one water inlet, a front portion, a rear portion and opposing side portions defining the periphery of the apparatus, said front portion being defined with respect to the forward directional movement of the apparatus when propelled by the water jet;

rotationally-mounted supports coupled to the housing to enable movement of said apparatus over the submerged surface;

a water pump mounted in the interior of said housing, said water pump configured to draw water and debris from the pool or tank through the at least one water inlet for filtering, and a pump discharge outlet for emitting a pressurized stream of filtered water;

a directional discharge conduit in fluid communication with the pump discharge outlet, the discharge conduit having at least one discharge opening through which the water jet is directionally discharged from the apparatus at a predetermined angle that is less than normal with respect to the surface beneath the apparatus.

21. A method for cleaning a submerged surface of a pool or tank, comprising the steps of:

providing a self-propelled cleaning apparatus, said cleaning apparatus including a housing having a baseplate with at least one water inlet, and further including a front portion as defined by the direction of movement of the cleaning apparatus when propelled by a water jet, an opposing rear portion and adjoining side portions defining the periphery of the apparatus, rotationally-mounted supports coupled to the housing to enable movement of said apparatus over the submerged surface, a water pump mounted in the interior of said housing, and a directional discharge conduit in fluid communication with the water pump and having at least one discharge opening;

activating the water pump to draw water and debris from the pool or tank through the at least one water inlet;

filtering the water drawn into the housing;

discharging the filtered water through the directional discharge conduit at an acute angle with respect to the surface over which the apparatus is moving, said discharged filtered water forming a water jet having a resultant force vector acutely angled towards the surface beneath the apparatus; and

propelling the apparatus in a forward direction of movement.

\* \* \* \* \*

UNITED STATES PATENT AND TRADEMARK OFFICE  
**CERTIFICATE OF CORRECTION**

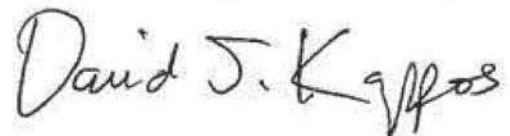
PATENT NO. : 8,273,183 B2  
APPLICATION NO. : 13/135684  
DATED : September 25, 2012  
INVENTOR(S) : Erlich et al.

Page 1 of 1

It is certified that error appears in the above-identified patent and that said Letters Patent is hereby corrected as shown below:

Claim 1, Column 24, Line 24, after "respect" insert --to--.

Signed and Sealed this  
Twenty-fifth Day of December, 2012

A handwritten signature in black ink that reads "David J. Kappos". The signature is written in a cursive, slightly slanted style.

David J. Kappos  
*Director of the United States Patent and Trademark Office*

[Trials@uspto.gov](mailto:Trials@uspto.gov)  
Tel: 571-272-7822

Paper 18  
Entered: August 23, 2013

UNITED STATES PATENT AND TRADEMARK OFFICE

---

BEFORE THE PATENT TRIAL AND APPEAL BOARD

---

ZODIAC POOL SYSTEMS, INC.  
Petitioner

v.

AQUA PRODUCTS, INC.  
Patent Owner

---

Case IPR2013-00159 (BJM)  
Patent 8,273,183 B2

---

Before BRIAN J. McNAMARA, RAMA G. ELLURU, and JAMES B. ARPIN,  
*Administrative Patent Judges.*

ARPIN, *Administrative Patent Judge.*

DECISION  
Institution of *Inter Partes* Review  
*37 C.F.R. § 42.108*

Case IPR2013-00159  
Patent 8,273,183 B2

## I. INTRODUCTION

Zodiac Pool Systems, Inc. (“Petitioner”) filed a petition to institute an *inter partes* review of claims 1-14, 16, and 19-21 of Patent No. US 8,273,183 B2 (Ex. 1006; the “’183 Patent”) (Paper 5; “Pet.”). Aqua Products, Inc. (“Patent Owner”) filed a patent owner preliminary response (Paper 17; “Prelim. Resp.”). We have jurisdiction under 35 U.S.C. § 314.

The standard for instituting an *inter partes* review is set forth in 35 U.S.C. § 314(a) which provides as follows:

**THRESHOLD** -- The Director may not authorize an *inter partes* review to be instituted unless the Director determines that the information presented in the petition filed under section 311 and any response filed under section 313 shows that there is a reasonable likelihood that the petitioner would prevail with respect to at least 1 of the claims challenged in the petition.

Upon consideration of the petition and patent owner preliminary response, we determine that the information presented in the petition establishes that there is a reasonable likelihood that Petitioner would prevail with respect to claims 1-9, 13, 14, 16, and 19-21 of the ’183 Patent. Accordingly, pursuant to 35 U.S.C. § 314, we authorize an *inter partes* review to be instituted as to claims 1-9, 13, 14, 16, and 19-21 of the ’183 Patent.

### A. *Related Proceedings*

The ’183 Patent is involved in concurrent district court litigation captioned *Aqua Products, Inc. v. Zodiac Pool Systems, Inc.*, 1:12-cv-09342-TPG (S.D.N.Y.). See Pet. 1.

Case IPR2013-00159  
 Patent 8,273,183 B2

*B. The '183 Patent*

The '183 Patent relates to self-propelled apparatus and methods for controlling such apparatus for cleaning a submerged surface of a pool or tank. '183 Patent, col. 1, ll. 22-26. Although such apparatus are propelled by a water jet to move generally in a forward direction, the movement of such apparatus is random. *Id.* at col. 2, ll. 57-59. The '183 Patent describes methods for controlling the scanning and traversing patterns of the cleaning apparatus with respect to the bottom and sidewalls of the pool or tank. *Id.* at col. 1, ll. 22-26. In the '183 Patent, “[r]eferences to the front or forward end of the cleaner will be relative to its then-direction of movement.” *Id.* at col. 4, ll.11-12.

An apparatus, as recited in the claims and said to be suitable for control according to the recited methods, is illustrated in Figure 1, reproduced below:

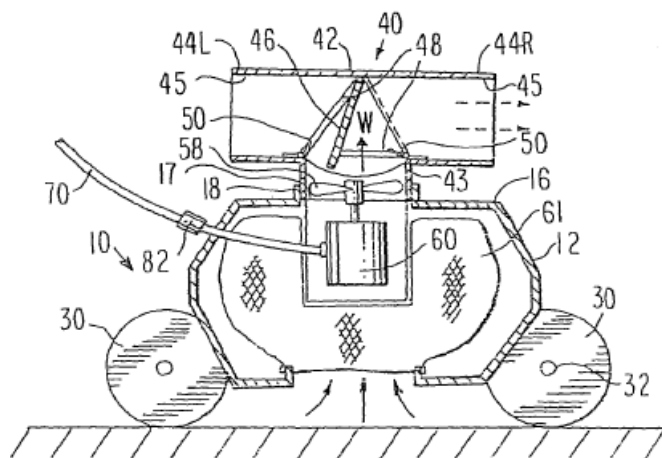


FIG. 1

In Figure 1, a schematic illustration of a cross-sectional, side view of a pool or tank cleaner apparatus 10 depicts an embodiment of the directional water jet, or discharge

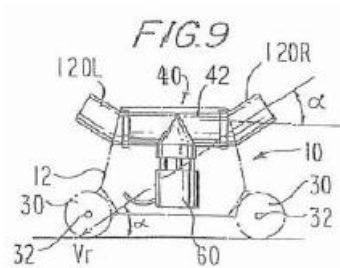
Case IPR2013-00159  
Patent 8,273,183 B2

conduit, recited in claims 1 and 20. '183 Patent, col. 7, ll. 1-3. A water inlet (not numbered) is disposed through housing 12 and below a motor-driven water pump 60, whereby pump motor 60 draws water and pool or tank debris through the water inlet for filtering. *Id.* at col. 8, ll. 58-61. Water drawn through the water inlet may pass through a filter 61, and pool or tank debris may be entrained by filter 61. *Id.* Pool cleaner 10 further comprises a valve assembly 40 forming a pump outlet that is mounted above pump motor 60. The device uses an impeller 58 to drive water “W” through a housing aperture 17 and into a valve assembly 40. *Id.* at col. 9, ll. 4-8.

As depicted in the embodiment of Figure 1, “valve assembly 40 comprises a generally T-shaped housing 42 with depending leg 43 having a first end that is secured to a cleaner housing flange 18, and a second end that is in fluid communication with discharge conduits 44R and 44L.” *Id.* at ll. 8-12. In Figure 1, the angle formed between the surface over which pool cleaner 10 is moving and discharge conduits 44R and 44L is equal to or is substantially equal to zero, *i.e.*, discharge conduits 44R and 44L are substantially parallel to the surface of movement. Thus, discharge conduits 44R and 44L are at acute angles, *i.e.*, angles less than 90° (*see* claim 1) or less than normal (*see* claim 20) with respect to the surface of movement. *Id.* at col. 6, ll. 7-11.

Alternatively, an apparatus, as recited in the claims and suitable for control according to the recited methods, is illustrated in Figure 9, reproduced below:

Case IPR2013-00159  
 Patent 8,273,183 B2



In Figure 9, a preferred embodiment of pool cleaner 10 is depicted having valve assembly 40 in which discharge conduits 44R and 44L through their associated elbows 120R and 120L project through the sidewalls of a pool cleaner housing 12 at angle  $\alpha$  that is less than  $90^\circ$  and greater than  $0^\circ$ , *i.e.*, is acute or less than normal, with respect to the surface of movement of pool cleaner 10. *Id.* at col. 10, ll. 47-48, 60-64; *see* Claims 1 and 20.

Referring again to Figure 1, housing 12 is propelled by the water jet created by the selective ejection of water from pump motor 60 through discharge conduits 44R and 44L. *Id.* at col. 9, ll. 24-53; Figs. 1-3. Thus, the direction of movement may change depending upon which conduit ejects the water. *Id.* In the alternative embodiment depicted in Figure 9, elbows 120R and 120L cause a force vector component generated by the water jet to move housing 12 in a direction away from the discharged water jet and another force vector component to urge housing 12 downward against the pool or tank surface over which pool cleaner 10 moves. *Id.* at col. 10, ll. 47-51; Fig. 8. Pool cleaner 10 further comprises rotationally-mounted supports, *i.e.*, wheels 30 mounted on a pair of axles 32. *Id.* at col. 10, ll. 47-66. Each of axles 32 is disposed proximate to one of a front and an opposing rear end of pool cleaner 10, as defined by the direction of movement. *Id.* at col. 10, l. 64-col.



Case IPR2013-00159  
Patent 8,273,183 B2

11, l. 3; *see also id. at col. 5, ll. 9-12* (“[R]eferences to the front and rear of the cleaning apparatus or its housing will be with respect to the direction of its movement.”).

*C. Illustrative Claims*

Challenged claims 1, 20, and 21 are independent; and claims 2-14 and 16 depend, directly or indirectly, from independent claim 1. Claim 1 is illustrative and is reproduced below to demonstrate the claimed subject matter:

1. A self-propelled cleaning apparatus for cleaning a submerged surface of a pool or tank, comprising:

a housing having a front portion as defined by the direction of movement of the apparatus when propelled by a water jet, an opposing rear portion and adjoining side portions defining the periphery of the apparatus, and a baseplate with at least one water inlet;

rotationally-mounted supports coupled proximate the front and rear portions of the housing to enable movement of said apparatus over the submerged surface;

a water pump mounted in the interior of said housing, said water pump being configured to draw water and debris from the pool or tank through the at least one water inlet for filtering; and

a stationary directional discharge conduit in fluid communication with the water pump and having at least one discharge opening through which a pressurized stream of water forming the water jet is directionally discharged at a predetermined angle that is acute with respect to the surface over which the apparatus is moving.

Case IPR2013-00159  
 Patent 8,273,183 B2

*D. Prior Art Relied Upon*

Petitioner relies upon the following prior art references:

Myers	US 3,321,787	May 30, 1967	(Ex. 1001)
Henkin	US 3,936,899	Feb. 10, 1976	(Ex. 1002)
Pansini	US 4,100,641	July 18, 1978	(Ex. 1003)
Altschul	US 4,429,429	Feb. 7, 1984	(Ex. 1004)

*E. The Asserted Grounds*

Petitioner alleges that the challenged claims are anticipated under 35 U.S.C. § 102(b) by Myers or unpatentable as obvious under 35 U.S.C. § 103(a) based upon the listed prior art references in various combinations. The specific grounds are detailed in the table below:

Grounds	Claims	Statutory Basis	Applied Reference(s)
1	1-4, 13, 14, 16, and 19-21	35 U.S.C. § 102(b)	Myers
2	1-5 and 19-21	35 U.S.C. § 103(a)	Henkin and Myers
3	1-9 and 19-21	35 U.S.C. § 103(a)	Pansini and Myers
4	1-5, 7-12, and 19-21	35 U.S.C. § 103(a)	Altschul and Myers

Case IPR2013-00159  
Patent 8,273,183 B2

## II. ANALYSIS

### A. *Claim Construction*

In an *inter partes* review, claim terms in an unexpired patent are given their broadest reasonable interpretation in light of the specification of the patent in which they appear. 37 C.F.R. § 42.100(b); *see* Office Patent Trial Practice Guide, 77 Fed. Reg. 48756, 48766 (Aug. 14, 2012). Under the broadest reasonable interpretation standard, claim terms are given their ordinary and customary meaning as would be understood by one of ordinary skill in the art in the context of the entire disclosure. *In re Translogic Tech., Inc.*, 504 F.3d 1249, 1257 (Fed. Cir. 2007). Any special definition for a claim term must be set forth in the specification with reasonable clarity, deliberateness, and precision. *In re Paulsen*, 30 F.3d 1475, 1480 (Fed. Cir. 1994). In this regard, however, we are careful not to read a particular embodiment appearing in the written description into the claim if the claim language is broader than the embodiment. *In re Van Geuns*, 988 F.2d 1181, 1184 (Fed. Cir. 1993).

“Petitioner submits, for purposes of the *inter partes* review only, that the claim terms are presumed to take on their ordinary and customary meaning that the terms would have to one of ordinary skill in the art in view of the Specification of the ’183 patent.” Pet. 4. Patent Owner contends, however, that, given the interpretation of certain claim terms, Myers alone does not disclose all of the elements, and Myers in combination of one of the other applied references does not teach or suggest all of the limitations of the claims for which review is sought in the petition. Prelim. Resp. 2-4, 12-18. In particular, Patent Owner contends that, in

Case IPR2013-00159

Patent 8,273,183 B2

view of the interpretation of the claim terms: “a stationary directional discharge conduit,” “a front portion as defined by the direction of movement of the apparatus when propelled by a water jet,” “an opposing rear portion,” “adjoining side portions,” and “rotationally-mounted supports coupled proximate the front and rear portions of the housing”; the challenged claims are neither anticipated nor rendered obvious by the cited art. *Id.* at 2-4. For the purpose of determining whether to institute *inter partes* review, we interpret those claim terms which Patent Owner relies upon to distinguish the claims over the references.

1. *a stationary directional discharge conduit*

Initially, we note that claim 1 limits the apparatus to “*a stationary directional discharge conduit*” (emphasis added). Referring to the language of claim 1 and to the Specification, we find no definition for a stationary directional discharge conduit. Although the Specification describes various embodiments of such discharge conduits, *e.g.*, discharge conduits 44R and 44L, we do not limit the interpretation of this term to such embodiments. *Van Geuns*, 988 F.2d at 1184. Considering the language of claim 1, we note that a definition of the term “stationary” is “having a fixed position, not moveable.” RANDOM HOUSE WEBSTER’S COLLEGE DICTIONARY, 1278 (2nd Random House ed. 1999). Moreover, a definition of the term “directional” is “of, pertaining to, or indicating direction.” *Id.* at 374. Petitioner notes that, during prosecution, Patent Owner argued in overcoming the Examiner’s proposed Restriction Requirement that

[a] pool cleaner apparatus [that] employs *at least one* discharge opening through which the water jet is directionally discharged from the cleaning apparatus at a predetermined angle that is less than normal

Case IPR2013-00159  
Patent 8,273,183 B2

with respect to the surface beneath the apparatus. *At least one* angled discharge outlet 120R and/or 120L extends from the jet valve assembly 40, as described in paragraphs 0091 through 0094 and shown in Figs. 8 and 9 of the present application.

Pet. 6 (quoting Response to Restriction Requirement (Ex. 1005) 2 (emphases added)). Therefore, consistent with the language of claim 1, the description in the Specification, and the prosecution of the '183 Patent, the broadest reasonable interpretation of “*a stationary directional discharge conduit*” is one or more discharge conduits or at least one discharge conduit, each of which is stationary and is oriented in a particular direction, *e.g.*, that does not move and is aligned relative to a given axis of the apparatus. *KCJ Corp. v. Kinetic Concepts, Inc.*, 223 F.3d 1351, 1356 (Fed. Cir. 2000)(“an indefinite article ‘a’ or ‘an’ in patent parlance carries the meaning of ‘one or more’ in open-ended claims containing the transitional phrase ‘comprising’”); *see, e.g.*, '183 Patent, col. 4, ll. 18-20; Figs. 1-3, 8, 9.

2. *a front portion as defined by the direction of movement of the apparatus when propelled by a water jet*

Independent claim 1 recites that a housing has “*a front portion as defined by the direction of movement of the apparatus when propelled by a water jet*” (emphasis added). This language describes the front portion based on (1) the direction of movement of the apparatus, and (2) the time, *e.g.*, “when” the apparatus is propelled “by a water jet.”

With respect to the first basis for describing the “front portion,” the Specification states that the movement of the apparatus is random. '183 Patent, col.

Case IPR2013-00159  
Patent 8,273,183 B2

5, ll. 4-9. The Specification further explains that the “[r]eference to the front or forward end of the cleaner will be *relative* to its *then*-direction of movement.” *Id.* at col. 4, ll. 11-12 (emphases added); *see also id.* at col. 5, ll. 9-12. Moreover, unless otherwise controlled, as noted above, this movement is random. *Id.* at col. 2, ll. 57-59. Thus, the “front portion” of the housing may change with time, and no single portion of the housing may be identified exclusively as the “front portion.”

Similarly, with respect to the second basis for describing the “front portion,” *i.e.*, “when” the apparatus is propelled by a water jet, the Specification states that “the invention comprehends a method of propelling a pool or tank cleaner by means of a water jet that is discharged [from a discharge conduit] in *at least* a first and a second direction that result in opposite translational directions.” *Id.* at col. 4, ll. 50-54 (emphasis added). Nevertheless, we do not interpret the language of claim 1 as limited to such an embodiment. The scope of this limitation is determined by the number and direction of orientation of the discharge conduits.

First, claim 1 recites that the apparatus comprises “*a* stationary directional discharge conduit” (emphasis added). As noted above, under the broadest reasonable interpretation, this limitation describes one or more such conduits or at least one such conduit. Second, although embodiments of the invention are depicted as having opposing discharge conduits, *e.g.*, discharge conduits 44R and 44L, *supra*, we do not read a particular embodiment appearing in the written description into the claim, especially if, as here, the claim language is broader than the particular embodiment. *Van Geuns*, 988 F.2d at 1184; *see* ’183 Patent, Figs. 1, 9 (depicting discharge conduits 44R and 44L). Third, during prosecution, Applicants argued that

Case IPR2013-00159  
Patent 8,273,183 B2

the claimed apparatus employ “*at least one* discharge opening through which the water jet is directionally discharged.” Pet. 6 (quoting Response to Restriction Requirement 2 (emphasis added)).

Thus, we interpret this limitation as providing that the location of the front portion on the apparatus varies with the movement of the apparatus, both over time and depending upon the number and direction of orientation of one or more discharge conduits through which the water jet is discharged.

3. *an opposing rear portion and adjoining side portions*

Claim 1 recites that the front portion, together with “an opposing rear portion and adjoining side portions” define the periphery of the apparatus. *See also* ’183 Patent, Abstract. Moreover, the Specification states that “references to the front *and rear* of the cleaning apparatus or its housing will be with respect to the direction of its movement.” ’183 Patent, col. 5, ll. 9-12 (emphasis added). Thus, consistent with the broadest reasonable interpretation of the “front portion,” the “rear portion” is opposite to the “front portion” of the apparatus and, like the front portion, the location of the rear portion on the apparatus varies with the movement of the apparatus, both over time and depending upon the number and direction of orientation of one or more discharge conduits through which the water jet is discharged. Because the side portions adjoin the front and rear portions, as with the front and rear portions, we interpret the location of the side portions on the apparatus to vary with the movement of the apparatus, both over time and depending upon the number and direction of orientation of one or more discharge conduits through which the water jet is discharged. Therefore, the rear and side portions are defined relative

Case IPR2013-00159  
Patent 8,273,183 B2

to the varying front portion.

4. *rotationally-mounted supports coupled proximate the front and rear portions of the housing*

Referring to the language of claim 1 and to the Specification, we again find no definition agreed upon by the parties for rotationally-mounted supports. The Specification, however, describes that

[a] further object of the invention is to provide an improved apparatus and method for varying the position of one or more of *the wheels or other support means* of the cleaner in order to vary the directional movement and scanning patterns of the apparatus with respect to the bottom surface of the pool or tank being cleaned.

'183 Patent, col. 3, ll. 35-40 (emphasis added). Further, the Specification describes that the cleaner may move “on *supporting wheels, rollers or tracks* that are aligned with the longitudinal axis of the cleaner body when it moves in a straight line.” '183 Patent, col. 4, ll. 8-11 (emphasis added). Referring, for example, to Figure 1, wheels 30 mounted on axles 32 are depicted as disposed at either end of pool cleaner 10.

Considering the language of claim 1, we note that a definition of the verb “to support” is “to bear or hold up (a load, mass, structure part, etc.),” and a definition of the noun “support” is “a person or thing that supports, esp. financially.” RANDOM HOUSE WEBSTER’S COLLEGE DICTIONARY at 1313. Moreover, a definition of the noun “rotation” is “the act of rotating; a turning around as on an axis.” *Id.* at 1145. Thus, we interpret the term “rotationally-mounted supports” to recite two or more things (including, but not limited to wheels, rollers, and tracks) that support or hold up the housing of the apparatus and which are mounted to the housing, so that the



Case IPR2013-00159  
Patent 8,273,183 B2

supports may turn around, for example, on an axis. Nevertheless, because the front and rear of the apparatus are determined by its direction of movement at any particular point in time, whether the rotationally-mounted supports are “coupled proximate to the front and rear portions of the housing” depends upon the direction of movement of the apparatus at a given time.

### III. DECISION ON PETITION

For the reasons described below, we institute an *inter partes* review on the grounds that of each of claims 1-9, 13, 14, 16, and 19-21 is anticipated by Myers and on the grounds that each of these same claims is obvious over the combination of Henkin and Myers and obvious over the combination of Pansini and Myers. We deny the petition with respect to the grounds that claims 10-12 are obvious over the combination of Altschul and Myers.

Patent Owner asserts that Henkin, relied upon by Petitioner in the request for *inter partes* review, was considered by the Examiner during the prosecution of the claims for which review is sought. Prelim. Resp. 6 (ftnt. 3 (citing 35 U.S.C. § 325(d))). Patent Owner concludes that the Board should “take into account” that the Examiner did not consider Henkin particularly pertinent during prosecution, and that the Board should not institute trial on the proposed grounds for review based on Henkin. Prelim. Resp. 6 (ftnt. 3).

Petitioner, however, presents different arguments and new supporting evidence here that were not before the Examiner. Therefore, we decline to deny the proposed grounds of review solely on the basis of 35 U.S.C. § 325(d).

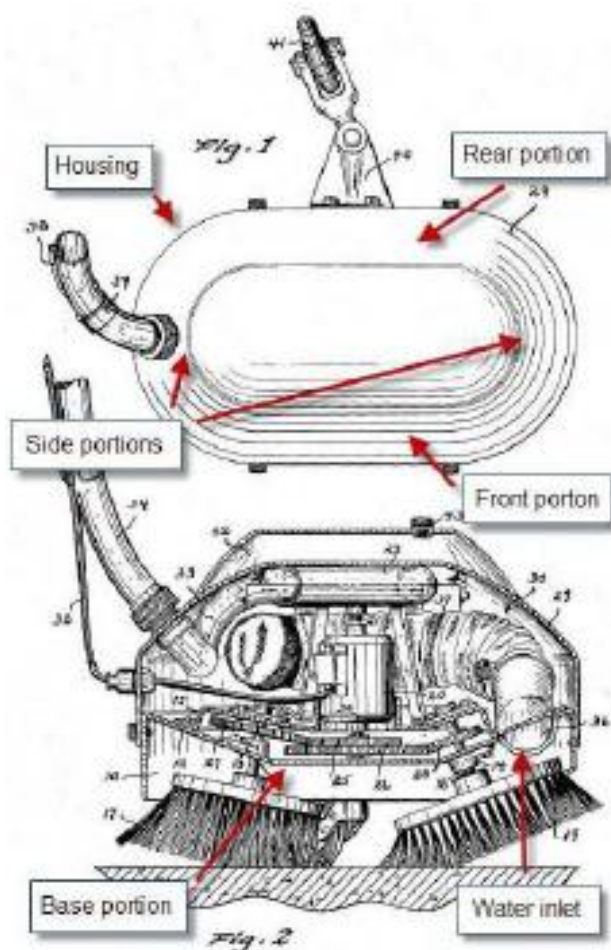
Case IPR2013-00159  
 Patent 8,273,183 B2

#### IV. GROUNDS FOR REVIEW

##### A. *Anticipation by Myers*

Petitioner argues that Myers discloses, expressly or inherently, each and every element of claims 1-4, 13, 14, 16, and 19-21. Pet. 8-11, 21-23, 26-27, 40-42, 45-47, and 52-53. With the exception of certain elements of claims 3 and 4, we agree with Petitioner.

Figures 1 and 2 of Myers (Ex. 1001) are reproduced below, including Petitioner's annotations. *See* Pet. 8 (depicting annotated versions of Myers, Figs. 1 and 2).



Case IPR2013-00159  
Patent 8,273,183 B2

Figure 1 depicts a top plan view of a swimming pool cleaning means according to Myers's invention, and Figure 2 depicts a cross-sectional view of the swimming pool cleaning means, as depicted in Myers's Figure 1. Myers, col. 1, ll. 42-43. Petitioner annotated these figures to identify elements of Myers's device corresponding to the housing, including front, rear and side portions; the base portion, *e.g.*, the baseplate; and the water inlet. In view of our claim interpretation, we consider the identifications of the front, rear, and side portions in Petitioner's annotated Figure 2, as merely illustrative.

Referring to Figures 1 and 2, Petitioner argues that Myers depicts a self-propelled cleaning apparatus for cleaning a submerged surface of a pool or tank. Pet. 8; *see* '183 Patent, Claim 1 (preamble). In particular, Myers indicates that its "invention relates to a swimming pool cleaning device and more particularly to a cleaning means that is erratically self-propelled over the bottom surface of the swimming pool." Pet. 8 (quoting Myers, col. 1, ll. 8-11). Moreover, Petitioner argues that Myers's device includes the claimed "housing," *i.e.*, a hood 29, having front, opposing rear, and adjoining side portions, which define the periphery of the device. Pet. 8. Further, Petitioner argues that Myers's device includes a baseplate, *i.e.*, an outer area 12, through which a water inlet, *i.e.*, a passageway 36, communicates with the outside of the device. Pet. 8; *see* Myers, col. 1, 50-52; col. 2, ll. 22-24.

Referring to Figure 2, Myers depicts "a surface engaging element such as a brush or like 17" which is "rotatably mounted" on shafts at either end of hood 29. Myers, col. 1, ll. 55-61. Petitioner argues that these surface engaging elements 17 correspond to the

Case IPR2013-00159  
Patent 8,273,183 B2

rotationally-mounted supports, as recited in claim 1. Pet. 8.

Finally, referring to Figure 2, Myers discloses that a flexible conduit 33 may be connected to outlet opening 32 of rotary pump 13 and may pass through and terminate just beyond hood 29. Myers, col. 2, ll. 8-13. An elongated, flexible conduit, *e.g.*, a hose 34, may be attached *detachably* to the outlet portion of conduit 33 and may extend to a point outside the swimming pool. *Id.* at ll. 13-18. Myers further explains that:

if the electric motor is operated as a motor, and the conduit 33 is detached [from conduit 34], *the water exiting from the unit and into the pool will provide a jet force to move the unit.* Also due to the gear wheel sizes and other placed elements more weight will be borne on by one brush than the other brush. This is particularly true if the conduit 33 is attached.

Myers, col. 3, ll. 6-12 (emphasis added). Thus, Petitioner argues that Myers discloses the stationary directional discharge conduit, as recited in claim 1. Pet. 10-11.

Patent Owner disagrees with Petitioner's reading of Myers' disclosure on the language of claim 1 for three reasons. Prelim. Resp. 12-17. First, Patent Owner contends that Myers's surface engaging elements 17 do not disclose rotationally-mounted supports, as recited in claim 1. *Id.* at 12-13. Second, Patent Owner contends that Myers does not disclose a housing having a front portion defined by the direction of the movement of the apparatus when propelled by water jet. *Id.* at 14-16. Third, Patent Owner contends that Myers does not disclose a directional discharge conduit. *Id.* at 16-17. For the reasons set forth below, we are not persuaded by Patent Owner that Myers fails to disclose any of these elements of claim 1.

In its first argument, Patent Owner contends that Petitioner inconsistently argues that Myers's surface-engaging elements 17 *are* rotationally-mounted supports for

Case IPR2013-00159  
Patent 8,273,183 B2

purposes of the anticipation grounds of unpatentability, and that Myers's surface-engaging elements 17 *may be replaced* with wheels, taught by Henkin, Pansini, or Altschul, in the obviousness grounds for unpatentability. *Id.* In view of these allegedly inconsistent arguments, Patent Owner contends that Petitioner concedes that Myers lacks an element of claim 1, as well as claims 20 and 21, of the '183 Patent. We disagree.

The conclusions that a reference anticipates a claim and that the same reference in combination with another renders that same claim obvious are not inherently inconsistent. *See Cohesive Technologies, Inc. v. Waters Corp.*, 543 F.3d 1351, 1364 (Fed. Cir. 2008) (“[A]lthough anticipation can be proven inherently, proof of inherent anticipation is not the same as proof of obviousness. Thus, ‘it does not follow that every technically anticipated invention would also have been obvious.’”; citations omitted). Petitioner argues both that Myers's surface engaging elements 17 disclose rotationally-mounted supports, as recited in claim 1, and that a person of ordinary skill in the relevant art would have had reason to replace Myers's surface engaging elements 17 with wheels, a preferred embodiment of the rotationally-mounted supports disclosed in the '183 Patent, in view of the teachings regarding such wheels in Henkin, Pansini, or Altschul. Prelim. Resp. (citing Pet. 8-9, 12, 15-16, 18).

With respect to anticipation, the question here is whether Petitioner has demonstrated that Myers's surface engaging elements 17 disclose rotationally-mounted supports, as recited in claim 1. As noted above, we interpret the term “rotationally-mounted supports” broadly to recite two or more things which support or hold up the housing of the apparatus and which are mounted to the housing, so that the supports

Case IPR2013-00159  
Patent 8,273,183 B2

may turn around, for example, on an axis. Consequently, we agree with Petitioner that Myers discloses this element of claim 1.

In its second argument, Patent Owner contends that, because Myers's device moves "erratically" over the bottom surface of the pool, Patent Owner contends that Myers does not teach the claimed "front portion." *Id.* at 14-15 (citing Myers, col. 2, ll. 47-48; col. 2, l. 34-col. 3, l. 5). Again, we disagree.

We have construed the claim language as providing that the location of the front portion on the apparatus varies with the movement of the apparatus, both over time and depending upon the number and direction of orientation one or more discharge conduits through which the water jet is discharged. We agree with Patent Owner that Myers describes that its device moves "erratically" across the bottom surface of the pool. Myers, col. 1, ll. 8-11, 22-24; col. 2, l. 34-col. 3, l. 5. We determine, however, that Myers's device has an identifiable, if varying, "front portion" consistent with our interpretation of the element recited in claim 1, and that Petitioner's identification of front, rear, and side portions is merely illustrative. In addition, although the movement of Myers's device may be influenced by the rotation of surface engaging elements 17 (Myers, col. 2, l. 55-col. 3, l. 5), such additional influences are not precluded by the language of claim 1. Therefore, we are persuaded that Petitioner has demonstrated that Myers discloses this element, as recited in claim 1 of the '183 Patent.

In its third argument, Patent Owner contends that Myers does not disclose a directional discharge conduit. Prelim. Resp. 16-17. In particular, Patent Owner contends that:

[a]s expressly disclosed by Myers, *the "jet force" is produced when*

Case IPR2013-00159  
Patent 8,273,183 B2

*conduit 33 . . . is detached, severing the connection between the pump outlet 32 and conduit 34.* (Myers, 3:6-8). Indeed, if conduit 33 is detached, conduit 34 (which attaches to conduit 33) would likewise have to be detached. In that event, the water stream exiting pump outlet 32 would first enter the interior of the hood 29 before exiting the opening in the hood through which conduit 33 would normally terminate if it had not been detached. Even assuming, as Myers suggests, that the stream exiting the opening in the hood 29 could constitute a “jet force,” the purpose of that “jet force” would be to contribute to the erratic movement of the Myers unit.

*Id.* at 4-5 (emphasis added; footnote omitted). We disagree with Patent Owner’s contention that Myers discloses that conduit 33 is detached from pump outlet 32.

Myers describes that “[a] flexible conduit 33 has one end *connected* to the outlet opening 32 and its other end terminating just outside the hood 29. Operatively *detachably secured* to the outer end of the conduit 33 is an elongated flexible conduit such as a rubber-like hose 34.” Myers, col. 2, ll. 11-15 (emphases added). Thus, Myers describes conduit 33 as “connected” to pump outlet opening 32, but “detachably secured” to hose 34. In the portion of Myers cited by both Patent Owner (Prelim. Resp. 4-5) and Petitioner (Pet. 10-11), Myers describes that the jet force of water exiting the Myers’s device is produced if the electric motor is operating and if “conduit 33 is *detached*.” Myers, col. 3, l. 6-9 (emphasis added). Because hose 34 is described as “detachably secured” to conduit 33, and because detaching hose 34 clearly would permit water to exit Myers’s device, we are persuaded that Myers describes that hose 34, rather than outlet opening 32, is “detached” to generate the jet force of water. Therefore, we also are persuaded that Myers discloses a directional

Case IPR2013-00159  
Patent 8,273,183 B2

discharge conduit, as recited in claim 1.

Because Patent Owner contends that the reasons discussed above apply to independent claims 20 and 21, as well as independent claim 1, we are persuaded that Petitioner has demonstrated a reasonable likelihood of prevailing on its challenge to the patentability of claims 1, 20, and 21 of the '183 Patent as anticipated by Myers.

Patent Owner contends that Petitioner fails to demonstrate that there is a reasonable likelihood of prevailing on its challenge to the patentability of claims 2-4, 13, 14, 16, and 19, which depend from independent claim 1, as anticipated by Myers, based solely on the alleged deficiencies in Myers with respect to claim 1. Prelim. Resp. 17-18.

We are not persuaded that Petitioner demonstrates a reasonable likelihood of prevailing on its challenge to the patentability of claims 3 and 4, as anticipated by Myers.

Claim 3 depends from claim 1 and recites that:

a portion of the discharge conduit terminating in the at least one discharge opening is fixed at a predetermined upward angle with respect to the surface over which the apparatus is moving, wherein the water jet discharged produces a resultant force vector *that crosses a plane passing through between the axes of rotation of the front and rear rotationally-mounted supports*

(emphasis added). We interpret this claim language to require that the plane crossed by the resultant force vector passes “between” the axes of rotation of the front and rear rotationally-mounted supports, *e.g.*, Myers’s surface engaging elements 17. We



Case IPR2013-00159  
Patent 8,273,183 B2

contrast this language with that of claim 19, which also depends directly from claim 1, and states that “the water jet discharged produces a resultant force vector that crosses a plane passing *through* the axes of rotation of the front rotationally-mounted supports” (emphasis added). *See Free Motion Fitness, Inc. v. Cybex Int’l, Inc.*, 423 F.3d 1343, 1351 (Fed. Cir. 2005) (“The doctrine of claim differentiation create[s] a presumption that each claim in a patent has a different scope.”).

Referring again to Myers’s Figure 2, Petitioner argues that Myers discloses this element as described in both claims 3 and 19 because the resultant force vector would cross a plane that passes through, *i.e.*, intersects, both the front and rear supports axes of rotation. Pet. 23 (claim 3), 42 (claim 19). Nevertheless, Petitioner fails to demonstrate that the resultant force vector would cross a plane that passes “between” both the front and rear supports axes of rotation, as further required by claim 3.<sup>1</sup> Therefore, we are not persuaded that Petitioner has demonstrated a reasonable likelihood of prevailing on its challenge to the patentability of claim 3 and of claim 4 that depends from claim 3 of the ’183 Patent, as anticipated by Myers.

---

<sup>1</sup>The axes of rotation depicted in Figure 2 of Myers are inclined toward each other. *See* Myers, Claim 11 (“the brushes having their axes at an angle to each other”). Consequently, it may not be possible to place a plane “between” these axes of rotation. In Henkin, Pansini, and Altschul, the axes of rotation are depicted as parallel to each other, and the problem presented by Myers’s configuration is not present. *See* Henkin, Fig. 4; Pansini, Fig. 3; Altschul, Fig. 4.

Case IPR2013-00159  
Patent 8,273,183 B2

*B. Unpatentability Due To Obviousness*

*1. Henkin and Myers*

Petitioner argues that Henkin discloses substantially all of the limitations of independent claim 1, except that Henkin discloses the use of an external pump, rather than an internal pump. Pet. 11-14. Like Myers, Henkin discloses an apparatus for cleaning submerged surfaces of a pool. Henkin, col. 1, ll. 46-59. Myers, however, teaches the use of an internal pump, *e.g.*, ordinary rotary pump 23. Pet. 13. Petitioner argues that a person of ordinary skill in the relevant art would have had a reason to modify the teachings of Henkin to replace the external pump with an internally-mounted pump to eliminate (1) the need for an external source of pressurized water and supply hose and (2) the need to manage the supply hose to prevent entanglement. *Id.* For the reasons set forth below, we agree with Petitioner.

Patent Owner does not dispute Petitioner's reading of the limitations of claim 1 on the disclosure of Henkin. Instead, Patent Owner disagrees with Petitioner's combination of the teachings of Henkin with those of Myers for three reasons. Prelim. Resp. 18-21. First, Patent Owner contends that Henkin *teaches away* from the incorporation of an internal pump, and, in particular, an electric pump, into its cleaner housing. *Id.* at 18-19. Second, Patent Owner contends that Petitioner fails to describe how an internal pump could be incorporated operably within Henkin's pool cleaner. *Id.* at 19-20. Third, Patent Owner contends that Petitioner fails to explain how the elimination of the supply hose "to prevent entanglement" would provide a reason to incorporate an internal pump when such an internal pump would require

Case IPR2013-00159  
Patent 8,273,183 B2

the addition of a power supply cable that also would be subject to entanglement. *Id.* at 20-21. For the reasons set forth below, we are not persuaded by Patent Owner that Petitioner's proposed combination of the teachings of Henkin and Myers is improper.

First, as the Federal Circuit has explained, a reference may be said to *teach away* when a person of ordinary skill, upon reading the reference, would be discouraged from following the path set out in the reference, or would be led in a direction divergent from the path that was taken by patentee. *In re Gurley*, 27 F.3d 551, 553 (Fed. Cir. 1994). "The fact that the motivating benefit comes at the expense of another benefit, however, should not nullify its use as a basis to modify the disclosure of one reference with the teachings of another. Instead, the benefits, both lost and gained, should be weighed against one another." *Winner Int'l Royalty Corp. v. Wang*, 202 F.3d 1340, 1349 n. 8 (Fed. Cir. 2000).

Here, referring to known underwater cleaners, Henkin states that:

those underwater cleaners which employ an electric motor have proved to be somewhat inconvenient because of the potential shock hazard. That is, since *it is normally recommended that the motor not be operated while there are swimmers in the pool, the cleaner cannot safely be left in the pool under the control of a time clock*. As a consequence, the use of such cleaners has, for the most part, been restricted to commercial applications.

Henkin, col. 1, ll. 26-35 (emphasis added). Patent Owner focuses on Henkin's warning regarding the potential dangers to swimmers presented by submerged, electric motors, disposed internal to swimming pool cleaners. Prelim. Resp. 19. We

Case IPR2013-00159  
Patent 8,273,183 B2

note, however, that the claim 1 apparatus is not limited to use in swimming pools, but also is suitable for use in tanks, *e.g.*, “commercial applications.” *See* ’183 Patent, Claim 1 (“for cleaning a submerged surface of a pool *or* tank,” emphasis added). Moreover, although the Specification may describe embodiments of the internal pump including electric motors, claim 1 merely recites a “water pump” and does not require that the recited pump be driven by an electric motor. Thus, Patent Owner’s contentions are not directed to the invention recited in claim 1 of the ’183 Patent, and we are not persuaded that Henkin teaches away from Petitioner’s proposed combination with the teachings of Myers.

Second, Patent Owner contends that Petitioner fails to describe how an internal pump could be incorporated *operably* within Henkin’s pool cleaner. Prelim. Resp. 19-20. In particular, Henkin describes “a complex manifold in which the incoming water stream from the external pump is divided into three separate streams to drive the unit’s wheels, to create a jet force to help propel the unit and to create a vacuum to draw water and debris from the pool bottom.” *Id.* at 20 (citing Henkin, col. 4, ll. 35-41; col. 5, ll. 6-18; col. 6, ll. 6-34; Fig. 4). Patent Owner contends that Petitioner fails to explain how a pump could be installed internally to operate with this manifold. *Id.*

As the Federal Circuit has explained, “[t]he test for obviousness is not whether the features of a secondary reference may be bodily incorporated into the structure of the primary reference . . . . Rather, the test is what the combined teachings of those references would have suggested to those of ordinary skill in the art.” *In re Keller*, 642 F.2d 413, 425 (CCPA 1981); *see also In re Sneed*, 710 F.2d

Case IPR2013-00159

Patent 8,273,183 B2

1544, 1550 (Fed. Cir. 1983) (“[I]t is not necessary that the inventions of the references be physically combinable to render obvious the invention under review.”); and *In re Nievelt*, 482 F.2d 965, 968 (CCPA 1973) (“Combining the *teachings* of references does not involve an ability to combine their specific structures.”). Rather, “if a technique has been used to improve one device, and a person of ordinary skill in the art would recognize that it would improve similar devices in the same way, using the technique is obvious unless its actual application is beyond his or her skill.” *KSR Int’l Co. v. Teleflex Inc.*, 550 U.S. 398, 417 (2007). Because Patent Owner has not demonstrated, at this stage of the proceeding, that the proposed combination would be beyond the skill of a person of ordinary skill in the relevant art, we are not persuaded by this contention.

Third, Patent Owner contends that Petitioner fails to explain how the elimination of the supply hose “to prevent entanglement” would provide a reason to incorporate an internal pump when such an internal pump would require the addition of a power supply cable that also would be subject to entanglement. Prelim. Resp. 20-21. As noted above, however, claim 1 does not require the use of an electrically-driven pump or a power supply cable. To the extent such an electrically-driven pump may be used, Patent Owner fails to demonstrate that the pump must use a power supply cable, instead of, for example, a battery. Thus, Patent Owner’s contentions again are not directed to the invention recited in claim 1 of the ’183 Patent, and we are not persuaded that the combination of the teachings of Henkin and Myers would require the addition of a power cable, despite the elimination of a supply hose.

Case IPR2013-00159  
Patent 8,273,183 B2

Because Patent Owner contends that the reasons discussed above apply also to independent claims 20 and 21, as well as independent claim 1 (Prelim. Resp. 21), we determine that Petitioner also has demonstrated that there is a reasonable likelihood of prevailing on its challenge to the patentability of claims 20 and 21 of the '183 Patent as unpatentable over Henkin and Myers. Patent Owner contends that Petitioner fails to demonstrate that there is a reasonable likelihood of prevailing on its challenge to the patentability of claims 2-5 and 19, which depend from independent claim 1, as unpatentable over Henkin and Myers, based solely on the alleged deficiencies in this combination of references with respect to claim 1. Prelim. Resp. 22. Therefore, in view of the foregoing discussion of claim 1, we also are persuaded that Petitioner has demonstrated that there is a reasonable likelihood of prevailing on its challenge to the patentability of claims 2-5 and 19 of the '183 Patent as unpatentable over Henkin and Myers.

## 2. *Pansini and Myers*

Petitioner argues that Pansini discloses substantially all of the limitations of independent claim 1, except that Pansini discloses the use of an external pump, rather than an internal pump. Pet. 14-17. Like Myers, Pansini discloses an apparatus for cleaning submerged surfaces of a pool. Pansini, Abstract. Myers, however, teaches the use of an internal pump, *e.g.*, ordinary rotary pump 23. Pet. 16. Petitioner argues that a person of ordinary skill in the relevant art would have had a reason to modify the teachings of Pansini to replace the external pump with an internally-mounted pump to eliminate (1) the need for an external source of

Case IPR2013-00159  
Patent 8,273,183 B2

pressurized water and supply hose, and (2) the need to manage the supply hose to prevent entanglement. *Id.* For the reasons set forth below, we agree.

Patent Owner does not dispute Petitioner's reading of the limitations of claim 1 on the disclosure of Pansini. Instead, Patent Owner disagrees with Petitioner's combination of the teachings of Pansini with those of Myers for three reasons. Prelim. Resp. 22-27. First, Patent Owner contends that Pansini *teaches away* from the incorporation of an internal pump, and, in particular, an electric pump, into its cleaner housing. *Id.* at 22-24. Second, Patent Owner contends that Petitioner fails to describe how an internal pump could be incorporated operably within Pansini's pool cleaner. *Id.* at 25. Third, Patent Owner contends that Petitioner fails to explain how the elimination of the supply hose "to prevent entanglement" would provide a reason to incorporate an internal pump when such an internal pump would require the addition of a power supply cable that also would be subject to entanglement. *Id.* at 25-26. For the reasons set forth below, we are not persuaded by Patent Owner that Petitioner's proposed combination of the teachings of Pansini and Myers is improper.

First, Patent Owner contends that "the structural configuration of the Pansini cleaner is purposefully directed to implementing an external source of pressurized water (*i.e.*, an external pump) *without the need for a booster pump or an internal pump.*" *Id.* at 24; *see* Pansini, col. 1, ll. 38-43. Because Patent Owner contends that such a booster pump would include, for example, an internal, electric pump; Patent Owner concludes that Pansini teaches away from Petitioner's proposed combination

Case IPR2013-00159  
Patent 8,273,183 B2

of Pansini and Myers. We disagree.

As noted above, a reference may be said to teach away when a person of ordinary skill, upon reading the reference, would be discouraged from following the path set out in the reference, or would be led in a direction divergent from the path that was taken by patentee. Here, Patent Owner provides no evidence supporting the contention that a booster pump is equivalent to an internal pump. Moreover, we are not persuaded that the Pansini's statement that "there is no *need* to employ a booster pump for proper operation of the cleaner" (Pansini, col. 1, ll. 38-43 (emphases added)) would discourage persons of ordinary skill in the relevant art from incorporating such a pump within the cleaner described in Pansini. Therefore, we are not persuaded that Pansini teaches away from the Petitioner's proposed combination of Pansini and Myers.

Second, Patent Owner contends that Petitioner fails to describe how an internal pump could be incorporated *operably* within Pansini's pool cleaner. Prelim. Resp. 25. In particular, Patent Owner contends that:

A person of ordinary skill in the art would not know how to install an internal electric pump within the confines of this filtering chamber or any other area of the Pansini cleaner without undue experimentation. In addition, such an installation would require the person skilled in the art to disregard the teaching of Myers that the pump is installed outside the filtration medium (Myers, FIG. 2).

Pet. 25. As the U.S. Supreme Court has explained, "if a technique has been used to improve one device, and a person of ordinary skill in the art would recognize that it



Case IPR2013-00159  
Patent 8,273,183 B2

would improve similar devices in the same way, using the technique is obvious unless its actual application is beyond his or her skill.” *KSR*, 550 U.S. at 417. Because Patent Owner does not demonstrate that the proposed combination would be beyond the skill of a person of ordinary skill in the relevant art, we are not persuaded by this contention.

Third, Patent Owner again contends that Petitioner fails to explain how the elimination of the supply hose “to prevent entanglement” would provide a reason to incorporate an internal pump when such an internal pump would require the addition of a power supply cable that also would be subject to entanglement. Prelim. Resp. 25-26. For the same reasons that we were not persuaded by these contentions with respect to the combination of Henkin and Myers, we not persuaded by the same contentions here with respect to the combination of Pansini and Myers.

Because Patent Owner contends that the reasons discussed above apply to independent claims 20 and 21, as well as independent claim 1 (Prelim. Resp. 26), we are persuaded that Petitioner has demonstrated a reasonable likelihood of prevailing on its challenge to the patentability of claims 20 and 21 of the ’183 Patent as unpatentable over Pansini and Myers. Patent Owner contends that Petitioner fails to demonstrate that there is a reasonable likelihood of prevailing on its challenge to the patentability of claims 2-9 and 19, which depend from independent claim 1, as unpatentable over Pansini and Myers, based solely on the alleged deficiencies in this combination of references with respect to claim 1. Prelim. Resp. 27. Therefore, in view of the foregoing discussion of claim 1, we also are persuaded that Petitioner has demonstrated a reasonable likelihood of prevailing on its challenge to the

Case IPR2013-00159  
Patent 8,273,183 B2

patentability of claims 2-9 and 19 of the '183 Patent as unpatentable over Pansini and Myers.

3. *Altschul and Myers*

Petitioner argues that Altschul discloses substantially all of the limitations of independent claim 1, except that Altschul discloses the use of an external pump, rather than an internal pump. Pet. 17-20. Myers, however, teaches the use of an internal pump, *e.g.*, ordinary rotary pump 23. Pet. 19-20. Petitioner argues that a person of ordinary skill in the relevant art would have had a reason to modify the teachings of Altschul to replace the external pump with an internally-mounted pump to eliminate the need (1) for an external source of pressurized water and supply hose, and (2) to manage the supply hose to prevent entanglement. *Id.* For the reasons set forth below, we disagree.

Patent Owner does not dispute Petitioner's reading of the limitations of claim 1 on the disclosure of Altschul. Instead, Patent Owner disagrees with Petitioner's combination of the teachings of Altschul with those of Myers. In particular, Patent Owner disputes the proposed combination of teachings for reasons similar to those discussed above with respect to the combinations of Henkin and Myers and of Pansini and Myers. Prelim. Resp. 27-34. We are not persuaded that Petitioner has demonstrated that it is reasonably likely to prevail on the issue of obviousness for claims 1-5, 7-12, and 19-21 of the '183 Patent based on Altschul and Myers.

Unlike the cleaning devices described Myers, Henkin, Pansini, and the '183 Patent, which are designed to clean the bottom surface of a pool or tank, Altschul describes a cleaning device "for cleaning the sidewalls of a swimming pool at the

Case IPR2013-00159  
 Patent 8,273,183 B2

waterline region, within a few inches above and below the waterline.” Prelim. Resp. 7 (quoting Altschul, col. 1, ll. 8-9).

Figure 1 of Altschul (Ex. 1004) is reproduced below:

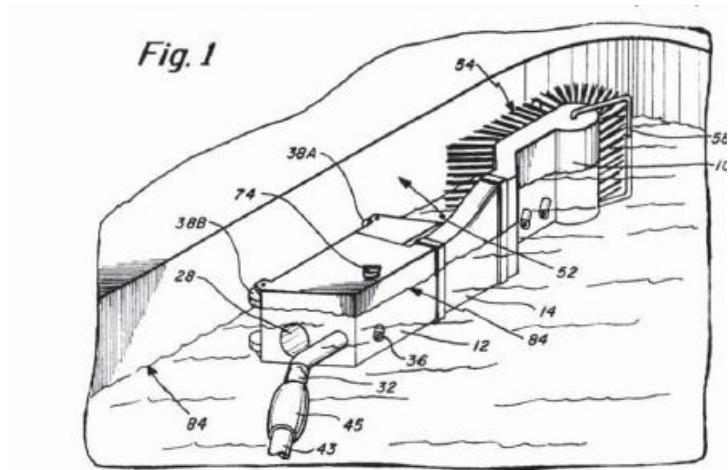


Figure 1 depicts Altschul’s device for cleaning a swimming pool sidewall, travelling along the sidewall in a partially-submerged condition.

In view of the stated purpose of cleaning immediately above and below the waterline, Altschul’s device “includes floatation material which affords sufficient buoyancy to maintain the device at the proper level in the water, about two to three inches above the waterline as it travels along the sidewalls.” Altschul, col. 2, ll. 18-22; *see* Prelim. Resp. 7, 27-28, 32-33. Despite the purpose of Altschul’s device and the need to maintain a specific degree of buoyancy to accomplish this purpose, Petitioner proposes modifying Altschul’s device to include an internal water pump, instead of an external water pump. Pet. 19-20. Patent Owner notes that “[t]he Petitioner, Myers and Altschul all give no guidance about . . . *how the weight of an electric pump might affect buoyancy.*” Prelim. Resp. 32-33 (emphasis added). Although Petitioner identifies a reason allegedly supporting the proposed

Case IPR2013-00159  
Patent 8,273,183 B2

modification, Petitioner does not address the inconsistency or conflict created by the proposed modification or to explain why, on balance, the benefits of the proposed modification outweigh its deleterious effects on the operation and use of Altschul's device. *See Winner Int'l Royalty Corp.*, 202 F.3d at 1349, n.8 (“the benefits, both lost and gained, [by the proposed combination] should be weighed against one another”); *see also, DuPuy Spine, Inc. v. Medtronic Sofamor Danek, Inc.*, 567 F.3d 1314, 1326-27 (Fed. Cir. 2009) (different intended purpose may result in a reference teaching away from its combination with another reference). Because of these deficiencies in Petitioner's arguments, we are not persuaded that Petitioner has demonstrated a reasonable likelihood of prevailing on its challenge to the patentability of claims 1, 20, and 21 of the '183 Patent as unpatentable over Altschul and Myers or of claims 2-5, 7-12, and 19, which depend from independent claim 1. *See* Prelim. Resp. 33-34.

## V. CONCLUSION

For the foregoing reasons, we determine that Petitioner has demonstrated that there is a reasonable likelihood of prevailing on its challenge to the patentability of claims 1-9, 13, 14, 16, and 19-21 of the '183 Patent.

## VI. ORDER

For the reasons given, it is

**ORDERED** that the petition is granted as to claims 1-9, 13, 14, 16, and 19-21 of the '183 Patent and that, pursuant to 35 U.S.C. § 314, an *inter partes* review of the '183 Patent is hereby instituted for the following grounds:

Case IPR2013-00159  
Patent 8,273,183 B2

1. Claims 1, 2, 13, 14, 16, and 19-21 under 35 U.S.C. § 102(b) as anticipated by Myers;
2. Claims 1-5 and 19-21 under 35 U.S.C. § 103(a) as unpatentable over Henkin and Myers; and
3. Claims 1-9 and 19-21 under 35 U.S.C. § 103(a) as unpatentable over Pansini and Myers.

**FURTHER ORDERED** that the Petition for *inter partes* review based on the following grounds is denied:

Claims 1-5, 7-12, and 19-21 under 35 U.S.C. § 103(a) as unpatentable over Altschul and Myers.

**FURTHER ORDERED** that pursuant to 35 U.S.C. § 314(a), *inter partes* review of the '183 Patent is hereby instituted commencing on the entry date of this Order, and, pursuant to 35 U.S.C. § 314(c) and 37 C.F.R. § 42.4, notice is hereby given of the institution of a trial.

**FURTHER ORDERED** that the trial is limited to anticipation by Myers and to obviousness over Henkin and Myers or over Pansini and Myers; and no other grounds are authorized.

**FURTHER ORDERED** that an initial conference call with the Board is scheduled for 2:00 PM EDT on September 24, 2013. The parties are directed to the Office Trial Practice Guide, 77 Fed. Reg. 48756, 48765-66 (Aug. 14, 2012) for guidance in preparing for the initial conference call, and should come prepared to discuss any proposed changes to the Scheduling Order entered herewith and any motions the parties anticipate filing during the trial.

Case IPR2013-00159  
Patent 8,273,183 B2

PETITIONER:

John A. Hankins  
Eric R. Garcia  
McDERMOTT, WILL & EMERY LLP  
[jhankins@mwe.com](mailto:jhankins@mwe.com)  
[ergarcia@mwe.com](mailto:ergarcia@mwe.com)

PATENT OWNER:

Jeffrey A. Schwab  
Richard L. Crisona  
ABELMAN, FRAYNE & SCHWAB  
[jaschwab@lawabel.com](mailto:jaschwab@lawabel.com)  
[rlcrisona@lawabel.com](mailto:rlcrisona@lawabel.com)

cu

**UNITED STATES COURT OF APPEALS  
FOR THE FEDERAL CIRCUIT**

**AQUA PRODUCTS, INC.  
Patent Owner/Appellant**

**v.**

**ZODIAC POOL SYSTEMS, INC.  
Requester/Appellee**

**Proceeding No: IPR2013-00159**

**NOTICE FORWARDING CERTIFIED LIST**

A Notice of Appeal to the United States Court of Appeals for the Federal Circuit was timely filed October 23, 2014, in the United States Patent and Trademark Office in connection with the above identified *Inter Partes Review* proceeding. Pursuant to 35 U.S.C. § 143 a Certified List is this day being forwarded to the Federal Circuit.

Respectfully submitted,

Under Secretary of Commerce for Intellectual  
Property and Director of the United States  
Patent and Trademark Office

By: 

Kyra Abraham  
Paralegal  
Mail Stop 8  
P.O. Box 1450  
Alexandria, VA 22313-1450  
571-272-9035

Date: December 3, 2014

**CERTIFICATE OF SERVICE**


The undersigned hereby certifies that a true and correct copy of the foregoing has been served on Appellant and Appellee this 3<sup>rd</sup> day of December, 2014, as follows:

PETITIONER:

Christopher Bright  
Gregory Yoder  
Mark Bentley  
McDERMOTT, WILL & EMERY LLP  
[cbright@mwe.com](mailto:cbright@mwe.com)  
[gyoder@mwe.com](mailto:gyoder@mwe.com)  
[mbentley@mwe.com](mailto:mbentley@mwe.com)

PATENT OWNER:

Jeffrey A. Schwab  
Anthony Coppola  
ABELMAN, FRAYNE & SCHWAB  
[jaschwab@lawabel.com](mailto:jaschwab@lawabel.com)  
[aacoppola@lawabel.com](mailto:aacoppola@lawabel.com)

By:   
Kyra Abraham  
Paralegal  
Mail Stop 8  
P.O. Box 1450  
Alexandria, VA 22313-1450  
571-272-9035



**U.S. DEPARTMENT OF COMMERCE  
United States Patent and Trademark Office**

**December 3, 2014**

(Date)

**THIS IS TO CERTIFY** that the attached document is a list of the papers that comprise the record before the Patent Trial and Appeal Board (PTAB) for the *Inter Partes Review* proceeding identified below.

**ZODIAC POOL SYSTEMS, INC.**

**Petitioner**

**v.**

**AQUA PRODUCTS, INC.**

**Patent Owner**

**Case: IPR2013-00159**

**Patent No. 8,273,183 B2**

By authority of the

**DIRECTOR OF THE UNITED STATES  
PATENT AND TRADEMARK OFFICE**

*Kyra Abraham*

*Certifying Officer*



**Prosecution History IPR2013-00159**

<b>Date</b>	<b>Document</b>
2/25/2013	Petition for Inter Partes Review
2/25/2013	Petitioner's Power of Attorney
2/28/2013	Notice of Filing Date Accorded to Petition
3/1/2013	Response to Notice of Filing Date Accorded to Petition
3/5/2013	Notice of Accepting Corrected Petition
3/18/2013	Patent Owner Power of Attorney
3/18/2013	Related Matters
3/18/2013	Patent Owner's Required Notices
5/28/2013	Patent Owner's Preliminary Response
8/23/2013	Decision - Institution of Inter Partes Review
8/23/2013	Order - Scheduling Order
9/20/2013	Patent Owner's List of Anticipated Motions
9/26/2013	Order - Conduct of the Proceeding
10/2/2013	Patent Owner's Motion for Additional Discovery
10/9/2013	Opposition to Motion for Additional Discovery
10/18/2013	Decision - Motion for Additional Discovery
11/25/2013	Patent Owner's Motion to Amend Claims
11/25/2013	Patent Owner's Response to Petition
11/25/2013	Patent Owner's Appendix of Newly Filed Exhibits
12/27/2013	Patent Owner's Power of Attorney
2/3/2014	Petitioner's Power of Attorney
2/3/2014	Petitioner's Power of Attorney
2/3/2014	Notice of Deposition - Erlich
2/10/2014	Joint Stipulation to Modify Scheduling Order
2/11/2014	Patent Owner's Power of Attorney
2/11/2014	Patent Owner's Amended Mandatory Notices
2/14/2014	Order - Authorization to File Corrected Motion to Amend
2/18/2014	Patent Owner's Corrected Motion to Amend Claims
2/26/2014	Order - Requiring Filing of Replacement, Corrected Motion to Amend, Expunging Exhibits and Requiring Refiling of Corrected Declaration
3/3/2014	Joint Stipulation
3/3/2014	Patent Owner's Replacement Corrected Motion to Amend Claims
3/3/2014	Patent Owner's Current Exhibit List
3/10/2014	Reply to Response to Petition For Inter Partes Review
3/10/2014	Opposition to Replacement Corrected Motion to Amend Claims
3/10/2014	Petitioner's Revised Appendix of Exhibits
3/18/2014	Notice of Deposition - Kazerooni
3/18/2014	Notice of Deposition - McQueen
3/20/2014	Joint Motion to Amend Scheduling Order
3/21/2014	Standing Protective Order

**Prosecution History IPR2013-00159**

<b>Date</b>	<b>Document</b>
3/28/2014	Decision - Authorizing Patent Owner to File Supplemental Information and Granting Joint Motion to Amend The Scheduling Order - Conduct of the Proceeding
4/8/2014	Patent Owner's Reply In Support of Motion to Amend Claims
4/8/2014	Patent Owner's Sur Reply to Petition for Inter Partes Review
4/11/2014	Patent Owner's Exhibit List
4/15/2014	Corrected Reply in Support of Motion to Amend
4/15/2014	Patent Owner's Corrected Sur Reply to Petition for Inter Partes Review
4/18/2014	Patent Owner's Request for Oral Argument
4/18/2014	Patent Owner's Motion to Exclude Evidence
4/18/2014	Petitioner's Request for Oral Argument
4/29/2014	Order - Trial Hearing
5/2/2014	Opposition to Motion to Exclude Evidence
5/8/2014	Patent Owner's Reply Memorandum in Support of Its Motion to Exclude Evidence
5/13/2014	Patent Owner's Submission of Demonstrative Exhibits
5/13/2014	Petitioner's Notice of Change of Counsel
5/13/2014	Petitioner's Submission of Demonstratives
5/14/2014	Order - Confirmation of Petitioner's Trial Hearing Counsel
5/15/2014	Patent Owner's Notice of Change of Back-up Counsel
5/16/2014	Order - Conduct of the Proceeding
8/4/2014	Record of Oral Hearing
8/22/2014	Final Written Decision

Case Nos. IPR2013-00159

Patent Nos. 8,273,183

1 MR. BRIGHT: Can I just very quickly lodge an objection  
2 as to a new argument with respect to removal of the hose and how that  
3 contributes to the erratic behavior in Myers? I didn't address that.

4 JUDGE MCNAMARA: So noted. Please, hold it until  
5 rebuttal.

6 MR. BRIGHT: Thank you.

7 MR. SCHWAB: What I am trying to articulate, maybe in  
8 an inappropriate fashion, but let me say it more bluntly: We have  
9 stated in our papers, we have provided not attorney rhetoric or  
10 argument, but an affidavit by someone who has defined the person of  
11 ordinary skill in the art and has said, I've read the Board's decision,  
12 and as I understand the meaning of the specification in the Board's  
13 decision, I, a person of ordinary skill in the art, believe that front,  
14 forward and discharge are related, structurally related.

15 Now, I don't know, other than attorney argument, what the  
16 other side has put out or offered. They've offered zero on the issue of  
17 a person of ordinary skill in the art. They haven't defined it. They  
18 haven't accepted our definition. Unlike what I would consider patent  
19 office prosecution, going and sitting down with the examiner, and  
20 we're negotiating this, this is an evidentiary hearing. This is a trial.

21 What is on the record? What I heard from counsel was,  
22 well, it's self-evident, and if anyone could logically reach the  
23 conclusion we've reached, that's enough. I don't believe that to be the  
24 case. If one side puts forward a statement by a person of ordinary  
25 skill -- and it's not as if the other side didn't have an opportunity.

Case Nos. IPR2013-00159

Patent Nos. 8,273,183

1 All right. 2004 comes along. McQueen says, we are going  
2 to go into a truly robotic unit, so what do they bring out? The Indigo.  
3 Mr. McQueen would have this Board believe, and you'll read his  
4 declaration, that this is a precursor to their angle jet drive, the one we  
5 say they copied, and they say they didn't.

6 What you're looking at is a copy, but it's a copy of our  
7 Aquabot, not our predecessor unit. It has a drive motor. It has a  
8 vertically-oriented pump. There is no angularity to that pump other  
9 than perpendicular. In other words, there's a drive motor. It is the  
10 prior art that we said was terrible, that drive, was giving us problems.  
11 It can't be terrible, it was one of our key products, but was giving us  
12 major headaches.

13 So what happened? According to Mr. McQueen they were  
14 having major headaches. They pulled it off the market, electrical  
15 problems, not atypical to what Mr. Erlich said were all these  
16 problems. This is a difficult unit. So they, what? They had Henkin.  
17 Why didn't they just do it? It was so obvious.

18 Again it's not some stranger here. This is someone who  
19 owned Henkin, who built the Henkin equipment. There is zero  
20 recognition that they could get rid of the drive motor and put in a  
21 pump. In fact, if you look again at Henkin, you will see that the pump  
22 doesn't -- his little nozzle 90 does not deal with filtered water.

23 What does that tell you? It is taking a sidetracking -- I'm  
24 sorry, I put it away. I was referring to our page 4 for the record, a  
25 sidetrack, a small Venturi sidetrack, not in a way in which the filtered

Case Nos. IPR2013-00159

Patent Nos. 8,273,183

1 water -- when I tell you're using filter water, I'm telling you you're  
2 using the main suction of the unit.

3           So now comes 2007. Mr. McQueen says to us -- again I  
4 have a lot of problems with even referencing these because I don't  
5 think it's -- his declaration should be accepted at all, but he does say  
6 this: we then decided to really go for an angle drive, so what do we  
7 do? We went and got a study, an engineering study. It's in French. It  
8 was partially given to us. It wasn't even given to the Court or to the  
9 Board, but basically he said they were checking flows. They were  
10 looking at stuff.

11           What does that mean? It means that they needed to do  
12 some investigation. Why should they? They had Henkin. Baloney.  
13 Henkin taught them nothing in terms of the kind of drive that we  
14 claim -- we claim in Claim 21 and frankly in the amended claims.

15           So what happens? 2008 they come back to us and talk  
16 about a joint venture. Now, Mr. McQueen says, well, we weren't  
17 really interested. However, they are working on, by Mr. McQueen's  
18 declaration, a device supposedly on an angle drive. They have no  
19 interest in us, but, in 2008, they fly two of their major executives  
20 across country to take one more look at our technology.

21           I suggest to you that on the factual record with the person of  
22 most great interest and knowledge of Henkin, it is and cannot be made  
23 obvious. It is and cannot be combined with Myers. It's totally  
24 different in terms of its concept, and it is simply not an appropriate  
25 reference to find that Claim 21 or any of the claims are unpatentable,

Case Nos. IPR2013-00159

Patent Nos. 8,273,183

1 alone, in combination or other otherwise, and it is really the horse  
2 they're riding. I understand Myers because of the language issue, but  
3 Henkin is the horse they're riding in terms of the technology issue.  
4 The fact is there is no recognition.

5 I last --

6 JUDGE ARPIN: Counsel, can we turn to the claim  
7 language for a moment? In the second to the last step of Claim 21, it  
8 says discharging the filtered water through the directional discharge  
9 conduit at an acute angle with respect to the surface over which the  
10 apparatus is moving, said discharge filtered water forming a water jet  
11 having resultant force vector acutely angled toward the surface  
12 beneath the apparatus.

13 Now, we've been pointing to language in Henkin that says  
14 that the nozzle 90 is selected to yield, I assume that means the variable  
15 or the adjustable aspect of it -- yield both a downward thrust  
16 component, i.e., normal to the rest of the surface for providing  
17 traction, and also in your response you have stated that with respect to  
18 Henkin -- I'm trying to find the quote here, "[s]ome small amount of  
19 water pressure, which provides for a minimal amount of resistance of  
20 motion and/or surface contact is provided by nozzle 90." This was  
21 paper 28, page 6.

22 I'm having a hard time finding why Henkin doesn't show  
23 this downward force at an acute angle.

24 MR. SCHWAB: I will say this: Henkin, without question,  
25 uses the words in the patent and in the drawing that says, if you have

Case Nos. IPR2013-00159

Patent Nos. 8,273,183

1 MR. SCHWAB: All right. Clearly, I'll just say that Pansini  
2 has a force that is supposed to counter the force of the hose behind it,  
3 so that the thing doesn't tilt, and that's really the practical aspects of  
4 Pansini.

5 Let's get to the amendment, if I could, if you give me a  
6 second.

7 JUDGE MCNAMARA: You can use your entire 60  
8 minutes if you want at this point.

9 MR. SCHWAB: No. Look, I believe that the issues  
10 regarding the amended claims are more procedural than substantive  
11 because the arguments about the prior art only get better with the fact  
12 of the amendment.

13 JUDGE MCNAMARA: As I said, it's argument to do with  
14 as you wish, so allocate your time as you choose. I just wanted to  
15 give you a heads up.

16 MR. SCHWAB: Okay. Thank you. It's amazing when you  
17 have to cut to the chase, isn't it?

18 The amended claims are permissible. They do not suffer  
19 from any infirmities, and they're patentable.

20 As I preface, I just want to structure those claims. Without  
21 going into the words, if I had more time, we would put them up, and I  
22 would go over it, but let me tell you how the claims changed. We  
23 took Claim 1. We use that as a basic, and we now precisely define a  
24 front, so we now longer have this varying front because they're



Case Nos. IPR2013-00159

Patent Nos. 8,273,183

1 actually located rotational supports, approximate to front in the rear. I  
2 create a geometry. The claim does.

3 We provide that these supports or wheels control the  
4 directional movement and require that the water jet has a resultant  
5 force vector that has a direct relationship to the position that is  
6 proximate to and rearward of a line passing through the transverse  
7 mounting.

8 The patent owner has to demonstrate patentability, I agree.  
9 The early declaration provides the Board with the requisite  
10 information to consider the claims. The Erlich declaration discusses  
11 the general level of skill in the art and goes beyond and provides this  
12 Board with references, additional to the references of record, and what  
13 he knew about and stated that this is the maximum that not only was  
14 he aware of, but he was aware of in a general sense in the state of the  
15 art.

16 He gave the details of the patentable distinctions over the  
17 art, and he explains why a person of ordinary skill had not previously  
18 considered the problems, sought out the solutions or provided the  
19 general techniques to solve those problems.

20 In other words, the threshold that this tribunal has set  
21 forward as to, are you entitled to even talk about amending claims, has  
22 been more than satisfied.

23 For the purposes of support, I would like to go over the  
24 genesis of Claim 22. As the Board is aware, they did not institute this  
25 proceeding with regard to Claim 10, and I'll walk you through this,

Case Nos. IPR2013-00159

Patent Nos. 8,273,183

1           Then we said that the wheels are the guiding elements to  
2 control the direction of movement, and this Board has decided -- I'm  
3 sorry, withdrawn, the direction of motion.

4           Petitioner argues that there's a difference between Claim 11  
5 and Claim 22 because 11 describes the force vector with respect to  
6 discharge conduit, and proposed Claim 22 has an inclined angle with  
7 respect to the surface beneath the apparatus.

8           Geometrically, now that we've defined the four corners and  
9 a true front and rear that's a difference without a distinction, and if you  
10 look at Claims 3 and 19, which although under rejection because they  
11 didn't define wheels, expressed that very same concept.

12           Petitioner then argues that to control the direction of  
13 movement is broader than the word construct, which was enabled.  
14 Petitioner is wrong. Limitation to the claim is not the control  
15 movement. It is to control directional movement. This is more  
16 limiting in my judgment, in English or otherwise. I enable something.  
17 If I control its direction, enable means to get it to go. All I'm saying is  
18 I'm telling you where -- its direction. It is a more limiting  
19 amendment, not a broadening.

20           Indeed as we saw, the angular brushes of Myers enable  
21 erratic motion, but don't control directional motion.

22           JUDGE MCNAMARA: Counsel, just a reminder, that was  
23 the 40 minute mark, so feel free to continue.

24           MR. SCHWAB: Then I'm going to take another three or  
25 four, and then frankly reserve on Claim 23 because 24 is substantially

Case Nos. IPR2013-00159

Patent Nos. 8,273,183

1 22. It's with some additional limitations. 23 has another technical  
2 objection.

3 But it's clear now in Claim 22, and this Board has already  
4 made a generalized -- has a generalized view of the patentability, that  
5 where you have rotationally mounted axially mounted supports,  
6 transverse and located in fronts and the rear and a discharge is as we  
7 have now phrased it, that the prior art raised and the prior art we made  
8 this Board aware of -- in addition to the prior art raised, the true state  
9 of the art permits this Board to accept the amendment and find the  
10 claims patentable.

11 There is a technical issue regarding the definition of the  
12 word plane with regard to Claim 23, but I would like to reserve my  
13 time, if the Board is interested in the in limine, it's very simple. If you  
14 put in an affidavit or a declaration that doesn't define a person of  
15 ordinary skill in the art, it is worthless.

16 JUDGE MCNAMARA: Counsel, you will have 19 minutes  
17 left.

18 MR. SCHWAB: Thank you.

19 MR. BRIGHT: Let me, if I may, Your Honors, just lodge  
20 an objection to the argument that I heard during the patent owner's  
21 presentation, that the removal of the hose in Myers actually  
22 contributes to the erratic movement in Myers. Unless I'm missing  
23 something, I did not see that argument made in the record. I certainly  
24 saw lots of argumentation about the erratic movement of Myers, but I

Case Nos. IPR2013-00159

Patent Nos. 8,273,183

1 did not see the argument that a removal of the hose contributes to the  
2 erratic movement in Myers.

3 The presentation by the patent owner was interesting in this  
4 respect. Most of it was spent talking about the history between the  
5 parties as recounted from the perspective of Mr. Erlich, who, let's not  
6 forget, has an interest in the outcome in these proceedings.

7 With respect to the 2002 meeting, there's absolutely no  
8 corroboration whatsoever of Mr. Erlich's statements about who said  
9 what, what documentation was provided and what was discussed and  
10 what the reactions were of the people at that meeting in 2002, and it's  
11 interesting -- so 2002.

12 Then it's another five or six years before the parties  
13 purportedly -- that they meet again, and yet somehow this idea that  
14 Mr. Erlich presented in 2002 was so revolutionary, so interesting, that  
15 the predecessors -- that the petitioner didn't do anything, didn't do  
16 anything in 2003 to contact Mr. Erlich, to meet with him again in  
17 2004, 2005, 2006. And then they meet again in 2008.

18 It had been years, if the idea was so revolutionary in 2002,  
19 it just defies common sense that years go by with no interest in it, in  
20 the technology, in what Mr. Erlich had to sell according to him in  
21 2002.

22 I also find it interesting that most of the patent owner's  
23 presentation was not spent on the actual language of Claim 21. It was  
24 spent on these other things. The patent owner, when addressing

Case Nos. IPR2013-00159

Patent Nos. 8,273,183

1 Another issue raised by the patent owner was on slide 6 of  
2 its presentation, and there was mention of the Indigo cleaner. This  
3 was one of a line of cleaners in the Zodiac portfolio. There was  
4 mention of Mr. McQueen's declaration and how he says that they had  
5 their own robotic cleaner on sale in the United States so they were  
6 aware of jet propulsion technology.

7 Now, there were other cleaners on the market as well.  
8 What Mr. McQueen was recognizing was we were aware of market  
9 conditions, and as acknowledged by the patent owner, there was the  
10 cleaner that was consistent with the Henkin design that included this  
11 nozzle 90 with the propulsive jet force, for an example.

12 Just going through my notes of arguments that were raised  
13 in the patent owner's presentation, I would like to also lodge an  
14 objection that the argument that we heard by patent owner that there  
15 would not be a reason to find Henkin -- to combine the prior art, was  
16 because we had our own commercial embodiments purportedly of  
17 Henkin on the market and didn't combine them, and I don't believe, as  
18 I recall, if memory serves, that that argument was made in the  
19 briefing.

20 On the motion to amend -- I'll turn to that now in my time  
21 remaining. On the motion to amend, I would like to point out that  
22 even by the time we get to the end of the briefing on the motion to  
23 amend from the patent owner and looking even at the patent owner's  
24 motion, there were no definitions set forth, terms like transverse. We  
25 raised this as an issue in our opposition, that the patent owner did not

Case Nos. IPR2013-00159

Patent Nos. 8,273,183

1 a longitudinal axis of said apparatus, we don't explicitly known from  
2 patent owner, but if it's -- if it's construed this way, that it's -- that the  
3 axes of rotation of the supports simply have to cross over the  
4 longitudinal axis of the apparatus, it's met in Myers. That limitation is  
5 met.

6 So what are we left with? We're left on these proposed  
7 substitute claims, the fact that they've added wheels, and we see  
8 wheels in Henkin. We see wheels in Pansini. The motivation to  
9 combine them still applies, as was recognized in the Board's decision,  
10 that a person of ordinary skill in the art would be motivated to take the  
11 internal pump mechanism of Myers and apply it to -- and apply it to  
12 Henkin and Myers, and there's plenty of --

13 JUDGE ARPIN: Counselor, does it matter that Henkin and  
14 Pansini are three-wheeled devices and at least in Claim 23 of the  
15 substitute claim, patent owner is talking about first and second pairs of  
16 wheels?

17 MR. BRIGHT: It matters from the perspective of what's the  
18 mechanism for invalidity in the sense that there certainly still would  
19 be obviousness here. Even though Myers doesn't disclose two sets of  
20 wheels, even though Henkin doesn't disclose two sets of wheels, we  
21 have two sets of wheels in Pansini. We have a recognition in all this  
22 prior art that there's not only a desire to have a resultant force vector  
23 that provides a propulsive force, hold down force, and to do so in the  
24 right angular relationship as disclosed in Myers.

**IN THE UNITED STATES PATENT AND TRADEMARK OFFICE**

In the *Inter Partes* Review of:

U.S. Patent No. 8,273,183

Filed: July 12, 2011

Issued: September 25, 2012

Inventors: Giora Erlich et al.

Assignee: Aqua Products, Inc.

For: AUTOMATED SWIMMING POOL CLEANER  
HAVING AN ANGLED JET DRIVE  
PROPULSION SYSTEM

Attorney Docket No.: 084586-0208

Trial Number: To Be Assigned

Panel: To Be Assigned

Mail Stop *Inter Partes* Review  
Commissioner for Patents  
P.O. Box 1450  
Alexandria, VA 22313-1450

**PETITION FOR *INTER PARTES* REVIEW UNDER 37 C.F.R. § 42.100**

**TABLE OF CONTENTS**

**I. MANDATORY NOTICES UNDER 37 C.F.R. § 42.8(a)(1)**..... 1

**A. Real Party-In-Interest Under 37 C.F.R. § 42.8(b)(1)**..... 1

**B. Related Matters Under 37 C.F.R. § 42.8(b)(2)**..... 1

**C. Lead and Back-Up Counsel Under 37 C.F.R. § 42.8(b)(3)**..... 1

**D. Service Information Under 37 C.F.R. § 42.8(b)(4)** ..... 1

**II. PAYMENT OF FEES UNDER 37 C.F.R. § 42.103** ..... 2

**III. REQUIREMENTS FOR *INTER PARTES* REVIEW UNDER 37 C.F.R. § 42.104** ..... 2

**A. Grounds for Standing Under 37 C.F.R. § 42.104 (a)**..... 2

**B. Identification of Challenge Under 37 C.F.R. §§ 42.104(b) and Relief Requested** ..... 2

        1. *Claims for Which Inter Partes Review is Requested Under 37 C.F.R. § 42.104(b)(1)* ... 2

        2. *The Specific Art and Statutory Ground(s) on Which the Challenge Is Based Under 37 C.F.R. § 42.104(b)(2)*..... 2

        3. *How the Challenged Claim(s) Are to Be Construed Under 37 C.F.R. § 42.104(b)(3)* .... 4

**IV. SUMMARY OF THE ‘183 PATENT** ..... 5

**A. Description of the Alleged Invention of the ‘183 Patent**..... 5

**B. Summary of the Prosecution History of the ‘183 Patent**..... 5

**V. THERE IS A REASONABLE LIKELIHOOD THAT AT LEAST ONE CLAIM OF THE ‘183 PATENT IS UNPATENTABLE UNDER 37 C.F.R. § 42.104(b)(4)**..... 6

**A. Identification of the References as Prior Art**..... 6

**B. Summary of Invalidity Arguments** ..... 7

**VI. DETAILED EXPLANATION UNDER 37 C.F.R. §§ 42.104(b)**..... 7



**A. Claim 1 (Independent)**..... 7

**B. Claim 2 (Dependent)**..... 21

**C. Claim 3 (Dependent)**..... 22

**D. Claim 4 (Dependent)**..... 26

**E. Claim 5 (Dependent)**..... 29

**F. Claim 6 (Dependent)**..... 31

**G. Claim 7 (Dependent)**..... 32

**H. Claim 8 (Dependent)**..... 34

**I. Claim 9 (Dependent)**..... 35

**J. Claim 10 (Dependent)**..... 37

**K. Claim 11 (Dependent)**..... 38

**L. Claim 12 (Dependent)**..... 39

**M. Claim 13 (Dependent)**..... 40

**N. Claim 14 (Dependent)**..... 40

**O. Claim 16 (Dependent)**..... 41

**P. Claim 19 (Dependent)**..... 41

**Q. Claim 20 (Independent)**..... 45

**R. Claim 21 (Independent)**..... 52

**VII. CONCLUSION**..... 60

On behalf of Zodiac Pool Systems, Inc. (“Zodiac”) and in accordance with 35 U.S.C. § 311 and 37 C.F.R. C 42.100, *inter partes* review is respectfully requested for claims 1-14, 16, and 19-21 of U.S. Patent No. 8,273,183 (“the ’183 patent”).

**I. MANDATORY NOTICES UNDER 37 C.F.R. § 42.8(a)(1)**

As set forth below and pursuant to 37 C.F.R. § 42.8(a)(1), the following mandatory notices are provided as part of this Petition.

**A. Real Party-In-Interest Under 37 C.F.R. § 42.8(b)(1)**

Zodiac Pool Systems, Inc. is the real party-in-interest for Petitioner.

**B. Related Matters Under 37 C.F.R. § 42.8(b)(2)**

The ’183 patent is presently the subject of a patent infringement lawsuit by the assignee, Aqua Products, Inc., against Zodiac Pool Systems, Inc., captioned *Aqua Products, Inc. v. Zodiac Pool Systems, Inc.*, filed in the USDC Southern District of New York, Case No.: 12 CIV 9342.

**C. Lead and Back-Up Counsel Under 37 C.F.R. § 42.8(b)(3)**

Pursuant to 37 C.F.R. §§ 42.8(b)(3) and 42.10(a), Petitioner provides the following designation of counsel.

Lead Counsel	Back-Up Counsel
John A. Hankins (Reg. No. 32,029) jhankins@mwe.com <u>Postal and Hand-Delivery Address:</u> McDermott Will & Emery LLP 4 Park Plaza, Suite 1700 Irvine, California 92614-2559 Telephone: (949) 851-0633 Fax: (949) 851-9348	Eric R. Garcia (Reg. No. 69,630) ergarcia@mwe.com <u>Postal and Hand-Delivery Address:</u> McDermott Will & Emery LLP 4 Park Plaza, Suite 1700 Irvine, California 92614-2559 Telephone: (949) 851-0633 Fax: (949) 851-9348

Pursuant to 37 C.F.R. § 41.10(b), a Power of Attorney accompanies this Petition.

**D. Service Information Under 37 C.F.R. § 42.8(b)(4)**

Service information for lead and back-up counsel is provided in the designation of lead and back-up counsel, above. Service of any documents via hand-delivery may be made at the postal mailing address of the respective lead or back-up counsel designated above.

**II. PAYMENT OF FEES UNDER 37 C.F.R. § 42.103**

The undersigned authorizes the Office to charge \$27,200 to Deposit Account No. 502624 for the fees set forth in 37 C.F.R. § 42.15(a) for this Petition for *Inter Partes* Review. Eighteen claims are being reviewed, so no excess claim fees are required. The undersigned further authorizes payment for any additional fees that might be due in connection with this Petition to be charged to the above-referenced Deposit Account.

**III. REQUIREMENTS FOR *INTER PARTES* REVIEW UNDER 37 C.F.R. § 42.104**

As set forth below and pursuant to 37 C.F.R. § 42.104, each requirement for *inter partes* review of the '183 patent is satisfied.

**A. Grounds for Standing Under 37 C.F.R. § 42.104 (a)**

Petitioner hereby certifies that the '183 patent is available for *inter partes* review and that the Petitioner is not barred or estopped from requesting *inter partes* review challenging the claims of the '183 patent on the grounds identified herein. More particularly, Petitioner certifies that: [1] Petitioner is not the owner of the '183 patent; [2] Petitioner has not filed a civil action challenging the validity of a claim of the '183 patent; [3] this Petition is filed less than one year after the date on which the Petitioner, the Petitioner's real party-in-interest, or a privy of the Petitioner was served with a complaint alleging infringement of the '183 patent; and [4] the estoppel provisions of 35 U.S.C. § 315(e)(1) do not prohibit this *inter partes* review.

**B. Identification of Challenge Under 37 C.F.R. §§ 42.104(b) and Relief Requested**

The precise relief requested by Petitioner is that claims 1-14, 16, and 19-21 of the '183 patent be found unpatentable.

**1. Claims for Which *Inter Partes* Review is Requested Under 37 C.F.R. § 42.104(b)(1)**

Petitioner requests *inter partes* review of claims 1-14, 16, and 19-21 of U.S. Patent No. 8,273,183.

**2. The Specific Art and Statutory Ground(s) on Which the Challenge Is Based Under 37 C.F.R. § 42.104(b)(2)**

*Inter partes* review of the '183 patent is requested in view of the following references: [1] U.S. Patent No. 3,321,787 to Myers ("Myers"); [2] U.S. Patent No. 3,936,899 to Henkin et al.

Petition for *Inter Partes* Review of U.S. Patent No. 8,273,183

Attorney Docket No.: 084586-0208

(“Henkin”); [3] U.S. Patent No. 4,100,641 to Pansini (“Pansini”); and [4] U.S. Patent No. 4,429,429 to Altschul (“Altschul”).

Each of the patents listed above is prior art to the ’183 patent under 35 U.S.C. §§ 102(a), (b), and/or (e), as established in Section V(A), below.

<b>Claim No.</b>	<b>Proposed Statutory Rejections for the ‘183 Patent</b>
<b>1</b>	Claim 1 is <b>anticipated</b> under § 102(b) by Myers
<b>1</b>	Claim 1 is <b>obvious</b> under § 103(a) over Henkin in view of Myers
<b>1</b>	Claim 1 is <b>obvious</b> under § 103(a) over Pansini in view of Myers
<b>1</b>	Claim 1 is <b>obvious</b> under § 103(a) over Altschul in view of Myers
<b>2</b>	Claim 2 is <b>anticipated</b> under § 102(b) by Myers
<b>2</b>	Claim 2 is <b>obvious</b> under § 103(a) over Henkin in view of Myers
<b>2</b>	Claim 2 is <b>obvious</b> under § 103(a) over Pansini in view of Myers
<b>2</b>	Claim 2 is <b>obvious</b> under § 103(a) over Altschul in view of Myers
<b>3</b>	Claim 3 is <b>anticipated</b> under § 102(b) by Myers
<b>3</b>	Claim 3 is <b>obvious</b> under § 103(a) over Henkin in view of Myers
<b>3</b>	Claim 3 is <b>obvious</b> under § 103(a) over Pansini in view of Myers
<b>3</b>	Claim 3 is <b>obvious</b> under § 103(a) over Altschul in view of Myers
<b>4</b>	Claim 4 is <b>anticipated</b> under § 102(b) by Myers
<b>4</b>	Claim 4 is <b>obvious</b> under § 103(a) over Henkin in view of Myers
<b>4</b>	Claim 4 is <b>obvious</b> under § 103(a) over Pansini in view of Myers
<b>4</b>	Claim 4 is <b>obvious</b> under § 103(a) over Altschul in view of Myers
<b>5</b>	Claim 5 is <b>obvious</b> under § 103(a) over Henkin in view of Myers
<b>5</b>	Claim 5 is <b>obvious</b> under § 103(a) over Pansini in view of Myers
<b>5</b>	Claim 5 is <b>obvious</b> under § 103(a) over Altschul in view of Myers
<b>6</b>	Claim 6 is <b>obvious</b> under § 103(a) over Pansini in view of Myers
<b>7</b>	Claim 7 is <b>obvious</b> under § 103(a) over Pansini in view of Myers
<b>7</b>	Claim 7 is <b>obvious</b> under § 103(a) over Altschul in view of Myers
<b>8</b>	Claim 8 is <b>obvious</b> under § 103(a) over Pansini in view of Myers
<b>8</b>	Claim 8 is <b>obvious</b> under § 103(a) over Altschul in view of Myers

<b>Claim No.</b>	<b>Proposed Statutory Rejections for the '183 Patent</b>
<b>9</b>	Claim 9 is <b>obvious</b> under § 103(a) over Pansini in view of Myers
<b>9</b>	Claim 9 is <b>obvious</b> under § 103(a) over Altschul in view of Myers
<b>10</b>	Claim 10 is <b>obvious</b> under § 103(a) over Altschul in view of Myers
<b>11</b>	Claim 11 is <b>obvious</b> under § 103(a) over Altschul in view of Myers
<b>12</b>	Claim 12 is <b>obvious</b> under § 103(a) over Altschul in view of Myers
<b>13</b>	Claim 13 is <b>anticipated</b> under § 102(b) by Myers
<b>14</b>	Claim 14 is <b>anticipated</b> under § 102(b) by Myers
<b>16</b>	Claim 16 is <b>anticipated</b> under § 102(b) by Myers
<b>19</b>	Claim 19 is <b>anticipated</b> under § 102(b) by Myers
<b>19</b>	Claim 19 is <b>obvious</b> under § 103(a) over Henkin in view of Myers
<b>19</b>	Claim 19 is <b>obvious</b> under § 103(a) over Pansini in view of Myers
<b>19</b>	Claim 19 is <b>obvious</b> under § 103(a) over Altschul in view of Myers
<b>20</b>	Claim 20 is <b>anticipated</b> under § 102(b) by Myers
<b>20</b>	Claim 20 is <b>obvious</b> under § 103(a) over Henkin in view of Myers
<b>20</b>	Claim 20 is <b>obvious</b> under § 103(a) over Pansini in view of Myers
<b>20</b>	Claim 20 is <b>obvious</b> under § 103(a) over Altschul in view of Myers
<b>21</b>	Claim 21 is <b>anticipated</b> under § 102(b) by Myers
<b>21</b>	Claim 21 is <b>obvious</b> under § 103(a) over Henkin in view of Myers
<b>21</b>	Claim 21 is <b>obvious</b> under § 103(a) over Pansini in view of Myers
<b>21</b>	Claim 21 is <b>obvious</b> under § 103(a) over Altschul in view of Myers

**3. How the Challenged Claim(s) Are to Be Construed Under 37 C.F.R. § 42.104(b)(3)**

A claim subject to *inter partes* review receives the “broadest reasonable construction in light of the specification of the patent in which it appears.” 42 C.F.R. § 42.100(b). Petitioner submits, for the purposes of the *inter partes* review only, that the claim terms are presumed to take on their ordinary and customary meaning that the terms would have to one of ordinary skill in the art in view of the Specification of the '183 patent.

**4. *How the Construed Claim(s) Are Unpatentable Under 37 C.F.R. § 42.104(b)(4)***

An explanation of how construed claims 1-14, 16, and 19-21 of the '183 patent are unpatentable under the statutory grounds identified above, including the identification of where each element of the claim is found in the prior art patents or printed publications, is provided in Section VI, below, in the form of claims charts.

**5. *Supporting Evidence Under 37 C.F.R. § 42.104(b)(5)***

The exhibit numbers of the supporting evidence relied upon to support the challenge and the relevance of the evidence to the challenge raised, including identifying specific portions of the evidence that support the challenge, are provided in Section VI, below, in the form of claim charts. An Appendix of Exhibits identifying the exhibits is also attached.

**IV. SUMMARY OF THE '183 PATENT**

**A. Description of the Alleged Invention of the '183 Patent**

The '183 patent discloses a self propelled pool cleaner that uses a water jet for propulsion. The pool cleaner includes a housing, a water inlet disposed in a baseplate of the housing, and rotationally-mounted supports (wheels). A water pump is disposed within the housing and draws water through the inlet for filtering via a filter. The water drawn through the inlet is discharged through at least one discharge conduit in the form of a pressurized stream of water – forming a water jet. The discharge conduit is disposed at an acute angle with respect to the surface over which the cleaner moves. ('183 Patent, Abstract). This angle for the discharge conduit causes a resultant force that is directed downward, at an angle, toward the pool surface. (Col. 10, ll. 60-64).

**B. Summary of the Prosecution History of the '183 Patent**

The '183 patent was filed on July 12, 2011, and issued on September 25, 2012, with 21 claims, of which claims 1, 20 and 21 are independent. The '183 patent as filed included claims 1-24, of which claims 1, 19 and 20 were independent. The '183 patent claims priority to U.S. Patent No. 6,412,133, filed on January 25, 1999.

On January 17, 2012, in response to a Restriction Requirement, the Patent Owner argued that the pending claims, claims 1-24, “read on the embodiment shown by FIGS. 1-3, 8 and 9.” The

Examiner subsequently withdrew the Restriction Requirement. In addition, the Patent Owner characterized the claims as being directed to:

[A] pool cleaner apparatus [that] employs at least one discharge opening through which the water jet is directionally discharged from the cleaning apparatus at a predetermined angle that is less than normal with respect to the surface beneath the apparatus. At least one angled discharge outlet 120R and/or 120L extends from the jet valve assembly 40, as described in paragraphs 0091 through 0094 and shown in FIGS. 8 and 9 of the present application. Claims 1-24 recite limitations directed to the structural arrangement and operation of the angled discharge openings with respect to FIGS. 8 and 9 of the drawings.

(Ex. 1005 [Response to RR], p. 2). Thus, the Patent Owner limited the scope of the claims to the embodiment depicted in Figures 1-3, 8 and 9.

A non-final Office Action was mailed on March 12, 2012, allowing claims 1-20 and rejecting claims 21-24. In response to the non-final Office Action, an Amendment was filed on May 31, 2012, amending claims 3 and 20, canceling claims 21-24, and adding claim 25.

A Notice of Allowance dated July 24, 2012, was mailed in response to the Amendment and identified claims 1-20 and 25 as allowable. No comments on allowance were provided by the Examiner. The '183 patent issued on September 25, 2012.

**V. THERE IS A REASONABLE LIKELIHOOD THAT AT LEAST ONE CLAIM OF THE '183 PATENT IS UNPATENTABLE UNDER 37 C.F.R. § 42.104(b)(4)**

**A. Identification of the References as Prior Art**

U.S. Patent No. 3,321,787 to Myers was filed December 17, 1964, and issued May 30, 1967. Therefore, Myers is prior art to the '183 patent under 35 U.S.C. § 102(b).

U.S. Patent No. 3,936,899 to Henkin was filed March 7, 1974, and issued February 10, 1976. Henkin is a divisional of U.S. Patent Application No. 275,173, filed July 26, 1972. Therefore, Henkin is prior art to the '183 patent under 35 U.S.C. § 102(b).

U.S. Patent No. 4,100,641 to Pansini was filed June 24, 1976, and issued July 18, 1978. Therefore, Pansini is prior art to the '183 patent under 35 U.S.C. § 102(b).

U.S. Patent No. 4,429,429 to Altschul was filed August 12, 1981, and issued February 7, 1984. Therefore, Altschul is prior art to the '183 patent under 35 U.S.C. § 102(b).

None of Myers, Henkin, Pansini, or Altschul was of record during prosecution of the '183 patent, and none was relied upon in any rejection of the claims.

### **B. Summary of Invalidity Arguments**

Claims 1-14, 16, and 19-21 of the '183 patent include elements that have been known for decades. For example, in 1967, Robert R. Myers filed a patent application disclosing a self propelled cleaner having a housing, a water inlet, rotationally-mounted supports, a water pump mounted in the interior of the housing, and a stationary directional discharge conduit. Myers also discloses discharging a pressurized stream of water at an acute angle to propel the cleaner along the pool surface. (*See Ex. 1001*).

Myers, and the prior art cited herein by Petitioner, were not before the Patent Office during examination of the '183 patent. Each of the prior art references cited herein, however, are relevant to the issued claims of the '183 patent. For example, each of the prior art references cited herein disclose a self propelled pool cleaner that uses a water jet to propel the cleaner along a pool surface. Notably, each of the prior art references cited herein also disclose discharging the water jet at an acute angle, with respect to the surface on which the cleaner moves. For example, Myers (*Ex. 1001, Fig. 2*) discloses that the discharge (33) is disposed at an acute angle; Henkin (*Ex. 1002, Fig. 4*) discloses that the discharge (90) is disposed at an acute angle; Pansini (*Ex. 1003, Fig. 3*) discloses that the discharge (20, 22) is disposed at an acute angle; and Altschul (*Ex. 1004, Fig. 4*) discloses that the discharge (36) is disposed at an acute angle.

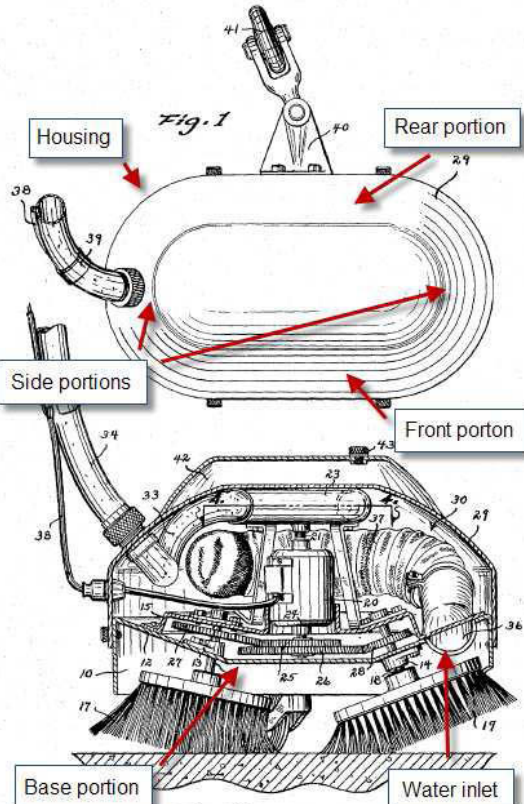
Further, the prior art cited herein identifies and solves one of the problems allegedly solved by the alleged invention of the '183 patent, to ensure full coverage of a pool surface. (*Ex. 1006, Col. 3, ll. 14-20*). For example, Pansini discloses that water discharged from nozzles (20, 22) causes the cleaner to move in opposite directions, not along the same path, but rather, along a deviated path so that over a period of a few hours, the entire pool surface is traversed and cleaned. (*Ex. 1003, Col. 1, ll. 5-8; Col. 3, ll. 10-11, 38-43; Col. 5, ll. 33-41*).

Accordingly, each of the claim limitations of claims 1-14, 16, and 19-21 of the '183 patent are disclosed or taught by prior art cited herein, as demonstrated in Section VI below.

## **VI. DETAILED EXPLANATION UNDER 37 C.F.R. §§ 42.104(b)**

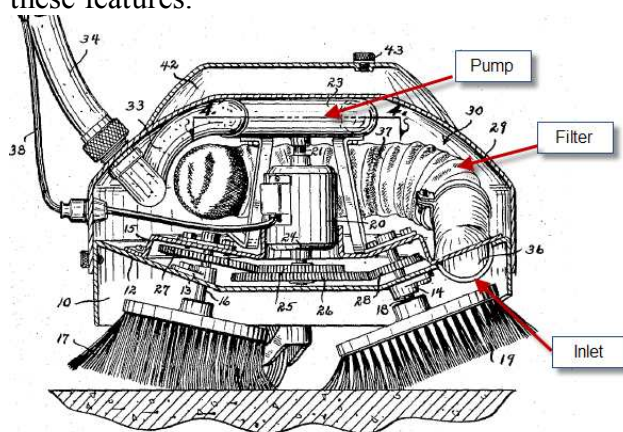
### **A. Claim 1 (Independent)**



<b>Claim 1</b>	<b>Anticipated By Myers (Ex. 1001)</b>
<p>A self-propelled cleaning apparatus for cleaning a submerged surface of a pool or tank, comprising:</p>	<p>Myers discloses a self-propelled cleaning apparatus for cleaning a submerged surface of a pool or tank. For example, Myers describes that “[t]his invention relates to a swimming pool cleaning device and more particularly to a cleaning means that is erratically self-propelled over the bottom surface of the swimming pool.” (Col. 1, ll. 8-11).</p>
<p>a housing having a front portion as defined by the direction of movement of the apparatus when propelled by a water jet, an opposing rear portion and adjoining side portions defining the periphery of the apparatus, and a baseplate with at least one water inlet;</p>	<p>Myers discloses a housing (29) having a front portion, an opposing rear portion and adjoining side portions defining the periphery of the apparatus, and a baseplate with a water inlet (36), as depicted in reference Figures 1&amp; 2 below:</p> 
<p>rotationally-mounted supports coupled proximate the front and rear portions of the housing to enable movement of said apparatus over the submerged surface;</p>	<p>Myers discloses rotationally-mounted supports (19) coupled proximate the front and rear portions of the housing (29), as depicted in reference Figures 2 and 3 below:</p>

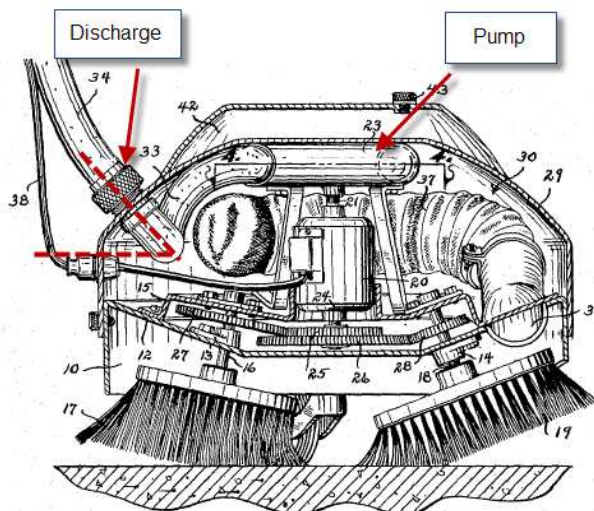
	<p>Fig. 2</p> <p>Rotationally-mounted supports (19)</p> <p>Fig. 3</p> <p>Front portion of housing</p> <p>Rear portion of housing</p> <p>Myers discloses that the rotationally-mounted supports (19) enable movement of the cleaner over the submerged surface, “[o]bviously the movement of the unit is caused by the rotating scrubbing elements [19].” (Col. 2, ll. 55-59).</p>
<p>a water pump mounted in the interior of said housing, said water pump being configured to draw water and debris from the pool or tank through the at least one water inlet for filtering; and</p>	<p>Myers discloses a water pump (23) mounted in the interior of said housing (29), said water pump being configured to draw water and debris from the pool or tank through the water inlet (36) for filtering. For example, Myers describes that “[i]n [] compartment [30] is the pump-motor 23 having the usual inlet opening 31 and outlet opening 32. The inlet opening 31 communicates with the inside of the compartment 30.” (Col. 2, ll. 8-11). Water is drawn through the “passageway [36] in the bottom of the compartment 30 . . . Detachably secured to this passageway 36 is a pocket-type noncollapsible</p>

filter 37. This filter is inside the compartment and its porous wall permits water to pass through but not collectible foreign matter.” (Col. 2, ll. 22-28). Reference Figure 2 further illustrates these features:

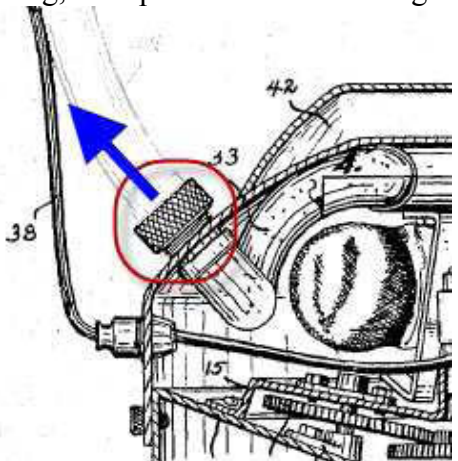


a stationary directional discharge conduit in fluid communication with the water pump and having at least one discharge opening through which a pressurized stream of water forming the water jet is directionally discharged at a predetermined angle that is acute with respect to the surface over which the apparatus is moving.

Myers discloses a stationary directional discharge conduit (33) in fluid communication with the water pump (23) and having at least one discharge opening, as depicted in reference Figure 2, below:



Myers discloses that through the discharge conduit (33), a pressurized stream of water forming the water jet is directionally discharged. For example, Myers describes that when the cleaner is configured to use the motor (20) as a pump, then conduit (34) is disconnected from the cleaner and “the water exiting from the unit and into the pool will *provide a jet force to move*

	<p><i>the unit.</i>” (Col. 3, ll. 6-9) (emphasis added). The pressurized stream of water is discharged at a predetermined angle that is acute with respect to the surface over which the apparatus is moving, as depicted in reference Figure 2 below:</p> 
<p><b>Claim 1</b></p>	<p><b>Obvious Over Henkin (Ex. 1002) in View of Myers (Ex. 1001)</b></p>
<p>A self-propelled cleaning apparatus for cleaning a submerged surface of a pool or tank, comprising:</p>	<p>Henkin discloses a self-propelled cleaning apparatus for cleaning a submerged surface of a pool or tank. For example, Henkin describes that “[t]he car wheels are driven by a water powered turbine to propel the car in a forward direction, along the vessel surface.” (Abstract).</p>
<p>a housing having a front portion as defined by the direction of movement of the apparatus when propelled by a water jet, an opposing rear portion and adjoining side portions defining the periphery of the apparatus, and a baseplate with at least one water inlet;</p>	<p>Henkin discloses a housing (32) having a front portion, an opposing rear portion and adjoining side portions (40) defining the periphery of the apparatus, and a baseplate (38) with a water inlet (112), as depicted in reference Figures 4 and 5 below:</p>

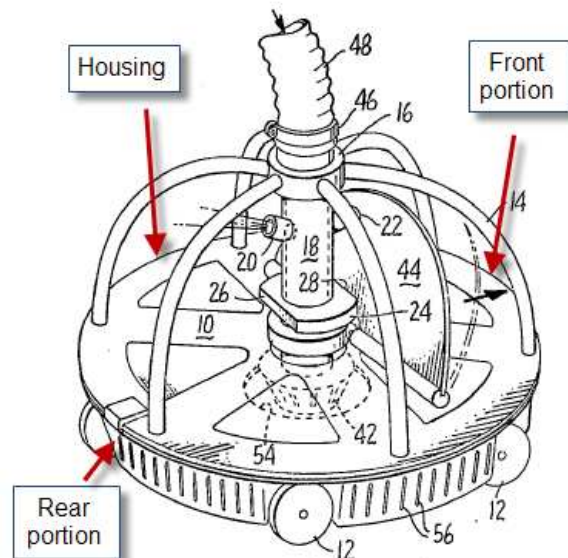
<p>rotationally-mounted supports coupled proximate the front and rear portions of the housing to enable movement of said apparatus over the submerged surface;</p>	<p>Henkin discloses rotationally-mounted supports (36A, 36C) coupled proximate the front and rear portions of the housing (32), for example, “the car is propelled along the vessel surface by rotation of the drive wheels 36a and 36b.” (Col. 5, ll.28-29). It would have been obvious to one of ordinary skill in the art to combine the rotationally-mounted supports of Henkin with the brushes of Myers since Myers also uses a wheel (41) for support. Figure 4 below further depicts the rotationally mounted supports of Henkin:</p>

<p>a water pump mounted in the interior of said housing, said water pump being configured to draw water and debris from the pool or tank through the at least one water inlet for filtering; and</p>	<p>Henkin discloses that an external pump (70) provides high pressure flow to the cleaner via a supply hose (69). (Col. 4, ll. 35-41). The pressurized water is discharged from the orifice (118) to produce a suction at the entrance of the water inlet (112), which causes water and debris to be drawn from the pool into the water inlet (112) and through a filter (124). (Col. 6, ll. 20-34). To prevent entanglement of the pool cleaner with the supply hose (69), the hose includes floats and swivel couplings (164, 170). (Col. 6, ll. 37-52).</p> <p>Myers discloses a water pump mounted in the interior housing of a pool cleaner, used to draw water and debris from the pool through a water inlet for filtering. (Col. 2, ll. 8-11).</p> <p>It would have been obvious to one of ordinary skill in the art to combine the internally mounted pump of Myers with Henkin to eliminate the need for an external source of pressurized water, a supply hose, and the need to manage the supply hose in order to prevent entanglement.</p>
<p>a stationary directional discharge conduit in fluid communication with the water pump and having at least one discharge opening through which a pressurized stream of water forming the water jet is directionally discharged at a predetermined angle that is acute with respect to</p>	<p>Henkin discloses a stationary directional discharge conduit (90) in fluid communication with the water pump (70) and having at least one discharge opening, for example, “[t]he nozzle 90 is preferably mounted on some type of universal fitting such as a ball coupling 92 which couples</p>

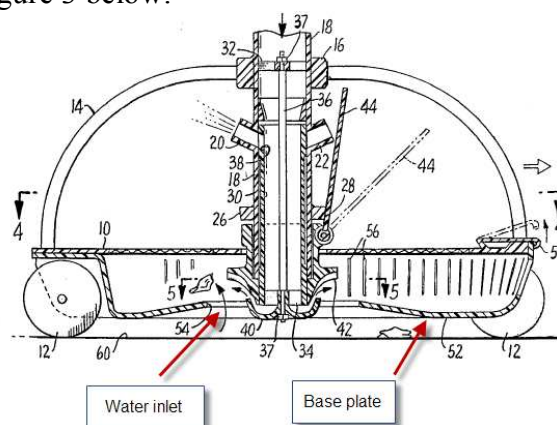
<p>the surface over which the apparatus is moving.</p>	<p>the nozzle to the supply manifold 66 for receiving a high pressure water supply from booster pump 70.” (Col. 5, ll. 15-18).</p> <p>Henkin discloses that through the discharge conduit (90), a pressurized stream of water forming the water jet is directionally discharged, for example, “thrust is produced by a water jet discharged from a directionally adjustable nozzle 90.” (Col. 5, ll. 6-10).</p> <p>Henkin discloses that the water jet is discharged at a predetermined angle that is acute with respect to the surface over which the apparatus is moving, for example, “[t]he angle of the nozzle 90 is selected to yield both a downward thrust component (i.e. normal to the vessel surface) for providing traction and a forward component which aids in propelling the car and facilitates the car climbing vertical surfaces and working itself out of corners.” (Col. 5, ll. 19-24). Reference Figure 4 below, further illustrates these features:</p>
<p><b>Claim 1</b></p>	<p><b>Obvious Over Pansini (Ex. 1003) in View of Myers (Ex. 1001)</b></p>
<p>A self-propelled cleaning apparatus for cleaning a submerged surface of a pool or tank, comprising:</p>	<p>Pansini discloses a self-propelled cleaning apparatus for cleaning a submerged surface of a pool or tank. For example, Pansini describes “[a] jet-powered submerged cleaner runs along the bottom of a pool and also up and down the side walls.” (Abstract).</p>
<p>a housing having a front portion as defined by</p>	<p>Pansini discloses a housing (10) having a front</p>

the direction of movement of the apparatus when propelled by a water jet, an opposing rear portion and adjoining side portions defining the periphery of the apparatus, and a baseplate with at least one water inlet;

portion as defined by the direction of movement of the apparatus when propelled by a water jet, an opposing rear portion and adjoining side portions defining the periphery of the apparatus, as depicted in reference Figure 1 below:



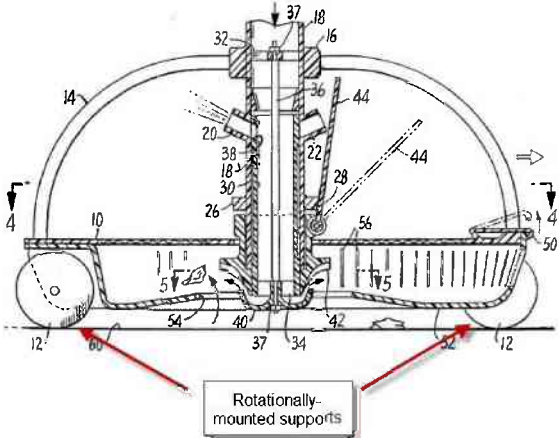
Pansini discloses a baseplate (52) with at least one water inlet (54), as depicted in reference Figure 3 below:

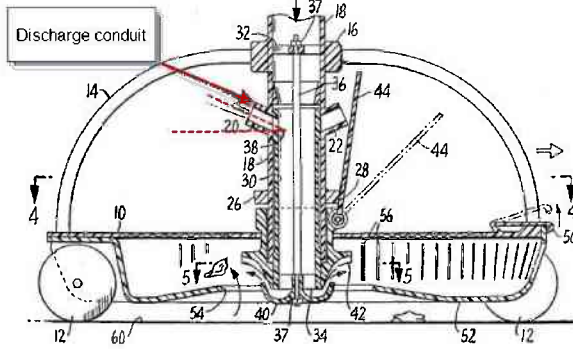


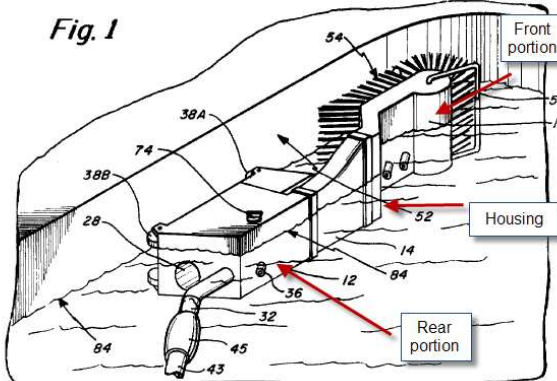
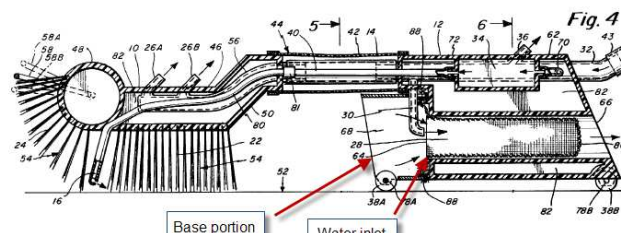
rotationally-mounted supports coupled proximate the front and rear portions of the housing to enable movement of said apparatus over the submerged surface;

Pansini discloses rotationally-mounted supports (12) coupled proximate the front and rear portions of the housing to enable movement of said apparatus over the submerged surface, for example, “the cleaner comprises a plate or platform member 10 supported by wheels 12.” (Col. 2, ll. 41-44). It would have been obvious



	<p>to one of ordinary skill in the art to combine the rotationally-mounted supports of Pansini with the brushes of Myers since Myers also uses a wheel (41) for support. Reference Figure 3 below further depicts the rotationally-mounted supports of Pansini:</p> 
<p>a water pump mounted in the interior of said housing, said water pump being configured to draw water and debris from the pool or tank through the at least one water inlet for filtering; and</p>	<p>Pansini discloses that a flexible hose (48) is attached to the cleaner at one end (18), extends to the surface, and connects to an external pump at the opposite end to deliver pressurized water to the cleaner. (Col. 2: ll. 61-65). The pressurized water produces a suction at the entrance of the water inlet (54), which causes water and debris to be drawn from the pool into the water inlet (54) and through a filtration compartment. (Col. 3, ll. 19-27).</p> <p>Myers discloses a water pump mounted in the interior housing of a pool cleaner, used to draw water and debris from the pool through a water inlet for filtering. (Col. 2, ll. 8-11). Furthermore, Myers uses a wheel in addition to brushes.</p> <p>It would have been obvious to one of ordinary skill in the art to combine the internally mounted pump of Myers with Pansini to eliminate the need for an external source of pressurized water and a supply hose.</p>
<p>a stationary directional discharge conduit in fluid communication with the water pump and having at least one discharge opening through</p>	<p>Pansini discloses a stationary directional discharge conduit (20, 22) in fluid communication with the water pump and having</p>

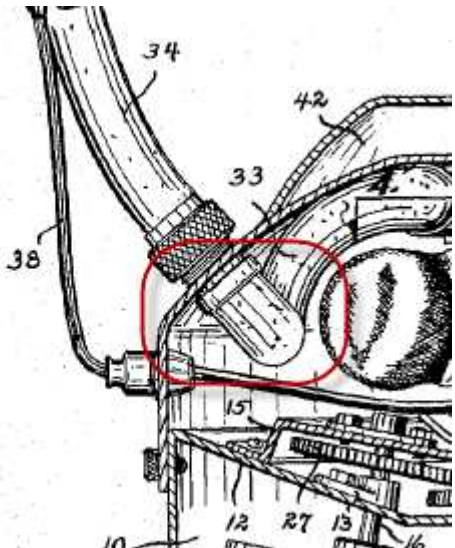
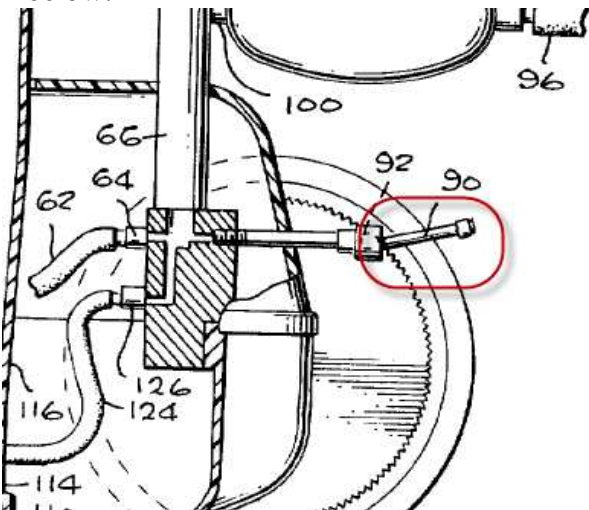
<p>which a pressurized stream of water forming the water jet is directionally discharged at a predetermined angle that is acute with respect to the surface over which the apparatus is moving.</p>	<p>at least one discharge opening, for example, “[p]art of the water coming down the tube 18 passes out the drive nozzle 20.” (Col. 3, ll. 12-13).</p> <p>Pansini discloses that through the discharge conduit (20, 22), a pressurized stream of water forming the water jet is directionally discharged, for example, “[t]he water jet issuing from the active drive jet nozzle . . . .” (Col. 5, ll. 26-27).</p> <p>Pansini discloses that water jet is discharged at a predetermined angle that is acute with respect to the surface over which the apparatus is moving, as depicted in reference Figure 3 below:</p> 
<p><b>Claim 1</b></p>	<p><b><i>Obvious Over Altschul (Ex. 1004) in View of Myers (Ex. 1001)</i></b></p>
<p>A self-propelled cleaning apparatus for cleaning a submerged surface of a pool or tank, comprising:</p>	<p>Altschul discloses a self-propelled cleaning apparatus for cleaning a submerged surface of a pool or tank. For example, Altschul describes “[a] device for cleaning the sidewalls of a swimming pool at the waterline region is self-propelled by water jets which also urge the device against the pool sidewall.” (Abstract).</p>
<p>a housing having a front portion as defined by the direction of movement of the apparatus when propelled by a water jet, an opposing rear portion and adjoining side portions defining the periphery of the apparatus, and a baseplate with at least one water inlet;</p>	<p>Altschul discloses a housing having a front portion (10) as defined by the direction of movement of the apparatus when propelled by a water jet, an opposing rear portion (12) and adjoining side portions defining the periphery of the apparatus, as depicted in reference Figure 1 below:</p>

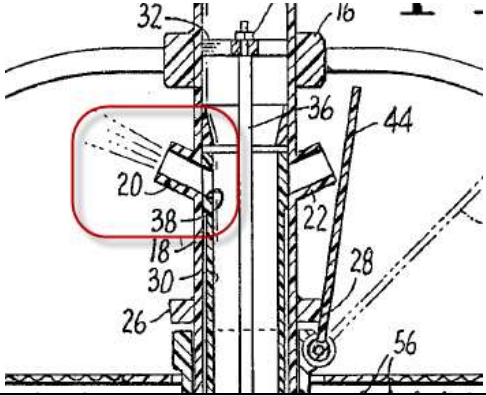
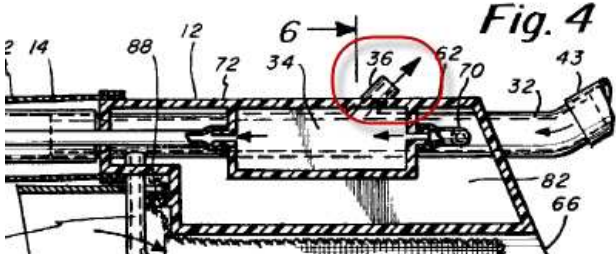
	<p><b>Fig. 1</b></p>  <p>Altschul discloses a baseplate (88) with at least one water inlet (64), as depicted in reference Figure 4 below:</p> <p><b>Fig. 4</b></p> 
<p>rotationally-mounted supports coupled proximate the front and rear portions of the housing to enable movement of said apparatus over the submerged surface;</p>	<p>Altschul discloses rotationally-mounted supports (38A, 38B) coupled proximate the front and rear portions of the housing to enable movement of said apparatus over the submerged surface, for example, “[a] leading wheel set comprised of two wheels 38A mounted on an axle 78A is supported at the front end of the filtration chamber sleeve 68. A trailing wheel set comprised of two wheels 38B mounted on an axle 78B is supported at the rear end of the trailing portion casing 62.” (Col. 4, l. 67-Col. 5, l. 3). It would have been obvious to one of ordinary skill in the art to combine the rotationally-mounted supports of Altschul with the brushes of Myers since Myers also uses a wheel (41) and brushes for support. Reference Figure 4 below further depicts the rotationally-mounted support feature of Altschul:</p>

<p>a water pump mounted in the interior of said housing, said water pump being configured to draw water and debris from the pool or tank through the at least one water inlet for filtering; and</p>	<p>Altschul discloses that a flexible hose (43) is connected to the cleaner at main inlet tube (32) at one end, and a source of pressurized water at the other end. “The hose 43 has one or more floats 45 which keep the hose 43 afloat so as not to drag downwardly on the device.” (Col. 4, ll. 8-22). A portion of the pressurized water flows through “the elongated water propulsion jet 30 [and] is directed rearward through the filtration chamber 28. Thus, not only does the flow from the elongated water propulsion jet 30 assist in propelling the device in a forward direction, it also creates a suction effect as the device travels through the water whereby water tends to be drawn into the filtration chamber 28 through the filtration chamber entrance 64 and out the filtration chamber exit 66.” (Col. 6, ll. 18-27). Debris loosened by the brush portions (22, 24) is drawn into the filtration chamber (28) where the dirt may be filtered from the water by the filtration bag (86). (Col. 6, ll. 27-32).</p> <p>Myers discloses a water pump mounted in the interior housing of a pool cleaner, used to draw water and debris from the pool through a water inlet for filtering. (Col. 2, ll. 8-11). Brushes (19) scrub the pool floor, causing debris to be loosened and drawn into the filter. (Col. 2, ll. 63-66; Col. 3, ll. 35-37). Furthermore, Myers uses a wheel in addition to brushes.</p> <p>Both Altschul and Myers disclose a self-propelled pool cleaner that uses pressurized water to propel the cleaner, draw water through an inlet for filtering, and a brush element to scrub a pool surface to remove debris.</p>

	<p>Therefore, it would have been obvious to one of ordinary skill in the art to combine the internally mounted pump of Myers with Altschul to eliminate the need for an external source of pressurized water and a supply hose.</p>
<p>a stationary directional discharge conduit in fluid communication with the water pump and having at least one discharge opening through which a pressurized stream of water forming the water jet is directionally discharged at a predetermined angle that is acute with respect to the surface over which the apparatus is moving.</p>	<p>Altschul discloses a stationary directional discharge conduit (26A, 26B, 36) in fluid communication with the water pump and having at least one discharge opening, for example, “[o]nce the device is connected to the water source, some of the water travelling into the main inlet tube 32 is fed to the water propulsion jet 36 . . . and exits through the two water propulsion jets 26A and 26B.” (Col. 5, ll. 46-55).</p> <p>Altschul discloses that through the discharge conduit (26A, 26B, 36), a pressurized stream of water forming the water jet is directionally discharged, for example, “[t]he force of the water rushing out of the water propulsion jets propels the pool cleaner in a forward direction while urging the device against the sidewall 52 of the swimming pool.” (Col. 5, ll. 55-58).</p> <p>Altschul discloses that water jet is discharged at a predetermined angle that is acute with respect to the surface over which the apparatus is moving, for example, “[w]ater jets 26A, 26B, and 36 are aimed toward the rear of the device and away from the sidewall of the swimming pool . . . .” (Col. 5, ll. 58-60). Reference Figure 4 below, illustrates this feature:</p>

**B. Claim 2 (Dependent)**

<i>Claim 2</i>	<i>Anticipated By Myers (Ex. 1001)</i>
The apparatus of claim 1,	Myers discloses each of the limitations recited in independent claim 1.
in which the discharge conduit is linear in shape.	<p>Myers discloses that the discharge conduit (33) is linear in shape, as depicted in reference Figure 2 below:</p> 
<i>Claim 2</i>	<i>Obvious Over Henkin (Ex. 1002) in View of Myers (Ex. 1001)</i>
The apparatus of claim 1,	The combination of Henkin and Myers teaches each of the limitations in independent claim 1.
in which the discharge conduit is linear in shape.	<p>Henkin discloses that the discharge conduit (90) is linear in shape, as depicted in reference Figure 4 below:</p> 

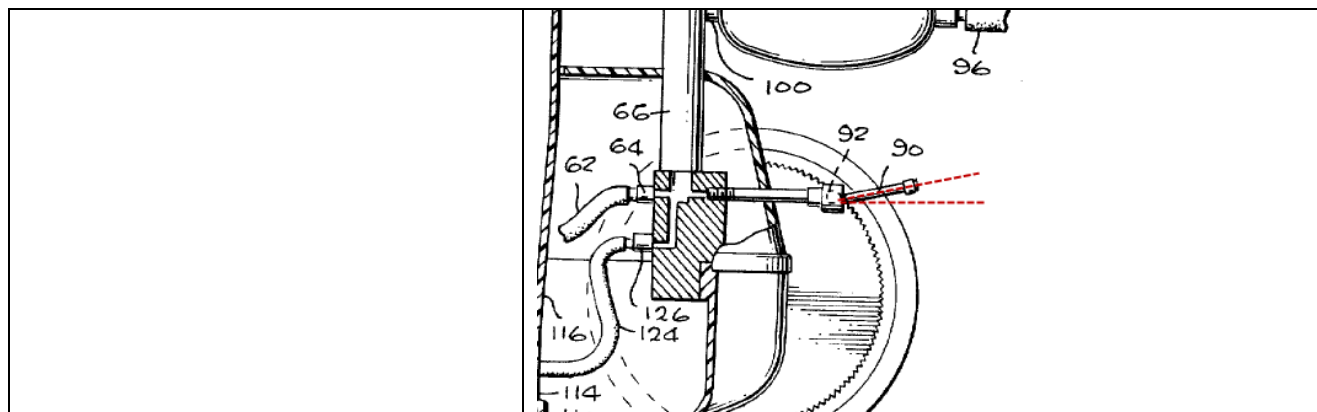
<b>Claim 2</b>	<b>Obvious Over Pansini (Ex. 1003) in View of Myers (Ex. 1001)</b>
The apparatus of claim 1,	The combination of Pansini and Myers teaches each of the limitations in independent claim 1.
in which the discharge conduit is linear in shape.	Pansini discloses that the discharge conduit (20) is linear in shape, as depicted in reference Figure 3 below: 
<b>Claim 2</b>	<b>Obvious Over Altschul (Ex. 1004) in View of Myers (Ex. 1001)</b>
The apparatus of claim 1,	The combination of Altschul and Myers teaches each of the limitations in independent claim 1.
in which the discharge conduit is linear in shape.	Altschul discloses that the discharge conduit (36) is linear in shape, as depicted in reference Figure 4 below: 

**C. Claim 3 (Dependent)**

<b>Claim 3</b>	<b>Anticipated By Myers (Ex. 1001)</b>
The apparatus of claim 1,	Myers discloses each of the limitations recited in independent claim 1.
wherein a portion of the discharge conduit terminating in the at least one discharge opening is fixed at a predetermined upward angle with respect to the surface over which the apparatus is moving,	Myers discloses that a portion of the discharge conduit (33) is fixed at a predetermined upward angle with respect to the surface over which the apparatus is moving, as depicted in reference Figure 2 below:

<p>wherein the water jet discharged produces a resultant force vector that crosses a plane passing through between the axes of rotation of the front and rear rotationally-mounted supports.</p>	<p>Myers discloses that the water jet discharged produces a resultant force vector, for example, “the water exiting from the unit and into the pool will <i>provide a jet force to move the unit.</i>” (Col. 3, ll. 6-9) (emphasis added).</p> <p>The resultant force vector crosses a plane passing through between the axes of rotation of the front and rear rotationally-mounted supports, as depicted in reference Figure 2 below:</p>
<p><b>Claim 3</b></p>	<p><b>Obvious Over Henkin (Ex. 1002) in View of Myers (Ex. 1001)</b></p>
<p>The apparatus of claim 1,</p>	<p>The combination of Henkin and Myers teaches each of the limitations in independent claim 1.</p>
<p>wherein a portion of the discharge conduit terminating in the at least one discharge opening is fixed at a predetermined upward angle with respect to the surface over which the apparatus is moving,</p>	<p>Henkin discloses that a portion of the discharge conduit (90) is fixed at a predetermined upward angle with respect to the surface over which the apparatus is moving, as depicted in reference Figure 4 below:</p>

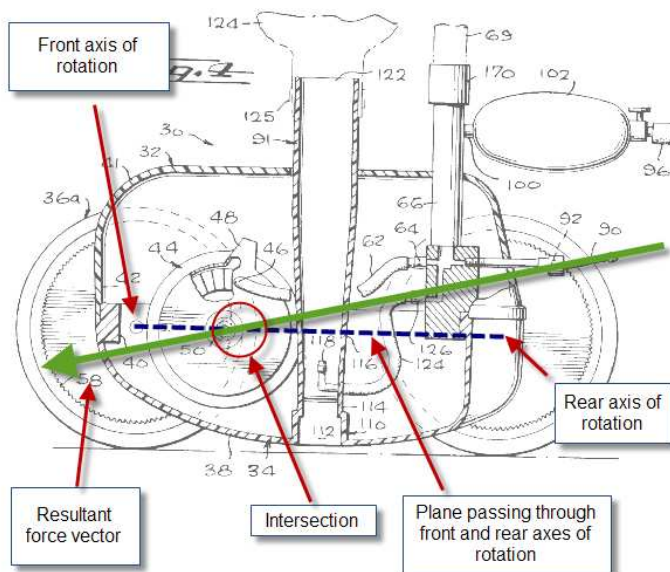




wherein the water jet discharged produces a resultant force vector that crosses a plane passing through between the axes of rotation of the front and rear rotationally-mounted supports.

Henkin discloses that the water jet discharged produces a resultant force vector, for example, “thrust is produced by a water jet discharged from a directionally adjustable nozzle 90.” (Col. 5, ll. 6-10).

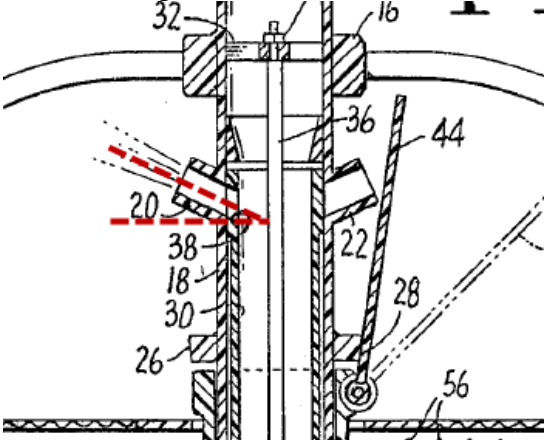
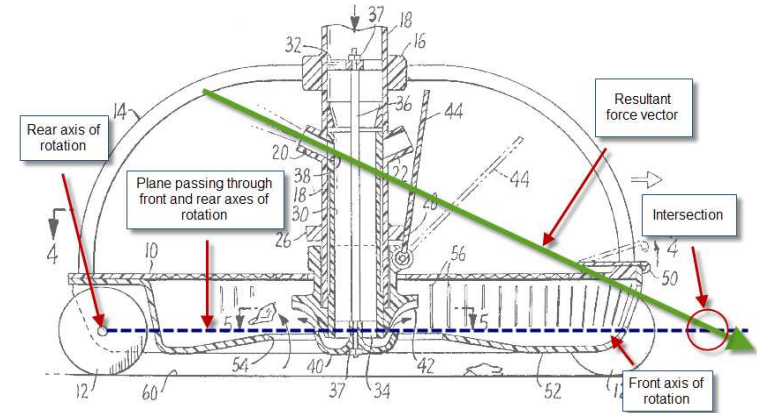
The resultant force vector crosses a plane passing through between the axes of rotation of the front and rear rotationally-mounted supports (36A), as depicted in reference Figure 4 below:

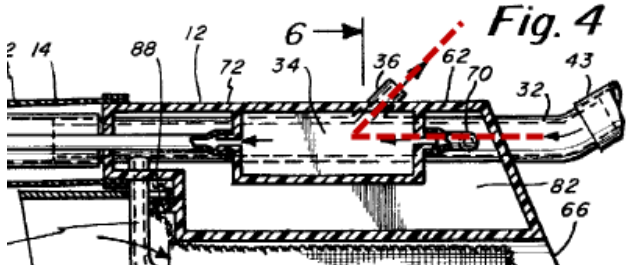
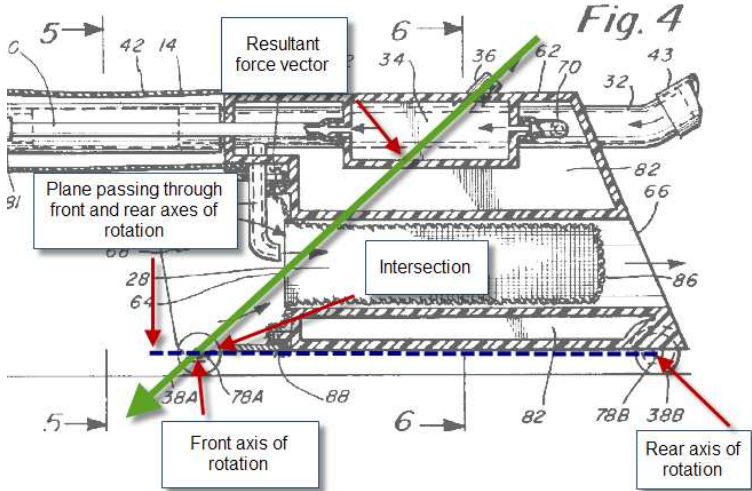


<b>Claim 3</b>	<b><i>Obvious Over Pansini (Ex. 1003) in View of Myers (Ex. 1001)</i></b>
----------------	---

The apparatus of claim 1,	The combination of Pansini and Myers teaches each of the limitations in independent claim 1.
---------------------------	--

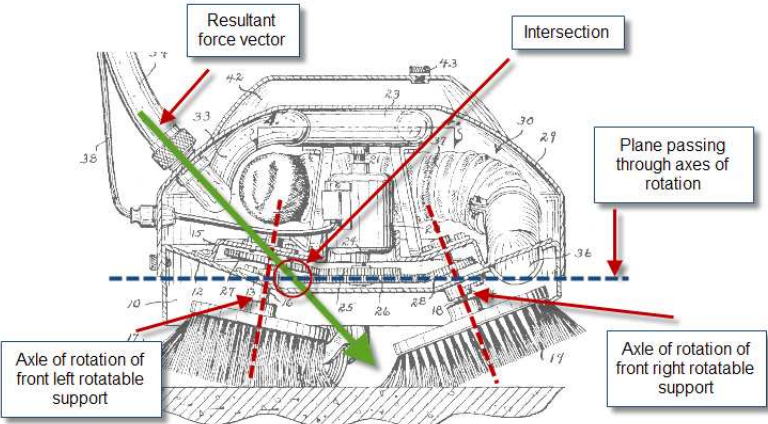
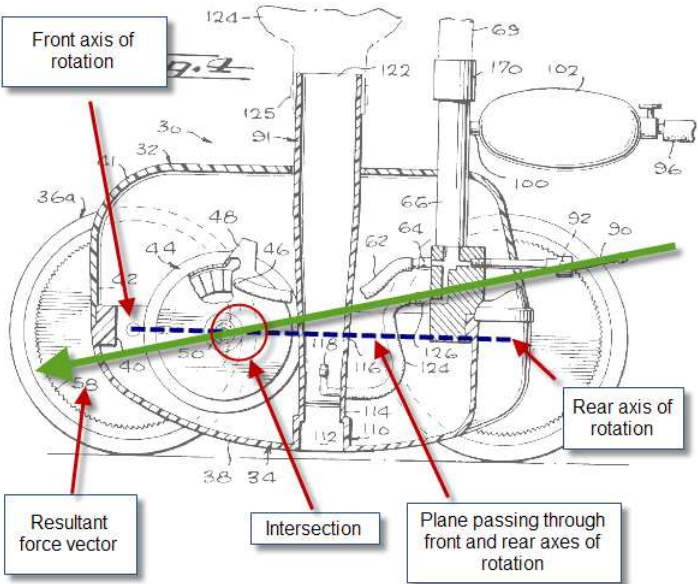
wherein a portion of the discharge	Pansini discloses that a portion of the discharge conduit (20)
------------------------------------	--

<p>conduit terminating in the at least one discharge opening is fixed at a predetermined upward angle with respect to the surface over which the apparatus is moving,</p>	<p>is fixed at a predetermined upward angle with respect to the surface over which the apparatus is moving, as depicted in reference Figure 3 below:</p> 
<p>wherein the water jet discharged produces a resultant force vector that crosses a plane passing through between the axes of rotation of the front and rear rotationally-mounted supports.</p>	<p>Pansini discloses that the water jet discharged produces a resultant force vector, for example, “[t]he described hold-down force is augmented by the angular disposition of the jet nozzles 20 and 22, i.e. each of the drive jets furnishes an additional component of hold-down force to the cleaner.” (Col. 3, l. 66-Col. 4, l. 2).</p> <p>The resultant force vector crosses a plane passing through between the axes of rotation of the front and rear rotationally-mounted supports (12), as depicted in reference Figure 3 below:</p> 
<p><b>Claim 3</b></p>	<p><b>Obvious Over Altschul (Ex. 1004) in View of Myers (Ex. 1001)</b></p>
<p>The apparatus of claim 1,</p>	<p>The combination of Altschul and Myers teaches each of the limitations in independent claim 1.</p>
<p>wherein a portion of the discharge conduit terminating in the at least one</p>	<p>Altschul discloses that a portion of the discharge conduit (36) is fixed at a predetermined upward angle with respect</p>

<p>discharge opening is fixed at a predetermined upward angle with respect to the surface over which the apparatus is moving,</p>	<p>to the surface over which the apparatus is moving, as depicted in reference Figure 4 below:</p> 
<p>wherein the water jet discharged produces a resultant force vector that crosses a plane passing through between the axes of rotation of the front and rear rotationally-mounted supports.</p>	<p>Altschul discloses that the water jet discharged produces a resultant force vector, for example, “[t]he force of the water rushing out of the water propulsion jets propels the pool cleaner in a forward direction while urging the device against the sidewall 52 of the swimming pool.” (Col. 5, ll. 55-58).</p> <p>The resultant force vector crosses a plane passing through between the axes of rotation of the front and rear rotationally-mounted supports (38A), as depicted in reference Figure 4 below:</p> 

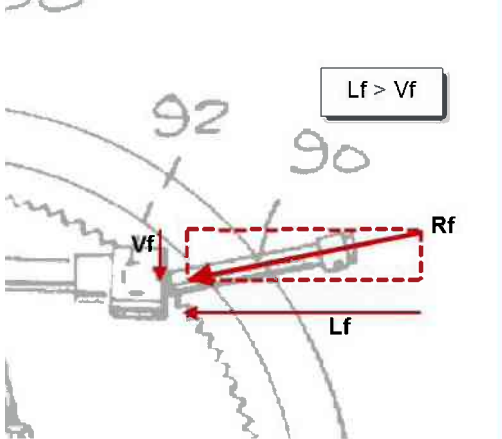
**D. Claim 4 (Dependent)**

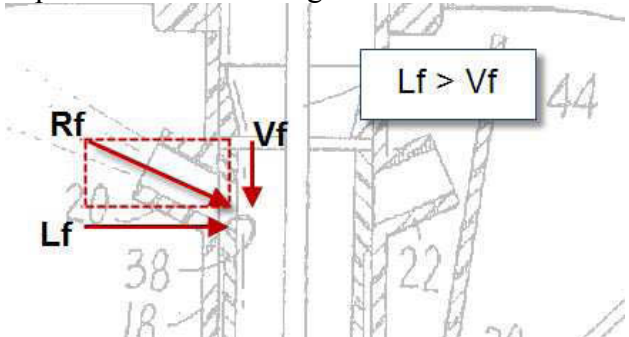
<i>Claim 4</i>	<i>Anticipated By Myers (Ex. 1001)</i>
The apparatus of claim 3	Myers discloses each of the limitations recited in claims 1 and 3.
in which the resultant force vector crosses the plane proximate the axis of rotation of the supports	Myers discloses that the resultant force vector crosses the plane proximate the axis of rotation of the supports mounted proximately the front of the apparatus, as depicted in reference

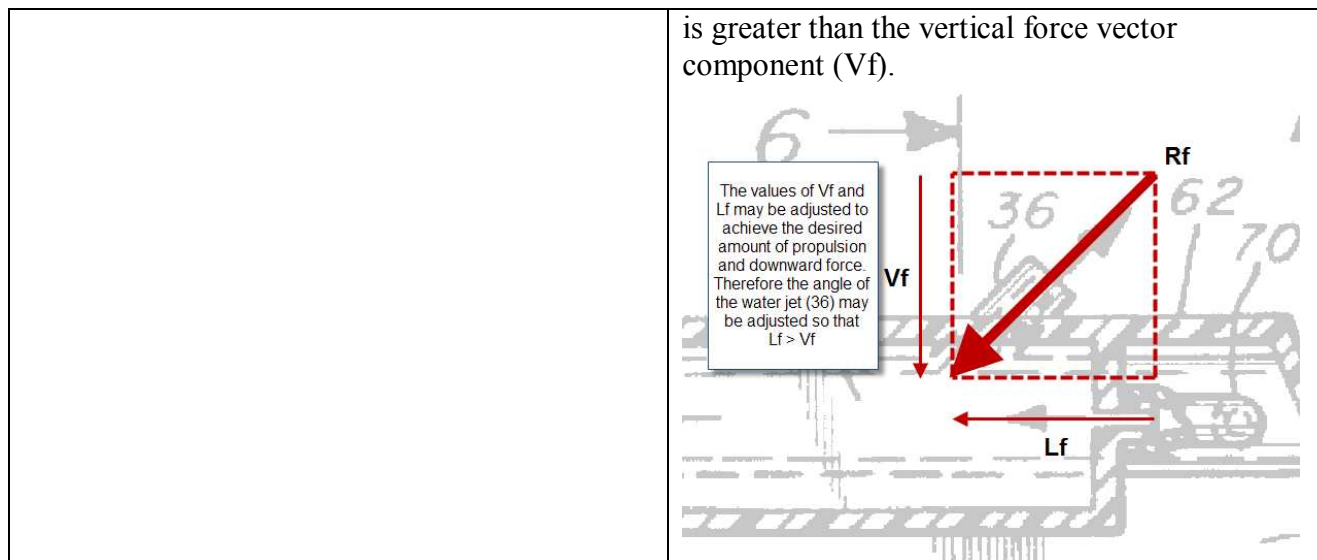
<p>mounted proximately the front of the apparatus.</p>	<p>Figure 2 below:</p> 
<p><b>Claim 4</b></p>	<p><b>Obvious Over Henkin (Ex. 1002) in View of Myers (Ex. 1001)</b></p>
<p>The apparatus of claim 3</p>	<p>The combination of Henkin and Myers teaches each of the limitations in claims 1 and 3.</p>
<p>in which the resultant force vector crosses the plane proximate the axis of rotation of the supports mounted proximately the front of the apparatus.</p>	<p>Henkin discloses that the resultant force vector crosses the plane proximate the axis of rotation of the supports mounted proximately the front of the apparatus, as depicted in reference Figure 4 below:</p> 
<p><b>Claim 4</b></p>	<p><b>Obvious Over Pansini (Ex. 1003) in View of Myers (Ex. 1001)</b></p>
<p>The apparatus of claim 3</p>	<p>The combination of Pansini and Myers teaches each of the</p>

<p>in which the resultant force vector crosses the plane proximate the axis of rotation of the supports mounted proximately the front of the apparatus.</p>	<p>limitations in claims 1 and 3.</p> <p>Pansini discloses that the resultant force vector crosses the plane proximate the axis of rotation of the supports mounted proximately the front of the apparatus, as depicted in reference Figure 3 below:</p>
<p><b>Claim 4</b></p>	<p><b>Obvious Over Altschul (Ex. 1004) in View of Myers (Ex. 1001)</b></p>
<p>The apparatus of claim 3</p>	<p>The combination of Altschul and Myers teaches each of the limitations in claims 1 and 3.</p>
<p>in which the resultant force vector crosses the plane proximate the axis of rotation of the supports mounted proximately the front of the apparatus.</p>	<p>Altschul discloses that the resultant force vector crosses the plane proximate the axis of rotation of the supports mounted proximately the front of the apparatus, as depicted in reference Figure 4 below:</p>

**E. Claim 5 (Dependent)**

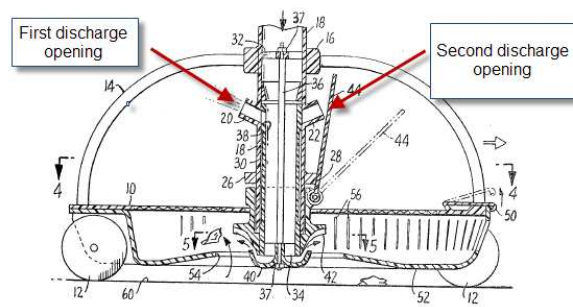
<i>Claim 5</i>	<i>Obvious Over Henkin (Ex. 1002) in View of Myers (Ex. 1001)</i>
<p>The apparatus of claim 3,</p> <p>wherein the resultant force vector discharged from said discharge opening includes a longitudinal force vector component and a vertical force vector component, said longitudinal force vector component being aligned with the longitudinal axis of the apparatus and being greater than the vertical force vector component.</p>	<p>The combination of Henkin and Myers teaches each of the limitations in claims 1 and 3.</p> <p>Henkin discloses that the resultant force vector (Rf) discharged from said discharge opening (90) includes a longitudinal force vector component (Lf) and a vertical force vector component (Vf), for example, “[t]he angle of the nozzle 90 is selected to yield both a downward thrust component (i.e. normal to the vessel surface) for providing traction and a forward component which aids in propelling the car and facilitates the car climbing vertical surfaces and working itself out of corners.” (Col. 5, ll. 19-24).</p> <p>Henkin discloses that that the longitudinal force vector component (Lf) is aligned with the longitudinal axis of the apparatus and is greater than the vertical force vector component (Vf), as depicted in reference Figure 4 below:</p> 
<i>Claim 5</i>	<i>Obvious Over Pansini (Ex. 1003) in View of Myers (Ex.1001)</i>
<p>The apparatus of claim 3,</p> <p>wherein the resultant force vector discharged from said discharge opening includes a longitudinal force vector component and a vertical force vector component, said</p>	<p>The combination of Pansini and Myers teaches each of the limitations in claims 1 and 3.</p> <p>Pansini discloses that the resultant force vector (Rf) discharged from said discharge opening (20, 22) includes a longitudinal force vector component (Lf) and a vertical force vector</p>

<p>longitudinal force vector component being aligned with the longitudinal axis of the apparatus and being greater than the vertical force vector component.</p>	<p>component (Vf), for example, “[t]he described hold-down force is augmented by the angular disposition of the jet nozzles 20 and 22, i.e. each of the drive jets furnishes an additional component of hold-down force to the cleaner.” (Col. 3, l. 66-Col. 4, l. 2).</p> <p>Pansini discloses that the longitudinal force vector component (Lf) is aligned with the longitudinal axis of the apparatus and is greater than the vertical force vector component (Vf), as depicted in reference Figure 4 below:</p> 
<p><b>Claim 5</b></p>	<p><b>Obvious Over Altschul (Ex. 1004) in View of Myers (Ex. 1001)</b></p>
<p>The apparatus of claim 3,</p>	<p>The combination of Altschul and Myers teaches each of the limitations in claims 1 and 3.</p>
<p>wherein the resultant force vector discharged from said discharge opening includes a longitudinal force vector component and a vertical force vector component, said longitudinal force vector component being aligned with the longitudinal axis of the apparatus and being greater than the vertical force vector component.</p>	<p>Altschul discloses that the resultant force vector (Rf) discharged from said discharge opening (36) includes a longitudinal force vector component (Lf) and a vertical force vector component (Vf), for example, “[w]ater jets 26A, 26B and 36 preferably are swivel-type jets which may be adjusted to alter the position of travel of the device, there varying the propulsion and scrubbing characteristics of the device.” (Col. 5, ll. 64-68).</p> <p>Altschul discloses that “[t]he jets can be adjusted to vary propulsion speed, scrubbing force of the brushes, and the like.” (Col. 5, l. 68-Col. 6, l. 2). Accordingly, it would have been obvious to one of ordinary skill in the art to adjust the angle of the jet (36) so that the resultant force vector has a longitudinal force vector component (Lf) that</p>



**F. Claim 6 (Dependent)**

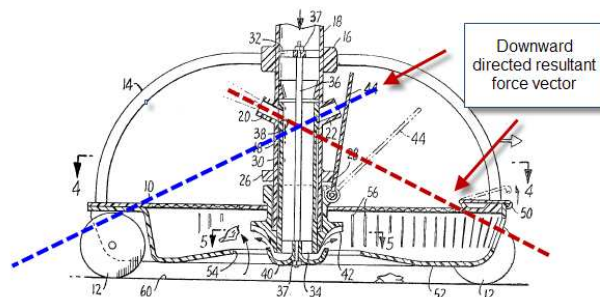
<i>Claim 6</i>	<i>Obvious Over Pansini (Ex. 1003) in View of Myers (Ex. 1001)</i>
The apparatus of claim 1,	The combination of Pansini and Myers teaches each of the limitations in independent claim 1.
wherein the discharge conduit has at least two discharge openings, each of which discharge openings is located at opposite ends of the discharge conduit and	Pansini discloses that the discharge conduit (18) has at least two discharge openings (20, 22), each of which discharge openings is located at opposite ends of the discharge conduit, for example, when the left hand jet nozzle (20) is in operation the cleaner is driven to the right and when the right jet nozzle (22) is in operation the cleaner is driven to the left. (Col. 3, ll. 9-11, 38-40).
each of which discharge openings is configured to produce a downwardly directed resultant force vector in the respective discharged water jet, the resultant vector having a longitudinal	Pansini discloses that each of the openings is configured to produce a downwardly directed resultant force vector in the respective discharged water jet, for example, “[t]he



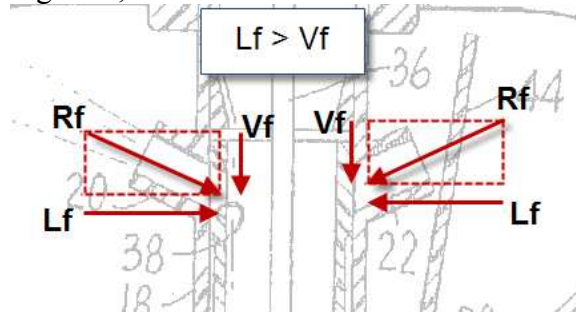


force vector component that is larger than the vertical force vector component.

described hold-down force is augmented by the angular disposition of the jet nozzles 20 and 22, i.e. each of the drive jets furnishes an additional component of hold-down force to the cleaner.” (Col. 3, l. 66-Col. 4, l. 2).



Pansini discloses that each of the resultant vectors has a longitudinal force vector component that is larger than the vertical force vector component, as depicted in reference Figure 4, below:

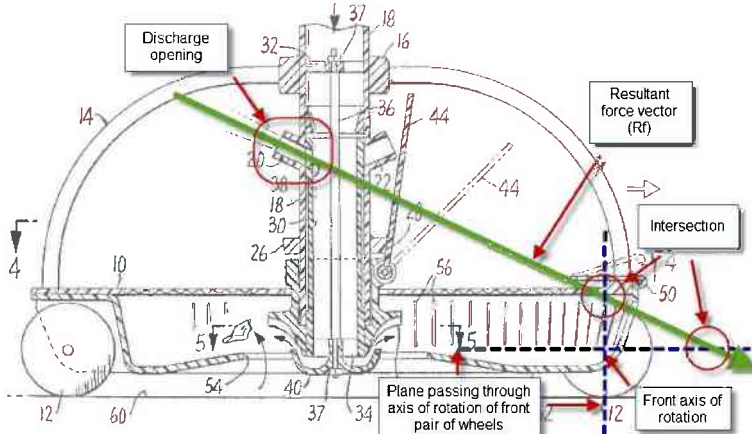


**G. Claim 7 (Dependent)**

<i>Claim 7</i>	<i>Obvious Over Pansini (Ex. 1003) in View of Myers (Ex. 1001)</i>
The apparatus of claim 1,	The combination of Pansini and Myers teaches each of the limitations in independent claim 1.
wherein the rotationally-mounted supports comprise first and second pairs of axially mounted wheels respectively positioned proximate the front and rear portions of the housing.	Pansini discloses that the rotationally-mounted supports (12) comprise first and second pairs of axially mounted wheels respectively positioned proximate the front and rear portions of the housing, for example, “the cleaner comprises a plate or platform member 10 supported by wheels 12.” (Col. 2, ll. 41-44). Reference Figure 4 below depicts this feature:

<p><b>Claim 7</b></p>	<p><b>Obvious Over Altschul (Ex. 1004) in View of Myers (Ex. 1001)</b></p>
<p>The apparatus of claim 1,</p>	<p>The combination of Altschul and Myers teaches each of the limitations in independent claim 1.</p>
<p>wherein the rotationally-mounted supports comprise first and second pairs of axially mounted wheels respectively positioned proximate the front and rear portions of the housing.</p>	<p>Altschul discloses that the rotationally-mounted supports (38A, 38B) comprise first and second pairs of axially mounted wheels respectively positioned proximate the front and rear portions of the housing, for example, “[a] leading wheel set comprised of two wheels 38A mounted on an axle 78A is supported at the front end of the filtration chamber sleeve 68. A trailing wheel set comprised of two wheels 38B mounted on an axle 78B is supported at the rear end of the trailing portion casing 62.” (Col. 4, l. 67-Col. 5, l. 3). Reference Figure 4 below, depicts this feature:</p>

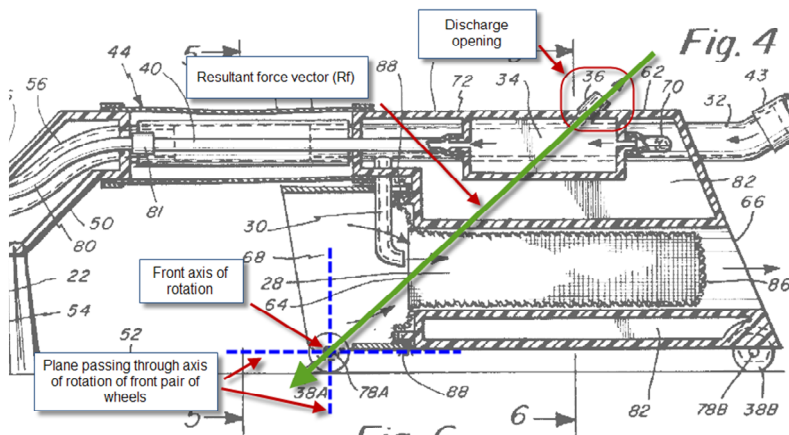
**H. Claim 8 (Dependent)**

<b>Claim 8</b>	<b>Obvious Over Pansini (Ex. 1003) in View of Myers (Ex. 1001)</b>
<p>The apparatus of claim 7,</p> <p>wherein a portion of the discharge conduit terminating in the at least one discharge opening is angled upward with respect to an adjacent portion of the discharge conduit to produce a resultant force vector in the water jet discharged from said at least one discharge opening that is directed to pass through the plane of the axis of rotation of the pair of wheels at the front portion of the apparatus.</p>	<p>The combination of Pansini and Myers teaches each of the limitations in claims 1 and 7.</p> <p>Pansini discloses that a portion of the discharge conduit (18) terminating in a discharge opening (20) is angled upward with respect to an adjacent portion of the discharge conduit (18) to produce a resultant force vector in the water jet discharged from the discharge opening (20), for example, “[t]he described hold-down force is augmented by the angular disposition of the jet nozzles 20 and 22, i.e. each of the drive jets furnishes an additional component of hold-down force to the cleaner.” (Col. 3, l. 66-Col. 4, l. 2).</p> <p>The resultant force vector is directed to pass through the plane of the axis of rotation of the pair of wheels (12) at the front portion of the apparatus, as depicted below in reference Figure 3:</p> 
<b>Claim 8</b>	<b>Obvious Over Altschul (Ex. 1004) in View of Myers (Ex. 1001)</b>
<p>The apparatus of claim 7,</p> <p>wherein a portion of the discharge conduit terminating in the at least one discharge opening is angled upward with respect to an adjacent portion of the discharge conduit to produce a resultant force vector in the water jet discharged from said</p>	<p>The combination of Altschul and Myers teaches each of the limitations in claims 1 and 7.</p> <p>Altschul discloses that a portion of the discharge conduit (32) terminating in a discharge opening (36) is angled upward with respect to an adjacent portion of the discharge conduit (32) to produce a resultant force vector in the water jet discharged from the discharge opening (36), for example, “[t]he force of the water rushing out of the water propulsion jets [36] propels the pool cleaner in a forward direction while urging the</p>

at least one discharge opening that is directed to pass through the plane of the axis of rotation of the pair of wheels at the front portion of the apparatus.

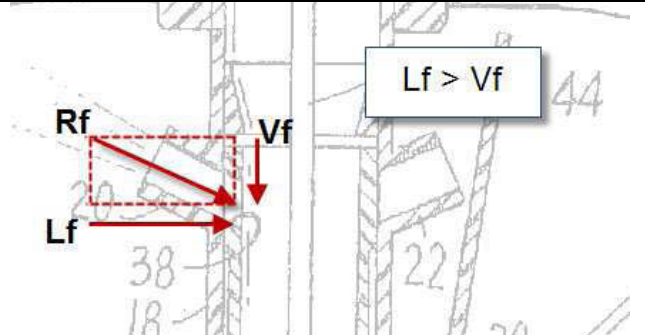
device against the sidewall 52 of the swimming pool.” (Col. 5, ll. 55-58).

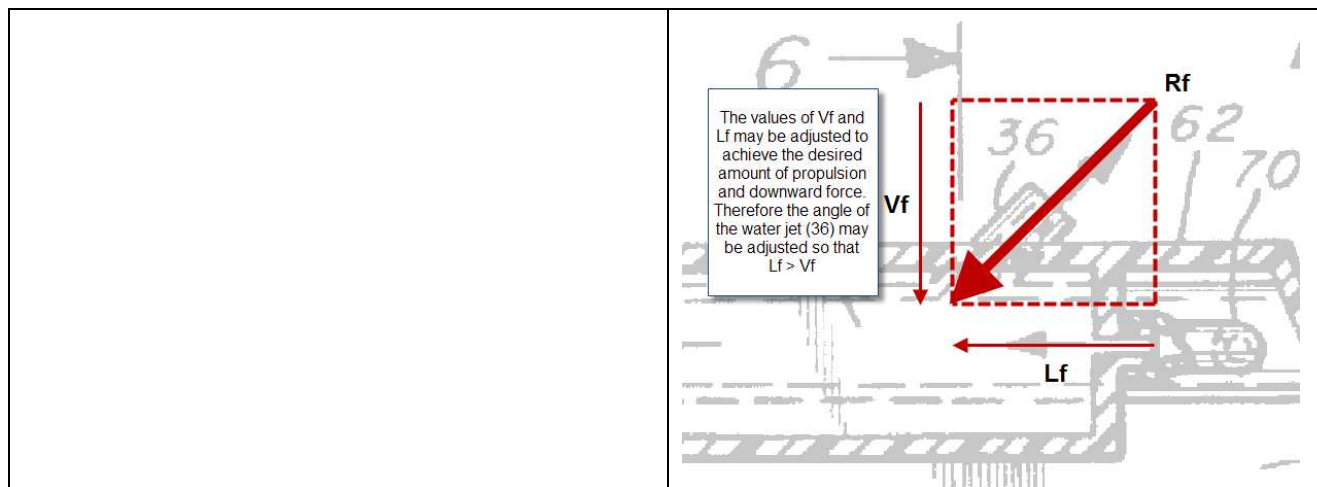
The resultant force vector is directed to pass through the plane of the axis of rotation of the pair of wheels (38A) at the front portion of the apparatus, as depicted below in reference Figure 4:



**I. Claim 9 (Dependent)**

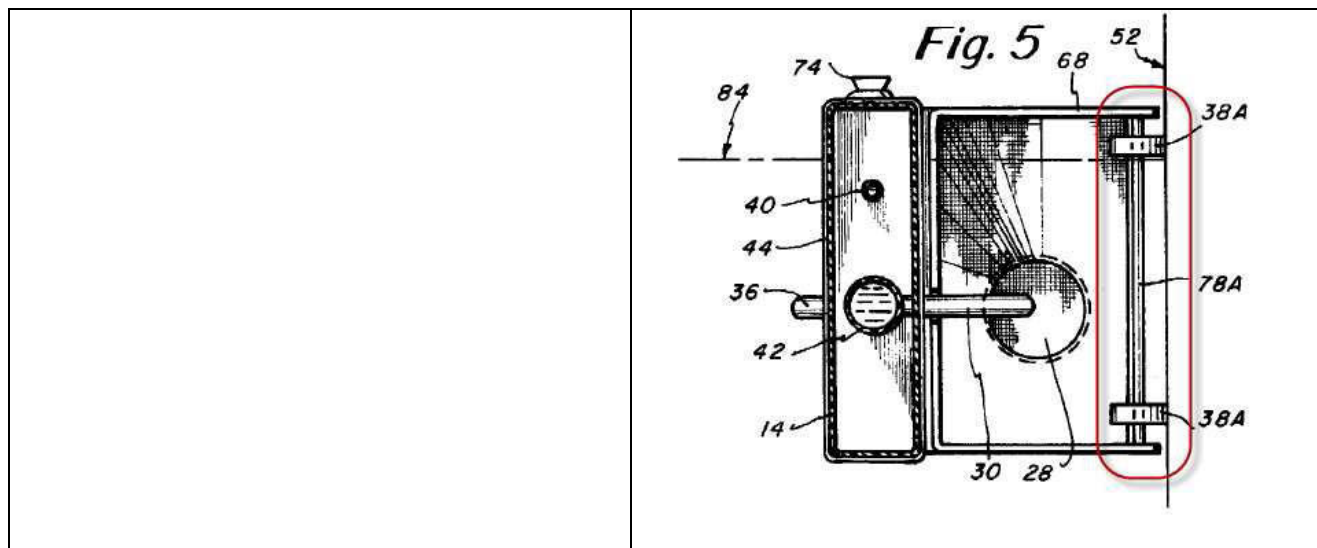
<i>Claim 9</i>	<i>Obvious Over Pansini (Ex. 1003) in View of Myers (Ex. 1001)</i>
The apparatus of claim 8	The combination of Pansini and Myers teaches each of the limitations in claims 1, 7 and 8.
wherein the resultant force vector discharged from said at least one discharge opening includes a longitudinal force vector component and a vertical force vector component, said longitudinal force vector component being aligned with the longitudinal axis of the apparatus and being greater than the vertical force vector component.	<p>Pansini discloses that the resultant force vector (Rf) discharged from the discharge opening (20) includes a longitudinal force vector component (Lf) and a vertical force vector component (Vf), for example, “[t]he described hold-down force is augmented by the angular disposition of the jet nozzles 20 and 22, i.e. each of the drive jets furnishes an additional component of hold-down force to the cleaner.” (Col. 3, l. 66-Col. 4, l. 2).</p> <p>Pansini discloses that the longitudinal force vector component (Lf) is aligned with the longitudinal axis of the apparatus and is greater than the vertical force vector component (Vf), as depicted in reference Figure 4 below:</p>

	
<p><b>Claim 9</b></p>	<p><b>Obvious Over Altschul (Ex. 1004) in View of Myers (Ex. 1001)</b></p>
<p>The apparatus of claim 8</p>	<p>The combination of Altschul and Myers teaches each of the limitations in claims 1, 7 and 8.</p>
<p>wherein the resultant force vector discharged from said at least one discharge opening includes a longitudinal force vector component and a vertical force vector component, said longitudinal force vector component being aligned with the longitudinal axis of the apparatus and being greater than the vertical force vector component.</p>	<p>Altschul discloses that the resultant force vector (Rf) discharged from the discharge opening (36) includes a longitudinal force vector component (Lf) and a vertical force vector component (Vf), for example, “[w]ater jets 26A, 26B and 36 preferably are swivel-type jets which may be adjusted to alter the position of travel of the device, there varying the propulsion and scrubbing characteristics of the device.” (Col. 5, ll. 64-68).</p> <p>Altschul discloses that “[t]he jets can be adjusted to vary propulsion speed, scrubbing force of the brushes, and the like.” (Col. 5, l. 68-Col. 6, l. 2). Accordingly, it would have been obvious to one of ordinary skill in the art to adjust the angle of the jet (36) so that the resultant force vector has a longitudinal force vector component (Lf) that is greater than the vertical force vector component (Vf).</p>



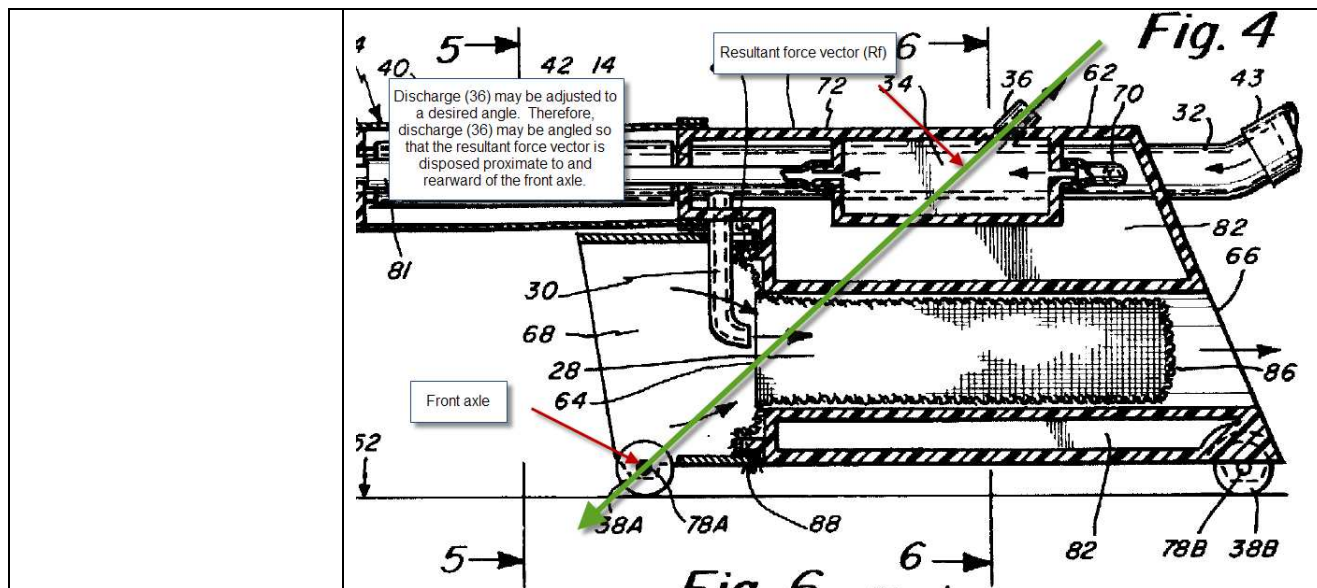
**J. Claim 10 (Dependent)**

<i>Claim 10</i>	<i>Obvious Over Altschul (Ex. 1004) in View of Myers (Ex. 1001)</i>
The apparatus of claim 7,	The combination of Altschul and Myers teaches each of the limitations in claims 1 and 7.
wherein each pair of wheels is mounted on an axle extending transversely across the housing of the apparatus.	Altschul discloses that each pair of wheels (38A, 38B) is mounted on an axle (78A, 78B) extending transversely across the housing of the apparatus, for example, “[a] leading wheel set comprised of two wheels 38A mounted on an axle 78A is supported at the front end of the filtration chamber sleeve 68. A trailing wheel set comprised of two wheels 38B mounted on an axle 78B is supported at the rear end of the trailing portion casing 62.” (Col. 4, l. 67- Col. 5, l. 3). Figures 4 and 5 below, depict the wheels arranged so that the axles (78A, 78B) extend across the housing:

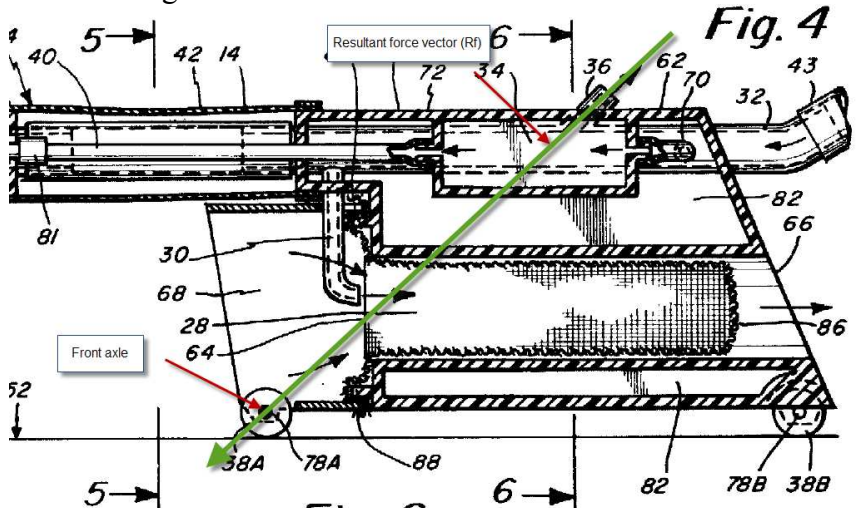


**K. Claim 11 (Dependent)**

<i>Claim 11</i>	<i>Obvious Over Altschul (Ex. 1004) in View of Myers (Ex. 1001)</i>
<p>The apparatus of claim 10,</p>	<p>The combination of Altschul and Myers teaches each of the limitations in claims 1, 7 and 10.</p>
<p>wherein a portion of discharge conduit adjacent the at least one discharge opening is angled upwardly with respect to the discharge conduit to produce a resultant force vector in the water jet discharged from said at least one discharge opening that is directed to a position that is proximate to, and rearwardly displaced from the axle of the front pair of wheels.</p>	<p>Altschul discloses that a portion of discharge conduit (32) adjacent the discharge opening (36) is angled upwardly with respect to the discharge conduit (32) to produce a resultant force vector in the water jet discharged from the discharge opening (36), for example, “[t]he force of the water rushing out of the water propulsion jets [36] propels the pool cleaner in a forward direction while urging the device against the sidewall 52 of the swimming pool.” (Col. 5, ll. 55-58).</p> <p>Altschul discloses that “[t]he jets can be adjusted to vary propulsion speed, scrubbing force of the brushes, and the like.” (Col. 5, l. 68-Col. 6, l. 2). Therefore, it would have been obvious to one of ordinary skill in the art to adjust the angle of the discharge opening (36) so that the resultant force vector is directed to a position that is proximate to, and rearwardly displaced from the axle of the front pair of wheels (38A).</p>

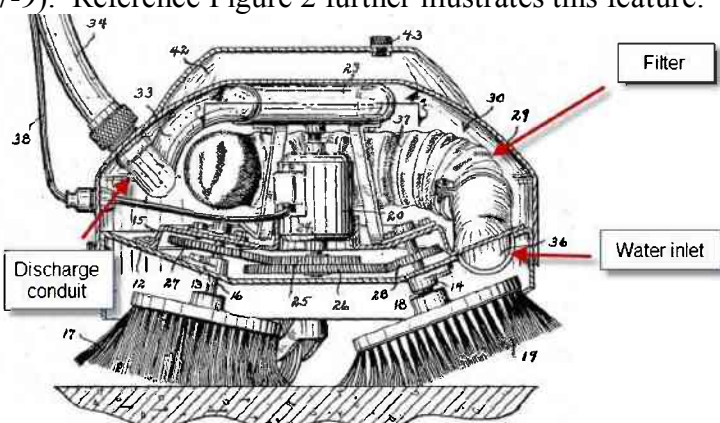


**L. Claim 12 (Dependent)**

<i>Claim 12</i>	<i>Obvious Over Altschul (Ex. 1004) in View of Myers (Ex. 1001)</i>
The apparatus of claim 10,	The combination of Altschul and Myers teaches each of the limitations in claims 1, 7 and 10.
wherein a portion of the discharge conduit terminating adjacent the at least one discharge opening is angled upwardly with respect to the discharge conduit to produce a resultant force vector in the water jet discharged that is directed to intersect the axle of the front pair of wheels.	Altschul discloses that a portion of the discharge conduit (32) terminating adjacent the discharge opening (36) is angled upwardly with respect to the discharge conduit (32) to produce a resultant force vector in the water jet discharged that is directed to intersect the axle of the front pair of wheels (38A), as depicted in reference Figure 4 below: 

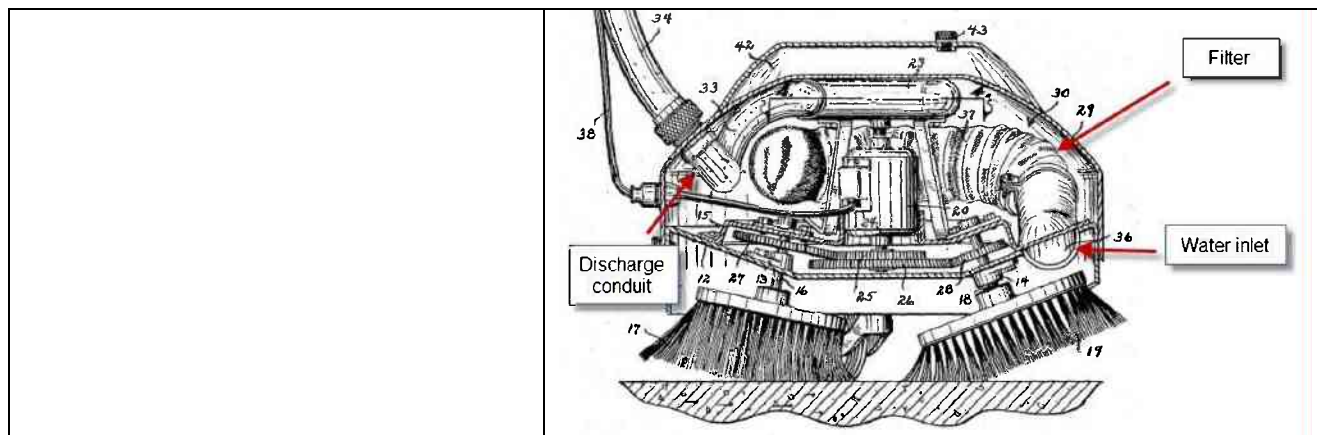


**M. Claim 13 (Dependent)**

<i>Claim 13</i>	<i>Anticipated By Myers (Ex. 1001)</i>
The apparatus of claim 1	Myers discloses each of the limitations recited in independent claim 1.
further comprising at least one filter assembly positioned to filter water from the at least one water inlet prior to its passage through the directional discharge conduit.	<p>Myers discloses that the cleaner includes a filter assembly (37) positioned to filter water from the water inlet (36) prior to its passage through the directional discharge conduit (33), for example, “[w]ater is drawn through the “passageway [36] in the bottom of the compartment 30 . . . . Detachably secured to this passageway 36 is a pocket-type noncollapsible filter 37. This filter is inside the compartment and its porous wall permits water to pass through . . . .” (Col. 2, ll. 22-28). “[T]he filter will be attached to catch the foreign matter and with the elongated conduit [hose] removed the cleaned water will be exited back into the pool.” (Col. 3, ll. 26-32). Water passing through the filter “exit[s] from the unit and into the pool [and] provide[s] a jet force to move the unit.” (Col. 3, ll. 7-9). Reference Figure 2 further illustrates this feature:</p> 

**N. Claim 14 (Dependent)**

<i>Claim 14</i>	<i>Anticipated By Myers (Ex. 1001)</i>
The apparatus of claim 13,	Myers discloses each of the limitations recited in claims 1 and 13.
wherein the at least one filter assembly is mounted within the housing of the cleaning apparatus.	Myers discloses that the filter assembly (37) is mounted within the housing (29) of the cleaning apparatus, as depicted in reference Figure 2 below:

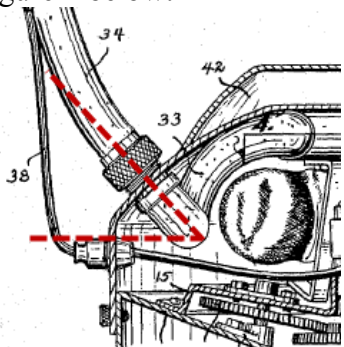
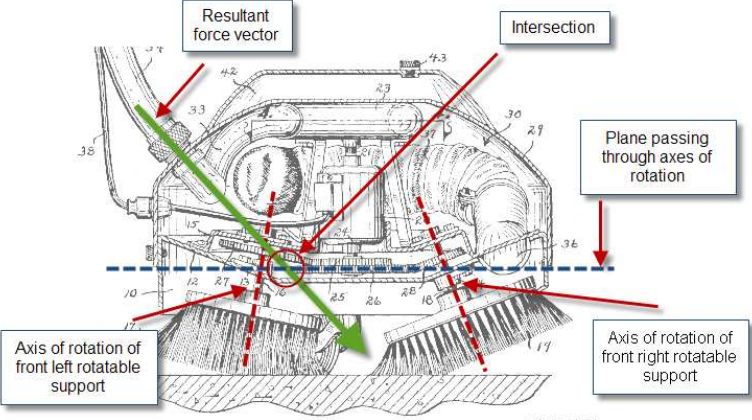


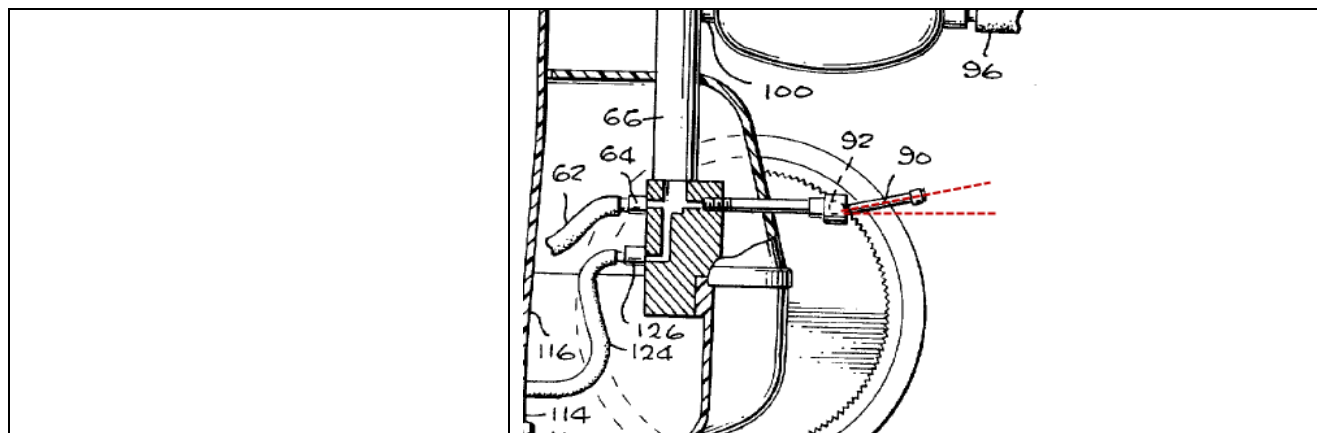
**O. Claim 16 (Dependent)**

<i>Claim 16</i>	<i>Anticipated By Myers (Ex. 1001)</i>
The apparatus of claim 1,	Myers discloses each of the limitations recited in independent claim 1.
wherein water drawn into the at least one water inlet flows through a filter prior to its discharge as the water jet to propel the pool cleaner in a forward direction of movement.	Myers discloses that water drawn into the water inlet (36) flows through a filter (37) prior to its discharge as the water jet to propel the pool cleaner in a forward direction of movement, for example, “[w]ater is drawn through the “passageway [36] in the bottom of the compartment 30 . . . Detachably secured to this passageway 36 is a pocket-type noncollapsible filter 37. This filter is inside the compartment and its porous wall permits water to pass through . . . .” (Col. 2, ll. 22-28). “[T]he filter will be attached to catch the foreign matter and with the elongated conduit [hose] removed the cleaned water will be exited back into the pool.” (Col. 3, ll. 26-32). Water passing through the filter “exit[s] from the unit and into the pool [and] provide[s] a jet force to move the unit.” (Col. 3, ll. 7-9).

**P. Claim 19 (Dependent)**

<i>Claim 19</i>	<i>Anticipated By Myers (Ex. 1001)</i>
The apparatus of claim 1,	Myers discloses each of the limitations recited in independent claim 1.
wherein a portion of the discharge conduit terminating in the at least one discharge opening is fixed at a	Myers discloses that a portion of the discharge conduit (33) terminating in the discharge opening is fixed at a predetermined upward angle with respect to the surface over

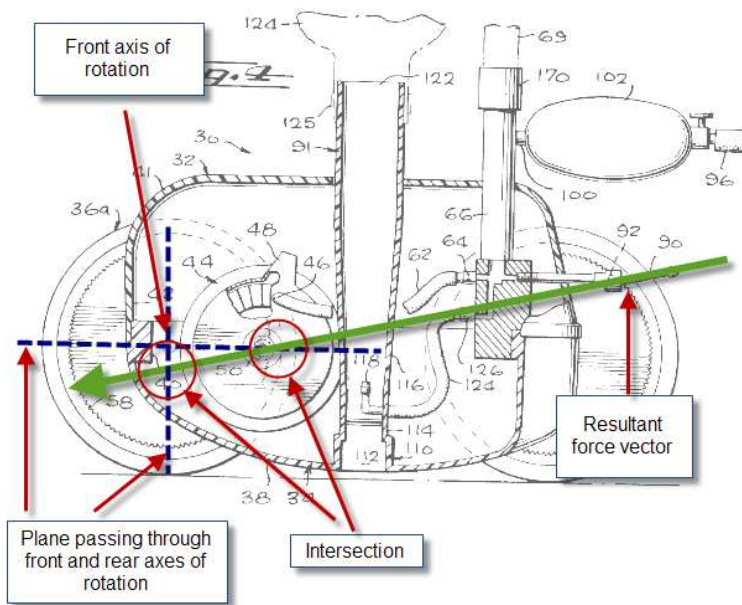
<p>predetermined upward angle with respect to the surface over which the apparatus is moving,</p>	<p>which the apparatus is moving, as depicted in reference Figure 2 below:</p> 
<p>wherein the water jet discharged produces a resultant force vector that crosses a plane passing through the axes of rotation of the front rotationally-mounted supports.</p>	<p>Myers discloses that the water jet discharged produces a resultant force vector, for example, “the water exiting from the unit and into the pool will <b>provide a jet force to move the unit.</b>” (Col. 3, ll. 6-9) (emphasis added).</p> <p>The resultant force vector crosses a plane passing through the axes of rotation of the front rotationally-mounted supports, as depicted in reference Figure 2 below:</p> 
<p><b>Claim 19</b></p>	<p><b>Obvious Over Henkin (Ex. 1002) in View of Myers (Ex. 1001)</b></p>
<p>The apparatus of claim 1,</p>	<p>The combination of Henkin and Myers teaches each of the limitations in independent claim 1.</p>
<p>wherein a portion of the discharge conduit terminating in the at least one discharge opening is fixed at a predetermined upward angle with respect to the surface over which the apparatus is moving,</p>	<p>Henkin discloses that a portion of the discharge conduit (90) terminating in the discharge opening is fixed at a predetermined upward angle with respect to the surface over which the apparatus is moving, as depicted in reference Figure 4 below:</p>



wherein the water jet discharged produces a resultant force vector that crosses a plane passing through the axes of rotation of the front rotationally-mounted supports.

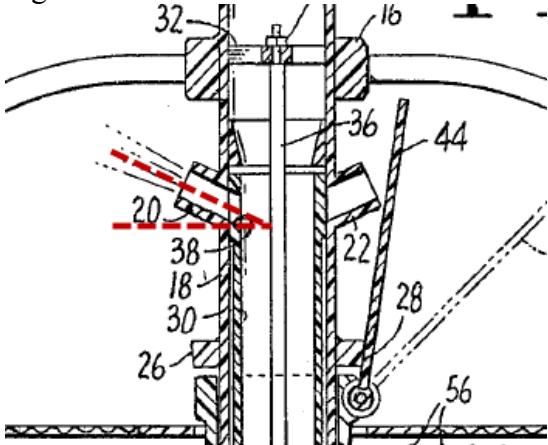
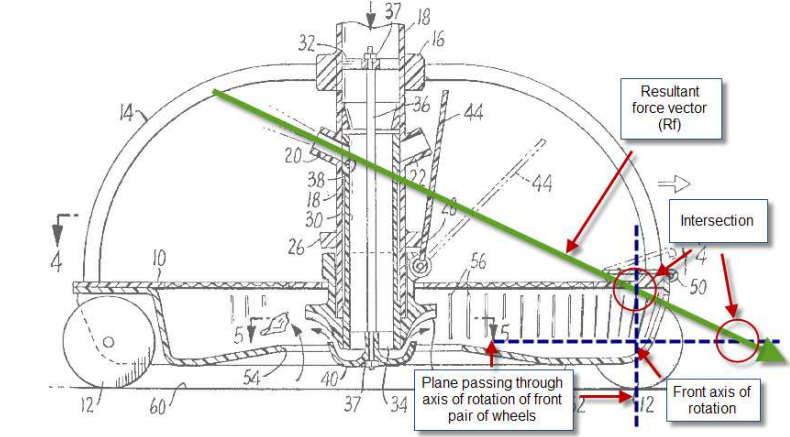
Henkin discloses that the water jet discharged produces a resultant force vector, for example, “thrust is produced by a water jet discharged from a directionally adjustable nozzle 90.” (Col. 5, ll. 6-10).

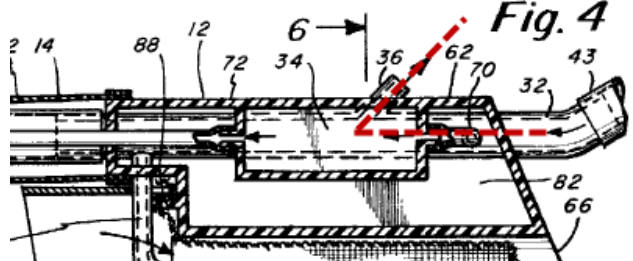
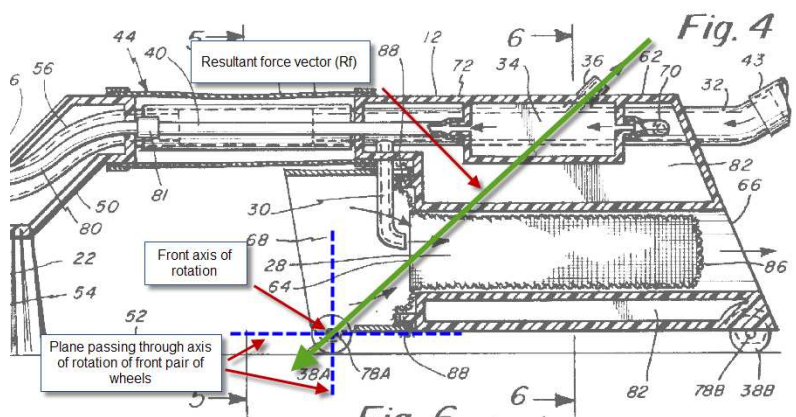
The resultant force vector crosses a plane passing through the axes of rotation of the front rotationally-mounted supports (36A), as depicted in reference Figure 4 below:



<b>Claim 19</b>	<b><i>Obvious Over Pansini (Ex. 1003) in View of Myers (Ex. 1001)</i></b>
-----------------	---

The apparatus of claim 1,	The combination of Pansini and Myers teaches each of the limitations in independent claim 1.
---------------------------	--

<p>wherein a portion of the discharge conduit terminating in the at least one discharge opening is fixed at a predetermined upward angle with respect to the surface over which the apparatus is moving,</p>	<p>Pansini discloses that a portion of the discharge conduit (20) terminating in the discharge opening is fixed at a predetermined upward angle with respect to the surface over which the apparatus is moving, as depicted in reference Figure 3 below:</p> 
<p>wherein the water jet discharged produces a resultant force vector that crosses a plane passing through the axes of rotation of the front rotationally-mounted supports.</p>	<p>Pansini discloses that the water jet discharged produces a resultant force vector, for example, “[t]he described hold-down force is augmented by the angular disposition of the jet nozzles 20 and 22, i.e. each of the drive jets furnishes an additional component of hold-down force to the cleaner.” (Col. 3, l. 66-Col. 4, l. 2).</p> <p>The resultant force vector crosses a plane passing through the axes of rotation of the front rotationally-mounted supports (12), as depicted in reference Figure 3 below:</p> 
<p><b>Claim 19</b></p>	<p><b>Obvious Over Altschul (Ex. 1004) in View of Myers (Ex. 1001)</b></p>
<p>The apparatus of claim 1,</p>	<p>The combination of Altschul and Myers teaches each of the limitations in independent claim 1.</p>

<p>wherein a portion of the discharge conduit terminating in the at least one discharge opening is fixed at a predetermined upward angle with respect to the surface over which the apparatus is moving,</p>	<p>Altschul discloses that a portion of the discharge conduit (36) terminating in the discharge opening is fixed at a predetermined upward angle with respect to the surface over which the apparatus is moving, as depicted in reference Figure 4 below:</p> 
<p>wherein the water jet discharged produces a resultant force vector that crosses a plane passing through the axes of rotation of the front rotationally-mounted supports.</p>	<p>Altschul discloses that the water jet discharged produces a resultant force vector, for example, “[t]he force of the water rushing out of the water propulsion jets propels the pool cleaner in a forward direction while urging the device against the sidewall 52 of the swimming pool.” (Col. 5, ll. 55-58).</p> <p>The resultant force vector crosses a plane passing through the axes of rotation of the front rotationally-mounted supports (38A), as depicted in reference Figure 4 below:</p> 

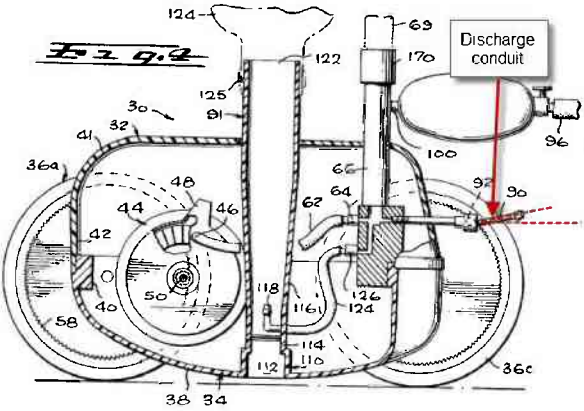
**Q. Claim 20 (Independent)**

<i>Claim 20</i>	<i>Anticipated By Myers (Ex. 1001)</i>
<p>A self-propelled cleaning apparatus for cleaning a submerged surface of a pool or tank, said apparatus being propelled by the discharge of a water jet, the apparatus comprising:</p>	<p>Myers discloses a self-propelled cleaning apparatus for cleaning a submerged surface of a pool or tank. For example, Myers describes that “[t]his invention relates to a swimming pool cleaning device and more particularly to a cleaning means that is erratically self-propelled</p>

	over the bottom surface of the swimming pool.” (Col. 1, ll. 8-11). When the cleaner is configured to use the motor (20) as a pump, then conduit (34) is disconnected from the cleaner and “the water exiting from the unit and into the pool will provide a jet force to move the unit.” (Col. 3, ll. 6-9).
a housing including a baseplate with at least one water inlet, a front portion, a rear portion and opposing side portions defining the periphery of the apparatus, said front portion being defined with respect to the forward directional movement of the apparatus when propelled by the water jet;	Myers discloses a housing (29) including a baseplate with a water inlet (36), a front portion, a rear portion and opposing side portions defining the periphery of the apparatus. (Figs. 1 & 2).
rotationally-mounted supports coupled to the housing to enable movement of said apparatus over the submerged surface;	Myers discloses rotationally-mounted supports (19) coupled to the housing (29) to enable movement. (Col. 2, ll. 55-59).
a water pump mounted in the interior of said housing, said water pump configured to draw water and debris from the pool or tank through the at least one water inlet for filtering, and a pump discharge outlet for emitting a pressurized stream of filtered water;	Myers discloses a water pump (23) mounted in the interior of the housing (29), said water pump being configured to draw water and debris from the pool or tank through the water inlet (36) for filtering. (Col. 2, ll. 8-11, 22-28). Myers also discloses a pump discharge (32) for emitting a pressurized stream of filtered water. (Col. 2, ll. 8-13; Col. 3, ll. 6-9).
a directional discharge conduit in fluid communication with the pump discharge outlet, the discharge conduit having at least one discharge opening through which the water jet is directionally discharged from the apparatus at a predetermined angle that is less than normal with respect to the surface beneath the apparatus.	Myers discloses a directional discharge conduit (33) in fluid communication with the pump discharge outlet (32), the discharge conduit (33) having at least one discharge opening through which the water jet is directionally discharged from the apparatus at a predetermined angle that is less than normal with respect to the surface beneath the apparatus, as depicted in reference Figure 2, below:

<p><b>Claim 20</b></p>	<p><b><i>Obvious Over Henkin (Ex. 1002) in View of Myers (Ex. 1001)</i></b></p>
<p>A self-propelled cleaning apparatus for cleaning a submerged surface of a pool or tank, said apparatus being propelled by the discharge of a water jet, the apparatus comprising:</p>	<p>Henkin discloses a self-propelled cleaning apparatus for cleaning a submerged surface of a pool or tank – that is propelled by the discharge of a water jet. For example, Henkin describes that “[t]he car wheels are driven by a water powered turbine to propel the car in a forward direction, along the vessel surface.” (Abstract).</p>
<p>a housing including a baseplate with at least one water inlet, a front portion, a rear portion and opposing side portions defining the periphery of the apparatus, said front portion being defined with respect to the forward directional movement of the apparatus when propelled by the water jet;</p>	<p>Henkin discloses a housing (32) having a baseplate (38) with a water inlet (112), a front portion, a rear portion and opposing side portions defining the periphery of the apparatus. (Figs. 4 &amp; 5).</p>
<p>rotationally-mounted supports coupled to the housing to enable movement of said apparatus over the submerged surface;</p>	<p>Henkin discloses rotationally-mounted supports (36A, 36B, 36C) coupled to the housing (32) to enable movement. (Col. 5, ll.28-29).</p>
<p>a water pump mounted in the interior of said housing, said water pump configured to draw water and debris from the pool or tank through the at least one water inlet for filtering, and a pump discharge outlet for emitting a pressurized stream of filtered water;</p>	<p>Henkin discloses that an external pump (70) provides high pressure flow to the cleaner via a supply hose (69). (Col. 4, ll. 35-41). The pressurized water is discharged from the orifice (118) to produce a suction at the entrance of the water inlet (112), which causes water and debris to be drawn from the pool into the water inlet (112) and through a filter (124). (Col. 6, ll. 20-34). A portion of the pressurized water is emitted through nozzle (90). (Col. 5, ll. 15-18).</p> <p>Henkin teaches that to prevent entanglement of the pool cleaner with the supply hose (69), the hose includes floats and swivel couplings (164,</p>

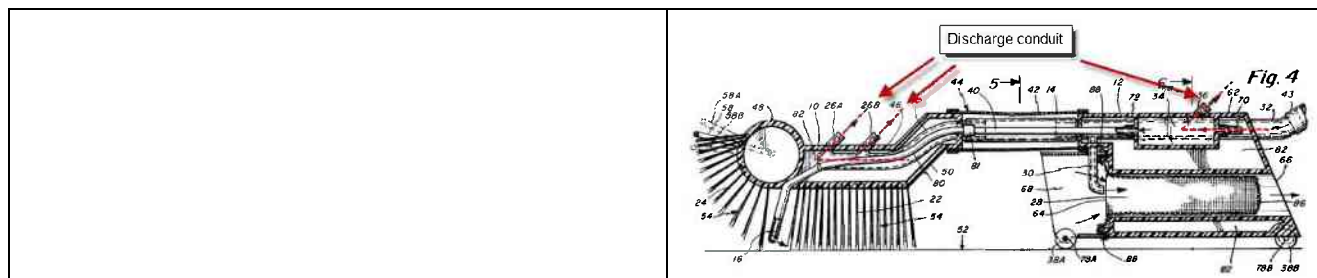


	<p>170). (Col. 6, ll. 37-52).</p> <p>Myers discloses a water pump mounted in the interior housing of a pool cleaner, used to draw water and debris from the pool through a water inlet for filtering. (Col. 2, ll. 8-11).</p> <p>It would have been obvious to one of ordinary skill in the art to combine the internally mounted pump of Myers with Henkin to eliminate the need for an external source of pressurized water, a supply hose, and the need to manage the supply hose in order to prevent entanglement.</p>
<p>a directional discharge conduit in fluid communication with the pump discharge outlet, the discharge conduit having at least one discharge opening through which the water jet is directionally discharged from the apparatus at a predetermined angle that is less than normal with respect to the surface beneath the apparatus.</p>	<p>Henkin discloses a directional discharge conduit (90) in fluid communication with the pump discharge outlet, the discharge conduit (90) having at least one discharge opening through which the water jet is directionally discharged from the apparatus at a predetermined angle that is less than normal with respect to the surface beneath the apparatus. (Col. 5, ll. 6-10, 15-24).</p> 
<p><b>Claim 20</b></p>	<p><b>Obvious Over Pansini (Ex. 1003) in View of Myers (Ex. 1001)</b></p>
<p>A self-propelled cleaning apparatus for cleaning a submerged surface of a pool or tank, said apparatus being propelled by the discharge of a water jet, the apparatus comprising:</p>	<p>Pansini discloses a self-propelled cleaning apparatus for cleaning a submerged surface of a pool or tank – that is propelled by the discharge of a water jet. For example, Pansini describes “[a] jet-powered submerged cleaner runs along the bottom of a pool and also up and down the side walls.” (Abstract).</p>
<p>a housing including a baseplate with at least one water inlet, a front portion, a rear portion and</p>	<p>Pansini discloses a housing (10) having a baseplate (52) with a water inlet (54), a front</p>

opposing side portions defining the periphery of the apparatus, said front portion being defined with respect to the forward directional movement of the apparatus when propelled by the water jet;	portion, a rear portion and opposing side portions defining the periphery of the apparatus. (Figs. 1 & 3).
rotationally-mounted supports coupled to the housing to enable movement of said apparatus over the submerged surface;	Pansini discloses rotationally-mounted supports (12) coupled to the housing. (Col. 2, ll. 41-44).
a water pump mounted in the interior of said housing, said water pump configured to draw water and debris from the pool or tank through the at least one water inlet for filtering, and a pump discharge outlet for emitting a pressurized stream of filtered water;	<p>Pansini discloses that a flexible hose (48) is attached to the cleaner at one end (18), extends to the surface, and connects to an external pump at the opposite end to deliver pressurized water to the cleaner. (Col. 2: ll. 61-65). The pressurized water produces a suction at the entrance of the water inlet (54), which causes water and debris to be drawn from the pool into the water inlet (54) and through a filtration compartment. (Col. 3, ll. 19-27). A portion of the pressurized water is emitted through water jet (20). (Col. 3, ll. 12-13; Fig. 3).</p> <p>Myers discloses a water pump mounted in the interior housing of a pool cleaner, used to draw water and debris from the pool through a water inlet for filtering. (Col. 2, ll. 8-11).</p> <p>It would have been obvious to one of ordinary skill in the art to combine the internally mounted pump of Myers with Pansini to eliminate the need for an external source of pressurized water and a supply hose.</p>
a directional discharge conduit in fluid communication with the pump discharge outlet, the discharge conduit having at least one discharge opening through which the water jet is directionally discharged from the apparatus at a predetermined angle that is less than normal with respect to the surface beneath the apparatus.	Pansini discloses a directional discharge conduit (20, 22) in fluid communication with the pump discharge outlet, the discharge conduit (20, 22) having at least one discharge opening through which the water jet is directionally discharged from the apparatus at a predetermined angle that is less than normal with respect to the surface beneath the apparatus. (Col. 3, ll. 12-13; Col. 5, ll. 26-27; Fig. 3).

<p style="text-align: center;"><b>Claim 20</b></p>	<p style="text-align: center;"><b>Obvious Over Altschul (Ex. 1004) in View of Myers (Ex. 1001)</b></p>
<p>A self-propelled cleaning apparatus for cleaning a submerged surface of a pool or tank, said apparatus being propelled by the discharge of a water jet, the apparatus comprising:</p>	<p>Altschul discloses a self-propelled cleaning apparatus for cleaning a submerged surface of a pool or tank – that is propelled by the discharge of a water jet. For example, Altschul describes “[a] device for cleaning the sidewalls of a swimming pool at the waterline region is self-propelled by water jets which also urge the device against the pool sidewall.” (Abstract).</p>
<p>a housing including a baseplate with at least one water inlet, a front portion, a rear portion and opposing side portions defining the periphery of the apparatus, said front portion being defined with respect to the forward directional movement of the apparatus when propelled by the water jet;</p>	<p>Altschul discloses a housing having a baseplate (88) with a water inlet (64), a front portion (10), a rear portion (12) and opposing side portions defining the periphery of the apparatus. (Figs. 1 &amp; 4).</p>
<p>rotationally-mounted supports coupled to the housing to enable movement of said apparatus over the submerged surface;</p>	<p>Altschul discloses rotationally-mounted supports (38A, 38B) coupled to the housing. (Col. 4, l. 67-Col. 5, l. 3).</p>
<p>a water pump mounted in the interior of said housing, said water pump configured to draw water and debris from the pool or tank through the at least one water inlet for filtering, and a pump discharge outlet for emitting a pressurized stream of filtered water;</p>	<p>Altschul discloses that a flexible hose (43) is connected to the cleaner at main inlet tube (32) at one end, and a source of pressurized water at the other end. “The hose 43 has one or more floats 45 which keep the hose 43 afloat so as not to drag downwardly on the device.” (Col. 4, ll. 8-22). A portion of the pressurized water flows through “the elongated water propulsion jet 30 [and] is directed rearward through the filtration chamber 28. Thus, not only does the flow from the elongated water propulsion jet 30 assist in propelling the device in a forward direction, it also creates a suction effect as the device travels through the water whereby water tends to be</p>

	<p>drawn into the filtration chamber 28 through the filtration chamber entrance 64 and out the filtration chamber exit 66.” (Col. 6, ll. 18-27). Debris loosened by the brush portions (22, 24) is drawn into the filtration chamber (28) where the dirt may be filtered from the water by the filtration bag (86). (Col. 6, ll. 27-32). A portion of the pressurized water is emitted through propulsion jets (26A, 26B, 36). (Col. 5, ll. 46-58).</p> <p>Myers discloses a water pump mounted in the interior housing of a pool cleaner, used to draw water and debris from the pool through a water inlet for filtering. (Col. 2, ll. 8-11). Brushes (19) scrub the pool floor, causing debris to be loosened and drawn into the filter. (Col. 2, ll. 63-66; Col. 3, ll. 35-37).</p> <p>Both Altschul and Myers thus disclose a self-propelled pool cleaner that uses pressurized water to propel the cleaner, draw water through an inlet for filtering, and a brush element to scrub a pool surface to remove debris. Therefore, it would have been obvious to one of ordinary skill in the art to combine the internally mounted pump of Myers with Altschul to eliminate the need for an external source of pressurized water and a supply hose.</p>
<p>a directional discharge conduit in fluid communication with the pump discharge outlet, the discharge conduit having at least one discharge opening through which the water jet is directionally discharged from the apparatus at a predetermined angle that is less than normal with respect to the surface beneath the apparatus.</p>	<p>Altschul discloses a directional discharge conduit (26A, 26B, 36) in fluid communication with the pump discharge outlet, the discharge conduit (26A, 26B, 36) having at least one discharge opening through which the water jet is directionally discharged from the apparatus at a predetermined angle that is less than normal with respect to the surface beneath the apparatus. (Col. 5, ll. 46-60).</p>



**R. Claim 21 (Independent)**

<i>Claim 21</i>	<i>Anticipated By Myers (Ex. 1001)</i>
A method for cleaning a submerged surface of a pool or tank, comprising the steps of:	Myers discloses a method for cleaning a submerged surface of a pool or tank. (Col. 1, ll. 8-11).
providing a self-propelled cleaning apparatus, said cleaning apparatus including a housing having a baseplate with at least one water inlet, and further including a front portion as defined by the direction of movement of the cleaning apparatus when propelled by a water jet, an opposing rear portion and adjoining side portions defining the periphery of the apparatus,	Myers discloses providing a self-propelled cleaning apparatus, said cleaning apparatus including a housing having (29) a baseplate with a water inlet (36), a front portion, an opposing rear portion and adjoining side portions defining the periphery of the apparatus. (Figs. 1 & 2).
rotationally-mounted supports coupled to the housing to enable movement of said apparatus over the submerged surface,	Myers discloses rotationally-mounted supports (19) coupled to the housing (29) to enable movement of said apparatus over the submerged surface. (Col. 2, ll. 55-59).
a water pump mounted in the interior of said housing, and	Myers discloses a water pump (23) mounted in the interior of the housing (29). (Col. 2, ll. 8-11, 22-28).
a directional discharge conduit in fluid communication with the water pump and having at least one discharge opening;	Myers discloses a directional discharge conduit (33) in fluid communication with the water pump and having at least one discharge opening. (Col. 2, ll. 8-13; Col. 3, ll. 6-9; Fig. 1).
activating the water pump to draw water and debris from the pool or tank through the at least one water inlet;	Myers discloses activating the water pump (23) to draw water and debris from the pool or tank through the at least one water inlet (36), for example, “[i]n [] compartment [30] is the pump-motor 23 having the usual inlet opening 31 and outlet opening 32. The inlet opening 31 communicates with the inside of the compartment 30.” (Col. 2, ll. 8-11). Water is drawn through the “passageway [36] in the bottom of the compartment 30 . . . .” (Col. 2, ll.

	22-23).
filtering the water drawn into the housing;	Myers discloses filtering the water drawn into the housing, for example, “[d]etachably secured to this passageway 36 is a pocket-type noncollapsible filter 37. This filter is inside the compartment and its porous wall permits water to pass through . . . .” (Col. 2, ll. 26-28).
discharging the filtered water through the directional discharge conduit at an acute angle with respect to the surface over which the apparatus is moving,	Myers discloses discharging the filtered water through the directional discharge conduit (33), for example, water passing through the filter “exit[s] from the unit and into the pool [and] provide[s] a jet force to move the unit.” (Col. 3, ll. 7-9).  Myers discloses that the discharge conduit is at an acute angle with respect to the surface over which the apparatus is moving. (Fig. 2).
said discharged filtered water forming a water jet having a resultant force vector acutely angled towards the surface beneath the apparatus; and	Myers discloses that the discharged filtered water forms a water jet having a resultant force vector acutely angled towards the surface beneath the apparatus, for example, water passing through the filter “exit[s] from the unit and into the pool [and] provide[s] a jet force to move the unit.” (Col. 3, ll. 7-9; Fig. 2).
propelling the apparatus in a forward direction of movement.	Myers discloses propelling the apparatus in a forward direction of movement. (Col. 3, ll. 7-9).
<b><i>Claim 21</i></b>	<b><i>Obvious Over Henkin (Ex. 1002) in View of Myers (Ex. 1001)</i></b>
A method for cleaning a submerged surface of a pool or tank, comprising the steps of:	Henkin discloses a method for cleaning a submerged surface of a pool or tank. (Abstract).
providing a self-propelled cleaning apparatus, said cleaning apparatus including a housing having a baseplate with at least one water inlet, and further including a front portion as defined by the direction of movement of the cleaning apparatus when propelled by a water jet, an opposing rear portion and adjoining side portions defining the periphery of the apparatus,	Henkin discloses providing a self-propelled cleaning apparatus, said cleaning apparatus including a housing having (32) a baseplate (38) with a water inlet (112), a front portion, an opposing rear portion and adjoining side portions defining the periphery of the apparatus. (Figs. 4 & 5).
rotationally-mounted supports coupled to the housing to enable movement of said apparatus over the submerged surface,	Henkin discloses rotationally-mounted supports (36A, 36B, 36C) coupled to the housing (32) to enable movement of said apparatus over the submerged surface. (Col. 5, ll.28-29).
a water pump mounted in the interior of said	Henkin discloses that an external pump (70)

housing, and	<p>provides high pressure flow to the cleaner via a supply hose (69). (Col. 4, ll. 35-41).</p> <p>Henkin teaches that to prevent entanglement of the pool cleaner with the supply hose (69), the hose includes floats and swivel couplings (164, 170). (Col. 6, ll. 37-52).</p> <p>Myers discloses a water pump mounted in the interior housing of a pool cleaner. (Col. 2, ll. 8-11).</p> <p>It would have been obvious to one of ordinary skill in the art to combine the internally mounted pump of Myers with Henkin to eliminate the need for an external source of pressurized water, a supply hose, and the need to manage the supply hose in order to prevent entanglement.</p>
a directional discharge conduit in fluid communication with the water pump and having at least one discharge opening;	Henkin discloses a directional discharge conduit (90) in fluid communication with the water pump and having at least one discharge opening. (Col. 5, ll. 15-18).
activating the water pump to draw water and debris from the pool or tank through the at least one water inlet;	Henkin discloses activating the water pump to draw water and debris from the pool or tank through the at least one water inlet (112), for example, pressurized water is discharged from the orifice (118) to produce a suction at the entrance of the water inlet (112), which causes water and debris to be drawn from the pool into the water inlet (112) and through a filter (124). (Col. 6, ll. 20-34).
filtering the water drawn into the housing;	Henkin discloses filtering the water drawn into the housing. (Col. 6, ll. 20-34).
discharging the filtered water through the directional discharge conduit at an acute angle with respect to the surface over which the apparatus is moving,	<p>Although Henkin discloses discharging water through a discharge conduit (90) that is positioned at an acute angle, the water is discharged before it is filtered. (Col. 5, ll. 15-18).</p> <p>Myers discloses discharging filtered water through a discharge conduit (33) that is at an acute angle with respect to the surface over which the apparatus is moving. (Col. 3, ll. 7-9; Fig. 2).</p>

	It would have been obvious to one of ordinary skill in the art to configure Henkin with the discharge conduit and filter of Myers, in order to discharge filtered water, rather than unfiltered water.
said discharged filtered water forming a water jet having a resultant force vector acutely angled towards the surface beneath the apparatus; and	Although Henkin discloses discharging water forming a water jet having a resultant force vector acutely angled towards the surface beneath the apparatus, the water jet is not filtered. (Col. 5, ll. 6-10, 15-24).  Myers discloses discharging filtered water forming a water jet having a resultant force vector acutely angled towards the surface beneath the apparatus. (Col. 3, ll. 7-9; Fig. 2).  It would have been obvious to one of ordinary skill in the art to configure Henkin with the discharge conduit and filter of Myers, in order to form a water jet of filtered water, rather than unfiltered water.
propelling the apparatus in a forward direction of movement.	Henkin discloses propelling the apparatus in a forward direction of movement. (Abstract).
<b><i>Claim 21</i></b>	<b><i>Obvious Over Pansini (Ex. 1003) in View of Myers (Ex. 1001)</i></b>
A method for cleaning a submerged surface of a pool or tank, comprising the steps of:	Pansini discloses a method for cleaning a submerged surface of a pool or tank (Abstract).
providing a self-propelled cleaning apparatus, said cleaning apparatus including a housing having a baseplate with at least one water inlet, and further including a front portion as defined by the direction of movement of the cleaning apparatus when propelled by a water jet, an opposing rear portion and adjoining side portions defining the periphery of the apparatus,	Pansini discloses providing a self-propelled cleaning apparatus, said cleaning apparatus including a housing having (10) a baseplate (52) with a water inlet (54), a front portion, an opposing rear portion and adjoining side portions defining the periphery of the apparatus. (Figs. 1 & 3).
rotationally-mounted supports coupled to the housing to enable movement of said apparatus over the submerged surface,	Pansini discloses rotationally-mounted supports (12) coupled to the housing to enable movement of said apparatus over the submerged surface. (Col. 2, ll. 41-44).
a water pump mounted in the interior of said housing, and	Pansini discloses that a flexible hose (48) is attached to the cleaner at one end (18), extends to the surface, and connects to an external pump



	<p>at the opposite end to deliver pressurized water to the cleaner. (Col. 2: ll. 61-65).</p> <p>Myers discloses a water pump mounted in the interior housing of a pool cleaner. (Col. 2, ll. 8-11).</p> <p>It would have been obvious to one of ordinary skill in the art to combine the internally mounted pump of Myers with Pansini to eliminate the need for an external source of pressurized water and a supply hose.</p>
a directional discharge conduit in fluid communication with the water pump and having at least one discharge opening;	Pansini discloses a directional discharge conduit (18) in fluid communication with the water pump and having at least one discharge opening (20). (Col. 3, ll. 12-13; Fig. 3).
activating the water pump to draw water and debris from the pool or tank through the at least one water inlet;	Pansini discloses activating the water pump to draw water and debris from the pool or tank through the at least one water inlet (54), for example, pressurized water produces a suction at the entrance of the water inlet (54), which causes water and debris to be drawn from the pool into the water inlet (54) and through a filtration compartment. (Col. 3, ll. 19-27).
filtering the water drawn into the housing;	Pansini discloses filtering the water drawn into the housing. (Col. 3, ll. 19-27).
discharging the filtered water through the directional discharge conduit at an acute angle with respect to the surface over which the apparatus is moving,	<p>Although Pansini discloses discharging water through a discharge conduit (20) that is positioned at an acute angle, the water is discharged before it is filtered. (Col. 3, ll. 12-13; Col. 5, ll. 26-27; Fig. 3).</p> <p>Myers discloses discharging filtered water through a discharge conduit (33) that is at an acute angle with respect to the surface over which the apparatus is moving. (Col. 3, ll. 7-9; Fig. 2).</p> <p>It would have been obvious to one of ordinary skill in the art to configure Pansini with the discharge conduit and filter of Myers, in order to discharge filtered water, rather than unfiltered water.</p>

<p>said discharged filtered water forming a water jet having a resultant force vector acutely angled towards the surface beneath the apparatus; and</p>	<p>Although Pansini discloses discharging water forming a water jet having a resultant force vector acutely angled towards the surface beneath the apparatus, the water jet is not filtered. (Col. 3, ll. 12-13; Col. 5, ll. 26-27; Fig. 3).</p> <p>Myers discloses discharging filtered water forming a water jet having a resultant force vector acutely angled towards the surface beneath the apparatus. (Col. 3, ll. 7-9; Fig. 2).</p> <p>It would have been obvious to one of ordinary skill in the art to configure Pansini with the discharge conduit and filter of Myers, in order to form a water jet of filtered water, rather than unfiltered water.</p>
<p>propelling the apparatus in a forward direction of movement.</p>	<p>Pansini discloses propelling the apparatus in a forward direction of movement. (Abstract).</p>
<p><b><i>Claim 21</i></b></p>	<p><b><i>Obvious Over Altschul (Ex. 1004) in View of Myers (Ex. 1001)</i></b></p>
<p>A method for cleaning a submerged surface of a pool or tank, comprising the steps of:</p>	<p>Altschul discloses a method for cleaning a submerged surface of a pool or tank (Abstract).</p>
<p>providing a self-propelled cleaning apparatus, said cleaning apparatus including a housing having a baseplate with at least one water inlet, and further including a front portion as defined by the direction of movement of the cleaning apparatus when propelled by a water jet, an opposing rear portion and adjoining side portions defining the periphery of the apparatus,</p>	<p>Altschul discloses providing a self-propelled cleaning apparatus, said cleaning apparatus including a housing having a baseplate (88) with a water inlet (64), a front portion (10), an opposing rear portion (12) and adjoining side portions defining the periphery of the apparatus. (Figs. 1 &amp; 4).</p>
<p>rotationally-mounted supports coupled to the housing to enable movement of said apparatus over the submerged surface,</p>	<p>Altschul discloses rotationally-mounted supports (38A, 38B) coupled to the housing to enable movement of said apparatus over the submerged surface. (Col. 4, l. 67-Col. 5, l. 3).</p>
<p>a water pump mounted in the interior of said housing, and</p>	<p>Altschul discloses that a flexible hose (43) is connected to the cleaner at main inlet tube (32) at one end, and a source of pressurized water at the other end. (Col. 4, ll. 8-22).</p> <p>Myers discloses a water pump mounted in the interior housing of a pool cleaner. (Col. 2, ll. 8-11).</p>

	It would have been obvious to one of ordinary skill in the art to combine the internally mounted pump of Myers with Altschul to eliminate the need for an external source of pressurized water and a supply hose.
a directional discharge conduit in fluid communication with the water pump and having at least one discharge opening;	Altschul discloses a directional discharge conduit (26A, 26B, 36) in fluid communication with the water pump and having at least one discharge opening (26A, 26B, 36). (Col. 5, ll. 46-60).
activating the water pump to draw water and debris from the pool or tank through the at least one water inlet;	Altschul discloses activating the water pump to draw water and debris from the pool or tank through the at least one water inlet (64), for example, a portion of the pressurized water flows through “the elongated water propulsion jet 30 [and] is directed rearward through the filtration chamber 28. Thus, not only does the flow from the elongated water propulsion jet 30 assist in propelling the device in a forward direction, it also creates a suction effect as the device travels through the water whereby water tends to be drawn into the filtration chamber 28 through the filtration chamber entrance 64 and out the filtration chamber exit 66.” (Col. 6, ll. 18-27).
filtering the water drawn into the housing;	Altschul discloses filtering the water drawn into the housing. (Col. 6, ll. 18-27).
discharging the filtered water through the directional discharge conduit at an acute angle with respect to the surface over which the apparatus is moving,	<p>Although Altschul discloses discharging water through a discharge conduit (26A, 26B, 36) that is positioned at an acute angle, the water is discharged before it is filtered. (Col. 5, ll. 46-60; Fig. 4).</p> <p>Myers discloses discharging filtered water through a discharge conduit (33) that is at an acute angle with respect to the surface over which the apparatus is moving. (Col. 3, ll. 7-9; Fig. 2).</p> <p>It would have been obvious to one of ordinary skill in the art to configure Altschul with the discharge conduit and filter of Myers, in order to</p>

	<p>discharge filtered water, rather than unfiltered water.</p>
<p>said discharged filtered water forming a water jet having a resultant force vector acutely angled towards the surface beneath the apparatus; and</p>	<p>Although Altschul discloses discharging water forming a water jet having a resultant force vector acutely angled towards the surface beneath the apparatus, the water jet is not filtered. (Col. 5, ll. 55-58; Fig. 4).</p> <p>Myers discloses discharging filtered water forming a water jet having a resultant force vector acutely angled towards the surface beneath the apparatus. (Col. 3, ll. 7-9; Fig. 2).</p> <p>It would have been obvious to one of ordinary skill in the art to configure Altschul with the discharge conduit and filter of Myers, in order to form a water jet of filtered water, rather than unfiltered water.</p>
<p>propelling the apparatus in a forward direction of movement.</p>	<p>Altschul discloses propelling the apparatus in a forward direction of movement. (Abstract).</p>

Petition for *Inter Partes* Review of U.S. Patent No. 8,273,183

Attorney Docket No.: 084586-0208

## VII. CONCLUSION

For the forgoing reasons, *inter partes* review of claims 1-14, 16, and 19-21 of U.S. Patent No. 8,273,183 is respectfully requested.

Respectfully submitted,

MCDERMOTT WILL & EMERY LLP

/John A. Hankins/

John A. Hankins, Registration No. 32,029  
Eric R. Garcia, Registration No. 69,630  
4 Park Plaza, Suite 1700  
Irvine, CA 92614-2559  
Phone: (949) 851-0633  
Facsimile: (949) 851-9348

**IN THE UNITED STATES PATENT AND TRADEMARK OFFICE**

In the *Inter Partes* Review of:

U.S. Patent No. 8,273,183

Filed: July 12, 2011

Issued: September 25, 2012

Inventors: Giora Erlich et al.

Assignee: Aqua Products, Inc.

For: AUTOMATED SWIMMING POOL  
CLEANER HAVING AN ANGLED  
JET DRIVE PROPULSION SYSTEM

Attorney Docket No.: 222,604

Case No. IPR2013-00159

Panel: Administrative Patent  
Judges Brian McNamara, Rama  
Elluru and James Arpin

**PATENT OWNER'S  
REPLACEMENT  
CORRECTED MOTION TO  
AMEND CLAIMS**

Dated: March 3, 2014

Filed By:  
Jeffrey A. Schwab (Lead Counsel)  
Reg. No. 24,490  
Abelman, Frayne & Schwab  
666 Third Avenue  
New York, New York 10017  
Telephone: (212) 949-9022  
Facsimile: (212) 949-9149  
Email: [jaschwab@lawabel.com](mailto:jaschwab@lawabel.com)

**TABLE OF CONTENTS**

I.	LISTING OF PROPOSED SUBSTITUTE CLAIMS.....	2
	A. Claim Listing .....	2
II.	SUPPORT FOR PROPOSED SUBSTITUTE CLAIMS .....	5
	A. Proposed Substitute Independent Claims 22 and 24.....	5
	B. Proposed Substitute Dependent Claim 23 (Original Claim 8).	6
III.	PATENTABILITY OF PROPOSED SUBSTITUTE CLAIMS...	7
	A. Substitute Claims Are Patentable Over Myers.....	11
	B. Substitute Claims Are Not Obvious In View of Henkin and Myers.....	11
	C. Substitute Claims are Not Obvious in View of Pansini and Myers.....	13
IV.	CONCLUSION.....	15

**EXHIBIT LIST**

The following is a list of Exhibits referred to in this motion:

**Previously Filed**

Exhibit 1001 – U.S. Patent 3,321,787 to Myers

Exhibit 1001 – U.S. Patent 3,936,899 to Henkin

Exhibit 1003 – U.S. Patent 4,100,641 to Pansini

Exhibit 1006 – U.S. Patent No. 8,273,183 to Erlich, et al.

Exhibit 2005 – U.S. Patent No. 5,293,659 to Rief, et al.

Exhibit 2006 – U.S. Patent No. 5,720,068 to Clark, et al.

Exhibit 2007 – U.S. Patent No. 3,291,145 to Arneson

Exhibit 2008 – U.S. Patent No. 3,817,382 to Arneson

Exhibit 2009 – U.S. Patent No. 4,168,557 to Rasch, et al.

Exhibit 2011 – Aqua Products' Order Confirmation No. 720005933

Exhibit 2012 – Aqua Products' Invoice No. 780010095

Exhibit 2013 – Application file history of U.S. Patent 4,100,641 to Pansini

**Currently Filed**

Exhibit 2016 – Corrected Declaration of Giora Erlich In Support of Patent Owner's Second Corrected Motion to Amend Claims and Patent Owner's Response to Petition for *Inter Partes* Review



Aqua Products, Inc. (“Aqua Products” or “Patent Owner”) respectfully submits this Replacement Corrected Motion to Amend Claims of U.S. Patent No. 8,273,183 (“’183 Patent”; Exhibit 1006) pursuant to 37 C.F.R. § 42.121.<sup>1</sup>

The Patent Trial and Appeal Board (“Board”) granted the petition of Zodiac Pool Systems, Inc. (“Zodiac” or “Petitioner”) for *inter partes* review of claims 1–9, 13, 14, 16 and 19–21 of the ‘183 Patent. Decision, Paper 18. The Board denied the Petition with respect to claims 10-12. Petitioner did not seek review of claims 15, 17, or 18. On September 24, 2013, Patent Owner initially advised the Board that it would file a motion to amend claims. The proposed amendments resolve all issues relating to patentability of the claims in question and comply with 37 C.F.R. § 42.121. The amendments respond to the stated grounds of invalidity, do not enlarge the scope of the claims, do not introduce new subject matter and propose a reasonable number of substitute claims. The Corrected Declaration of Giora Erlich, an inventor of the ‘183 Patent, is filed concurrently in support of this motion as Exhibit 2016.

---

<sup>1</sup> Patent Owner filed the First Corrected Motion to Amend Claims seeking to correct certain clerical errors of omission in claims 1, 8 and 20 by the conventional form of claim amendment, i.e., underlining and strikethrough, but was advised by the Board that the proper form required submission of proposed substitute claims. This Replacement Corrected Motion to Amend Claims is submitted pursuant to the Board’s instruction (which was conveyed during telephone conferences with counsel for the Petitioner and Patent Owner held on February 25, 2014 and February 28, 2014 and the Order dated February 27, 2014 (Paper 40)).

**I. LISTING OF PROPOSED SUBSTITUTE CLAIMS**

Claims 1, 8 and 20 are to be replaced by substitute claims 22, 23 and 24 respectively, which incorporate elements of claim 11 for which the Board denied review in these proceedings.<sup>2</sup>

**A. Claim Listing**<sup>3</sup>

22. (Proposed substitute for original claim 1) A self-propelled cleaning apparatus for cleaning a submerged surface of a pool or tank, comprising:

a housing having a front portion as defined by the direction of movement of the apparatus when propelled by a water jet, an opposing rear portion and adjoining side portions defining the periphery of the apparatus, and a baseplate with at least one water inlet;

rotationally-mounted supports axially mounted transverse to a longitudinal axis of said apparatus and coupled proximate the front and rear portions of the housing to ~~enable~~ control the directional movement of said apparatus over the submerged surface;

---

<sup>2</sup> Patent Owner is not expressly or impliedly abandoning original claim 1 as the base claim for dependent and intervening claims 7 and 10; claims 7, 10 and 11; and claims 7, 10 and 12. Nor, for the same reason, is claim 1 being abandoned in combination with claims 13 and 15, claim 17, and claims 17 and 18.

<sup>3</sup> Underlined text indicates newly added text. Text with a strikethrough or double brackets indicates text deleted from the claim.

a water pump mounted in the interior of said housing, said water pump being configured to draw water and debris from the pool or tank through the at least one water inlet for filtering; and

a stationary directional discharge conduit in fluid communication with the water pump and having at least one discharge opening through which a pressurized stream of water forming the water jet is directionally discharged at a predetermined angle that is acute with respect the surface over which the apparatus is moving,

wherein said predetermined angle is inclined upwardly with respect to the surface beneath the apparatus to produce a resultant force vector that is directed to a position that is proximate to and rearwardly displaced from a line passing through the transverse axial mountings of the front rotationally-mounted supports.

23. (Proposed substitute for original claim 8) The apparatus of claim [[7]] 22, wherein the rotationally-mounted supports comprise first and second pairs of axially mounted wheels respectively positioned proximate to the front and rear portions of the housing, wherein a portion of the discharge conduit terminating in the at least one discharge opening is angled upward with respect to an adjacent portion of the discharge conduit to produce a resultant force vector in the water jet discharged from said at least one discharge opening that is directed to pass ~~through~~ proximately to and rearwardly of the plane of the axis of rotation of the pair of wheels at the front portion of the apparatus.

24. (Proposed substitute for original claim 20) A self-propelled cleaning apparatus for cleaning a submerged surface of a pool or tank, said apparatus having a longitudinal axis and being propelled by the discharge of a water jet, the apparatus comprising: a housing including a baseplate with at least one water inlet, a front portion, a rear portion and opposing side portions defining the periphery of the apparatus, said front portion being defined with respect to the forward directional movement of the apparatus when propelled by the water jet; ~~rotationally-mounted supports~~ at least a front pair of wheels, each wheel axially mounted transverse to the longitudinal axis and coupled to the housing to ~~enable~~ control the directional movement of said apparatus over the submerged surface; a water pump mounted in the interior of said housing, said water pump configured to draw water and debris from the pool or tank through the at least one water inlet for filtering, and a pump discharge outlet for emitting a pressurized stream of filtered water; a stationary directional discharge conduit in fluid communication with the pump discharge outlet, the discharge conduit having at least one discharge opening through which the filtered water jet is directionally discharged from the apparatus at a predetermined angle that is less than normal with respect to the surface beneath the apparatus, wherein said predetermined angle is inclined upwardly with respect to the surface beneath the apparatus to produce a resultant force vector that is directed

to a position that is proximate to and rearwardly displaced from a line passing through the transverse axial mountings of the front pair of wheels.

## **II. SUPPORT FOR PROPOSED SUBSTITUTE CLAIMS<sup>4</sup>**

### **A. Proposed Substitute Independent Claims 22 and 24**

The amended language relates to the directional positioning of the wheels; and the directional discharge which establishes a defined force vector.

Support for rotationally-mounted supports (substitute claim 22) or at least a front pair of wheels (substitute claim 24), and the inclusion of the orientation as transverse to the longitudinal axis to control the directional movement are supported by the specification, *e.g.*, a pair of wheels/rotationally-mounted supports located at one/both ends of apparatus and mounted transverse to the longitudinal axis. '183 Patent, col. 6, lns. 7-14; col. 17, lns. 50-56; col. 18, lns. 6-9; col. 20, lns. 1-6 and 24-26; col. 21, lns. 36-39; col. 25, lns. 4-6, controlled directional movement of the cleaner at col. 5, lns. 4-9, Figs. 1, 1A, 9, 10 and 31-44.

Support for “stationary” directional discharge in substitute claim 24 was recited in original independent claim 1. '183 Patent, Fig. 9; abstract, col. 4, lns. 54-56; col. 24, lns. 20-21.

---

<sup>4</sup>No substantive changes have been made to the disclosure of parent application 09/237,301 (now U.S. Patent 6,412,133). The matter cited to in the '183 Patent is found in the '133 Patent specification and drawings with respect to the proposed substitute claims.

The inclusion of the predetermined angle of the discharged water jet as being inclined, *i.e.*, angled upwardly, with respect to the surface beneath the cleaning apparatus to produce a resultant force vector “Vr” that is directed proximately to and rearwardly displaced from a line passing through the transverse axial mountings of the front pair of wheels, incorporates original dependent claim 11. ‘183 Patent, col. 10, lns. 47-51 (angled discharge of water); col. 10, line 60 to col. 11, line 3; col. 25, lns. 7-13 (resultant force vector proximate and rearward of front wheel axis of rotation); Figs. 8 and 9.

A line defined as extending transversely between the transverse axial mountings of the front pair of wheels is present either for wheels that have a common axle 32 which extends transversely across the longitudinal axis of the cleaning apparatus (‘183 Patent, Figs. 9, 10) or are individually mounted to an independent axle that does not extend completely across the cleaning apparatus. *Id.*, Figs. 33-36, 39-40. The resultant force vector in the water jet is directed to a position that is proximate to and rearwardly displaced from the line passing through the transverse axial mountings of the front pair of wheels. *Id.*, col. 10, lns. 47-51; col. 10, line 60 - col. 11, line 3; col. 25, lns. 7-13; and Figs. 8 and 9).

#### **B. Proposed Substitute Dependent Claim 23 (Original Claim 8)**

Substitute claim 23 further defines the trajectory of the resultant force vector as being “directed to pass *proximately to and rearwardly of* the plane of the axis of

rotation of the pair of wheels at the front portion of the apparatus.” This conforms the claim language to the language proposed in substitute claim 22.

### **III. PATENTABILITY OF PROPOSED SUBSTITUTE CLAIMS**

The Board’s granted the Petition finding that: (1) Myers’ ‘787 Patent (“Myers”, Exh. 1001) anticipated claims 1-4, 13, 14, 16 and 19-21; (2) claims 1-5 and 19-21 are obvious in view of Henkin’s ‘899 Patent (“Henkin”, Exh. 1002) and Myers; and (3) claims 1–9 and 19-21 are obvious in view of Pansini’s ‘641 Patent (“Pansini”, Exh. 1003) and Myers.

The cited prior art was deemed to be invalidating by the Board in part because of its imposition of the broadest possible interpretation of the claim language. The Board’s claim interpretation may be fairly summarized as a determination that even a totally random movement falls within the scope of the claim because if the direction of movement is forward that, perforce, becomes the “front portion” and thus, the “direction of movement”. Decision at 12. Without conceding that the interpretation is correct, the substitute claims eliminate any controversy about the front portion and movement of the apparatus.

The prior art disclosed three distinct approaches to pool cleaner design. Corrected Declaration of Giora Erlich (“Corrected Erlich Decl.”) ¶ 22. One approach, known as “suction-side cleaners” used the pool’s filtration system/skimmer and a vacuum head that was positioned on the surface of the pool

and connected to the filter system's pump by a long hose to intake water and debris for filtering. Corrected Erlich Decl. ¶ 22(a); *see, e.g.*, U.S. Patent Nos. 5,293,659 (Exh. 2005) at col. 2, lns 52-68, and 5,720,068 (Exh. 2006). Suction-side cleaners are very inefficient from an energy consumption standpoint because the cleaner moved by vibration pulsed motion that caused the vacuum head to randomly "bounce" along the pool bottom or with assistance of rollers positioned on the bottom of the vacuum head. *Id.*.

The second approach, known as pressure-side cleaners, is embodied in Henkin. Corrected Erlich Decl. ¶ 22(b); *see also*, Exhs. 2007, 2008. Pressure-side cleaners rely upon the pool's pumping and filtration systems or booster pumps as the main source of cleaning. The primary objective of the apparatus is to create turbulence and stir-up debris so that it can be taken into the pool's filter. Movement of the apparatus is random. *Id.* To the extent the water jet created by a pump was employed (whether internal or external) to assist movement, the cleaner is inherently unstable. *Id.* ¶ 24.

Robotic cleaners are based upon a different approach and include on-board electric motors to drive patterned movement and a separate internal pump for cleaning with the pump applying a downward force to the cleaner. *Id.* ¶¶ 22(c), 26. Use of the force of the pump as a functional drive mechanism was once believed to be impractical and non-enabling for many reasons, but typically because when the



apparatus came into contact a with pool wall or step it would become unstable. The cleaner would flip-over. *Id.* ¶¶ 28, 29, 31(d),(e),(f), 32; Exhs. 2010(d), (e), (f).

Robotic pool cleaners that provide a controlled path of movement must maintain contact with the pool surface. *Id.* ¶ 26. Robotic pool cleaners have almost neutral buoyancy when under water. *Id.* ¶¶ 26, 79. The pump imparts the negative buoyancy that maintains surface contact. *Id.* ¶ 79. This enables the apparatus to remain stable when encountering a wall and results in both cleaning and navigational benefits. *Id.* In denying the Petition with respect to claims 10-12 of the '183 Patent, the Board implicitly recognized the patentability of claims having an angular/vector force.

In 1999, although some cleaners may have included a water discharge conduit, they had a negligible propulsive force and/or created random movement and/or would become immobilized in sharp corners or on steps of pools. *Id.* ¶¶ 24, 34-36. The first robotic cleaner using the new jet drive technology was Aqua Products' "Pool Rover" in 2001. *Id.* ¶¶ 37, 39. The Pool Rover quickly, efficiently and systematically cleaned the entire pool. *Id.*<sup>5</sup>

---

<sup>5</sup> Consumers reacted positively to Aqua Products' jet drive cleaners purchasing more than 100,000 units in the first 10 years from introduction. Sales have increased every year since 2002. Within approximately 4 years from the introduction of Pool Rover, annual sales exceeded 10,000 units. Today, sales of jet drive products account for more than 2/3 of Aqua Products' total sales of robotic cleaners. Corrected Erlich Decl. ¶ 40.

The Pool Rover was so successful that in or about 2002, Petitioner wanted to acquire Aqua Products. *Id.* ¶ 41. Discussions ensued. Zodiac representatives reviewed technical specifications for the jet drive devices, toured Aqua Products' facilities, observed products and manufacturing operations, and acknowledged that they had not previously contemplated development of jet drive products. *Id.* ¶¶ 41-43.

The discussions ended without a deal but a new initiative took place in 2008. *Id.* ¶¶ 44, 45. Aqua Products provided two jet drive cleaners to Zodiac for evaluation. *Id.* ¶ 44; Exhs. 2011, 2012. The parties discussed having Aqua Products provide jet drive technology for use in Zodiac's products. *Id.* ¶ 47. After testing, Zodiac expressed interest in a possible "joint venture" with Aqua Products. *Id.* ¶ 45. A meeting took place at Zodiac's California facility. Aqua Products made a presentation to Zodiac's high ranking business and technical personnel. The joint venture was never concluded. *Id.* ¶¶ 46-49.

Zodiac recognized the breakthrough development and filed a patent application relating to jet propulsion technology and in about 2009, introduced its next generation of "Polaris" pool cleaners. *Id.* ¶ 50. The new Polaris cleaner was no longer the random driven (Henkin) design. *Id.* ¶ 51. Instead, Zodiac created a robotic cleaner with an internal water pump producing a resultant force vector that

is directed beneath the cleaning apparatus proximate to and rearward of the axis of rotation of the front wheels. *Id.*

### **A. Substitute Claims are Patentable Over Myers**

Proposed substitute claims 22 and 24 distinguish the rotational direction of the wheels from the angled brushes of Myers by providing that they are “axially mounted transverse to the longitudinal axis ... to control the directional movement of said apparatus over the submerged surface”. It is also of note that the Myers’ configuration not only intends uncontrolled and erratic movement (*see id.* ¶¶ 75-76), it may not even move in the direction opposite that of the jet drive. *Id.* ¶ 59. The path may not follow the “front” but can be lateral to it. *Id.* ¶¶ 59, 60. The ‘183 Patent is directed to a controlled movement cleaning apparatus. ‘183 Patent, col. 5, lns. 4-9. Myers does not suggest the claimed trajectory of the resultant force vector. Corrected Erlich Decl. ¶¶ 67, 76-77. Substitute dependent claim 23 (which depends from independent substitute claim 22) is, therefore, also not anticipated by Myers. *RCA Corp. v. Applied Digital Data Sys., Inc.*, 730 F.2d 1440, 1446 (Fed. Cir. 1984).

### **B. Substitute Claims are Not Obvious in View of Henkin and Myers**

Neither Henkin nor Myers suggest an apparatus with the “resultant force vector that is directed to a position that is **proximate to and rearwardly displaced from a line passing through the transverse axial mountings of the front**

**rotationally-mounted supports”** (claim 22) or the **“front pair of wheels”** (claim 24). Corrected Erlich Decl. ¶ 77.

The ‘183 Patent specification teaches that the resultant force vector enables the apparatus to maintain consistent traction with the pool surface, advance the cleaner in a forward direction and maintain proper orientation when contacting a vertical wall that is normal to the horizontal bottom surface beneath the cleaner. ‘183 Patent, col. 10, ln. 60 – col. 11, ln. 3; col. 10, lns. 47–51; col. 25, lns. 10-13; Corrected Erlich Decl. ¶ 78.

When the apparatus comes into contact with a vertical surface normal to the horizontal bottom surface, the angle and direction, *i.e.*, positioning of the resultant force vector  $V_r$ , ensures that the apparatus does not flip up and disrupt the cleaning pattern. Corrected Erlich Decl. ¶ 78. If the resultant force vector were directed forward of the transverse axial line of the front rotationally-mounted supports, the rear end of the apparatus can be impelled to flip upwards and rotate forward towards the vertical sidewall, thereby displacing and hindering the forward ascent of the apparatus up the sidewall. *Id.* ¶¶ 36, 79.

Neither Henkin nor Myers suggest or otherwise provide a person of ordinary skill in the art with any purpose or reason to direct the resultant force vector proximate to and rearwardly displaced from a line passing through the transverse axial mountings of the front rotationally-mounted supports (e.g., a front pair of

wheels), as recited in proposed substitute claim 22 (or claim 24). *Id.* ¶¶ 63, 79. Henkin and Myers did not recognize nor try to solve the problem. *Id.* ¶ 80. For the same reasons, proposed dependant substitute claim 23 is not obvious.

### C. Substitute Claims are not Obvious in View of Pansini and Myers

Neither Pansini nor Myers suggest the resultant force vector that is directed to a position that is **proximate to and rearwardly displaced from a line passing through the transverse axial mountings of “the front rotationally-mounted supports”** (claim 22) or the **“front pair of wheels”** (claim 24). *Id.* ¶ 81.

It is self-evident that Pansini never contemplated this force vector. The angle of the jet nozzle tubes 20 and 22 as shown in FIG. 3 of Pansini produces a resultant force vector that is directed forward of a line passing through the transverse axial mountings of the front pair of wheels. Similarly, any resultant force vector from Myers would be directed towards the upright/normally mounted brushes. *Id.* ¶ 82.

The ‘183 Patent specifies that, “the angle “ $\alpha$ ” [of the resultant force vector] is critical to the proper movement of the robot 10 while on and off the vertical or angled side wall of a pool.” ‘183 Patent, col. 10, lns. 60-64.

If the resultant force vector  $V_r$  is directed forward of the transverse axial line and wheels, as in the Pansini device, as the cleaner moves along a horizontal surface and comes into contact with a substantially normal sidewall, the rear end of

the cleaning apparatus will flip upwards and rotate forward towards the vertical sidewall, thereby displacing and hindering the forward ascent of the cleaning device up the sidewall. Corrected Erlich Decl. ¶¶ 31, 68.

Petitioner's position that Pansini would be modified to include the internal pump of Myers is contrary to the teachings of Pansini. *Id.* ¶ 69. The file history of Pansini discloses how a device driven by the pool's external pump would be highly susceptible to being tipped over by the drag force of the hose which provided the water source to propel the cleaning device. *Id.* ¶ 70. Pansini suggested using the water pumped by the pool nozzles to offset the drag forces applied by the water supply hose. *See* Exh. 2013, Paper No. 8, p. 25 (cancelled claim 19)<sup>6</sup>; Corrected Erlich Decl. ¶¶ 70, 71. The nozzles that are "angled somewhat upwardly" were implemented to provide a counteracting force against the opposing drag forces by the water supply hose and suggested that a pool system implementation was preferable over implementing by an internal pump. Exh. 2013 at 25; Corrected Erlich Decl. ¶¶ 69-72.

Both Pansini and Myers use an external pump with a water supply hose to operate the cleaner despite resultant deficiencies. Corrected Erlich Decl. ¶¶ 60, 61, 70. Indeed, the use of internal pumps was, in 1999 considered highly undesirable

---

<sup>6</sup> Original Pansini claim 19 was canceled by amendment dated August 12, 1977.

even given the very significant increase in cost of operation of a pool pumping system versus an internal pump. *Id.* ¶ 69.

Even assuming that such a substitution might occur to a person of ordinary skill, the combination fails to suggest that “the predetermined angle [of the discharged filtered water] is inclined upwardly with respect to the surface beneath the apparatus to produce a resultant force vector that is directed to a position that is proximate to and rearwardly displaced from a line passing through the transverse axial mountings of the front rotationally-mounted supports.” *Id.* ¶¶ 72, 81, 82. Substitute claim 23 depends from proposed substitute independent claim 22 and is patentable over Pansini and Myers for the same reasons.

#### **IV. CONCLUSION**

Proposed substitute claims 22 - 24 are patentable and supported by the original disclosure of the ‘183 Patent, do not broaden the claims, obviate all grounds of invalidity set forth in the Decision and are consistent with the Board’s ruling that certain claims of the ‘183 Patent should not be the subject of these proceedings.

For all of the foregoing reasons, Patent Owner respectfully requests that the Board grant this Motion to Amend Claims.

Dated: March 3, 2014

/s/Jeffrey A. Schwab  
ABELMAN, FRAYNE & SCHWAB  
Jeffrey A. Schwab (Reg. No. 24,490)

jaschwab@lawabel.com  
Anthony A. Coppola (Reg. No. 41,493)  
aacoppola@lawabel.com  
666 Third Avenue  
New York, New York 10017  
Telephone: (212) 949-9022  
Facsimile: (212) 949-9149  
Email: [jaschwab@lawabel.com](mailto:jaschwab@lawabel.com)

Counsel for Patent Owner,  
Aqua Products, Inc.



**CERTIFICATE OF SERVICE**

The undersigned certifies that on the 3<sup>rd</sup> day of March 2014, a complete and entire copy of the foregoing Patent Owner's Replacement Corrected Motion to Amend Claims and the Corrected Declaration of Giora Erlich were served by electronic mail and Federal Express, postage prepaid, upon legal counsel for the Petitioner as follows:

Christopher D. Bright  
McDermott Will & Emery LLP  
4 Park Plaza, Suite 1700  
Irvine, California 92614

/s/Jeffrey A. Schwab/

**IN THE UNITED STATES PATENT AND TRADEMARK OFFICE**

In the *Inter Partes* Review of:

U.S. Patent No. 8,273,183

Filed: July 12, 2011

Issued: September 25, 2012

Inventors: Giora Erlich et al.

Assignee: Aqua Products, Inc.

For: AUTOMATED SWIMMING POOL CLEANER  
HAVING AN ANGLED JET DRIVE  
PROPULSION SYSTEM

Attorney Docket No.: 084586-0208

Trial Number: IPR2013-00159

Panel: Administrative Patent Judges  
Brian McNamara, Rama Elluru and  
James Arpin

**OPPOSITION TO PATENT OWNER'S REPLACEMENT CORRECTED MOTION TO  
AMEND CLAIMS**

**2. Patent Owner Has Not Shown a Patentable Distinction of Claims 22-24 Over Henkin and Myers**

Patent owner contends that neither Henkin nor Myers provides a reason to direct the resultant force vector as claimed and that “Henkin and Myers did not recognize nor try to solve the problem.” Patent Owner Motion at 12-13. Patent Owner contends that the ’183 patent addresses this problem with the claimed force vector to “maintain consistent traction with the pool surface, advance the cleaner in a forward direction and maintain proper orientation when contacting a vertical wall.” Patent Owner Motion at 12. Elsewhere, the Patent Owner has admitted that Henkin discloses a resultant force vector having this very same purpose: the “angle of the nozzle 90 is selected to yield both a downward thrust component (i.e. normal to the vessel surface) for providing traction and a forward component which aids in propelling the car and facilitates the car climbing vertical surfaces and working itself out of corners.” Patent Owner Response to Petition, paper 28 at 8; Henkin at 5:19-24. Henkin thus discloses the same purpose for the resultant force vector: a vertical component to keep the cleaner from lifting off the surface being cleaned and a horizontal component to propel the cleaner in a forward direction. Kazerooni Decl. ¶ 15-16.

**3. Patent Owner Has Not Shown a Patentable Distinction of Claims 22-24 Over Pansini and Myers**

Patent Owner argues that a *cancelled* claim that describes a relationship between the jet drive force and the drag force of a hose somehow indicate that Pansini can only be used with an external pump, and that it teaches away from using an internal pump. Patent Owner Motion at 14-15. However, the issued claims of Pansini (e.g. claim 1) do not describe such a relationship, yet still claim the jet drive force. Accordingly, there is nothing in Pansini that would teach away from using an internal pump. Kazerooni Decl. ¶ 21.

**IN THE UNITED STATES PATENT AND TRADEMARK OFFICE**

In the *Inter Partes* Review of:  
U.S. Patent No. 8,273,183

Filed: July 12, 2011

Issued: September 25, 2012

Inventors: Giora Erlich et al.

Assignee: Aqua Products, Inc.

For: AUTOMATED SWIMMING POOL  
CLEANER HAVING AN ANGLED  
JET DRIVE PROPULSION SYSTEM

Attorney Docket No.: 222,604

Case No. IPR2013-00159

Panel: Administrative Patent  
Judges Brian McNamara, Rama  
Elluru and James Arpin

**PATENT OWNER'S REPLY IN  
SUPPORT OF MOTION TO  
AMEND CLAIMS**

Dated: April 8, 2014

Filed By:  
Jeffrey A. Schwab (Lead Counsel)  
Reg. No. 24,490  
Abelman, Frayne & Schwab  
666 Third Avenue  
New York, New York 10017  
Telephone: (212) 949-9022  
Facsimile: (212) 949-9149  
Email: jaschwab@lawabel.com

**1. Claims 22-24 are Patentable over Myers**

Myers does not have rotationally-mounted supports (claim 22) or wheels (claim 24) which are “axially mounted transverse to a longitudinal axis of said apparatus.” The two shafts, 16 and 18, of Myers are not parallel. They extend “downwardly and outwardly from each other” and do not traverse the longitudinal axis of the apparatus. Exhibit 1001, col. 2, lines 1-5. Perforce, Myers cannot describe or suggest that the claimed trajectory of the resultant force vector must be “directed to a position that is proximate to and rearwardly displaced from a line passing through the transverse axial mountings of the front rotationally-mounted supports.” Exh. 2016, ¶¶ 67, 75-77.

**2. Claims 22-24 are Patentable over Henkin and Myers**

The same positional limitation that distinguishes Myers also distinguishes Henkin. Exh. 2016, ¶¶ 67, 75-77. Had Petitioner chosen to illustrate FIG. 3 of

---

deal with jet propulsion, pool/tank cleaners or the peculiar and particular dynamics of devices submerged in water. His testimony is devoid of any indication that he has ever analyzed pool cleaners – either in or out of water. To qualify as a POSITA (or one who can speak from the perspective of a POSITA), knowledge of swimming pools/cleaners is required. *See* Exhibit 2021, pp. 21, ln 12 – 22, ln 7.

Henkin, it would be self-evident that Henkin is a three-wheeled outrigger device (Exh. 1002, FIGS. 3 and 4) and that the line passing through the transverse axial mountings extends rearwardly between the leading single wheel axle 59 and the intermediate wheel axle 61 and does not extend perpendicular from a longitudinal axis. *Id.*, FIG. 3; Exh. 2016, ¶¶ 77-80. Because of its wheel orientation, a force on the lead wheel will **not** necessarily provide a controlled force forward. Exh. 2021, pp. 138, ln 21 – 141, ln 25. Petitioner’s added illustrated line drawn proximate to and rearward of the leftmost wheel in Henkin FIG. 4 is visually misleading. Exh. 1010, ¶¶ 14, 15. The resultant force vector appears to extend perpendicular to the longitudinal axis, but it does not. It is angled rearwardly (*Id.* at ¶ 14) and has no preferred orientation. There are an infinite number of trajectories that can be set manually by an end user. Exh. 2016, ¶ 64. This is the antithesis of that which is claimed in the ‘183 patent. *See* Exh. 2021, pp. 136, ln 3 – 138, ln 20. The mere *capability* of a claimed limitation, *i.e.*, “predetermined angle” and trajectory of the resultant force vector, is not the proper inquiry. The issue is whether it would have been obvious to modify the prior art apparatus to arrive at the claimed invention. *In re Giannelli*, \_\_\_ F.3d \_\_\_, No. 2013-1167 at \*8 (Fed. Cir. Jan. 13, 2014). It is un rebutted that a POSITA would not have been so motivated. Petitioner provides no admissible contrary position.

**IN THE UNITED STATES PATENT AND TRADEMARK OFFICE**

In the *Inter Partes* Review of:  
U.S. Patent No. 8,273,183

Filed: July 12, 2011

Issued: September 25, 2012

Inventors: Giora Erlich et al.

Assignee: Aqua Products, Inc.

For: AUTOMATED SWIMMING POOL  
CLEANER HAVING AN ANGLED  
JET DRIVE PROPULSION SYSTEM

Attorney Docket No.: 222,604

Case No. IPR2013-00159

Panel: Administrative Patent  
Judges Brian McNamara, Rama  
Elluru and James Arpin

**PATENT OWNER'S  
CORRECTED REPLY IN  
SUPPORT OF MOTION TO  
AMEND CLAIMS**

Dated: April 15, 2014

Filed By:  
Jeffrey A. Schwab (Lead Counsel)  
Reg. No. 24,490  
Abelman, Frayne & Schwab  
666 Third Avenue  
New York, New York 10017  
Telephone: (212) 949-9022  
Facsimile: (212) 949-9149  
Email: jaschwab@lawabel.com

Aqua Products, Inc. (“Patent Owner”) submits this corrected reply memorandum in support of its Motion to Amend Claims (Paper 42).

The proposed amendments are fully supported, narrow the claims and overcome the prior art principally by limiting them to “a resultant force vector that is directed to a position that is proximate to and rearwardly displaced from a line passing through the transverse axial mountings of the front rotationally-mounted supports”; and “control[ing] the directional movement of said cleaning apparatus.”

**A. Claim 11 and Claims 22 and 24**

Substitute claims 22 and 24 do not recite all the claim 11 verbiage, but defines the same relationship. They require that a “predetermined angle is inclined upwardly with respect to the surface beneath the apparatus to produce a force vector”. Claim 11 recites the relationship *with respect to the discharge conduit* ....” In either case, the resultant force vector is the same. It will always be directed to “a position that is proximate to and rearwardly displaced from a line passing through the transverse axial mountings of the front rotationally-mounted supports.” The resultant force vector is discharged at a predetermined angle that is inclined upwardly with respect to the *discharge conduit* (claim 11) or *the surface beneath the apparatus* (claim 22). Congruency with claim 11 notwithstanding, the proposed amendments narrow the claims and include structural limitations not



present in the issued claims, including specific orientation of the force vector (Exh. 2016, ¶¶ 14(b) and 30) and the wheel orientation that distinguishes over the unstable operation of prior art devices. Exh. 2016, ¶31; Exhs. 2010A-2010F.

**B. “Control” is a Narrowing Limitation**

“Control” as a replacement for “enable” narrows the claims. Either in isolation or in context “control,” read in context of the directional movement of rotational supports that are “axially mounted transverse to the longitudinal axis of the apparatus,” is narrower than “enable” and a feature not disclosed in Myers. Exh. 2016, ¶¶ 75, 76. In isolation, the ordinary definition of “enable” is broad. It is “*to make able; provide with means, opportunity, power, or authority (to do something)*” (Exh. 2018 (*Merriam-Webster New World Dictionary*, (2<sup>nd</sup> Ed.1984) at 459) (emphasis added)) or, using Petitioner’s posit, “to make possible, practical or easy.” Paper 45 at 4. “Enable” subsumes both controlled or uncontrolled enabled movement. “Control” restricts that which is “enabled.” It requires that the rotationally mounted supports (wheels) which are “enabled” be limited to a particular enabled movement, *i.e.*, “controlled random motions with respect to the bottom of the pool or tank.” Exh. 1006, col. 5, lns. 4-9; col. 16, lns. 60-66. Myers’ two angularly oriented brushes create uncontrolled erratic movement. *See* Exh. 2021, pp. 105, ln 14 – 106, ln 23.

**C. There is Antecedent Basis for “Transverse Axial Mountings”**

The limitations of “rotationally-mounted supports ... coupled proximate the front and rear portions of the housing” that are “axially mounted transverse” to the longitudinal axis of the apparatus provide antecedent basis for the traverse axial mounting.

**D. The “Longitudinal Axis” is Defined**

“Longitudinal axis” has the meaning described in the patent specification (*See Markman v. Westview Instruments, Inc.*, 52 F.3d 967, 979 (Fed.Cir.1995)), *i.e.*, that which extends along the length of the apparatus in the direction of movement. Exh. 1006, FIGS. 31A-44 and 25; col. 17, lns. 3-7 and 53-56; col. 18, lns 1-4, 16-20, 21-24. This is consistent with the ordinary dictionary meaning of “longitudinal” [*e.g.*, “running or placed lengthwise: opposed to transverse”] (Exh. 2019) and “axis” [*i.e.*, “a real or imaginary straight line around which the parts of a thing, system, etc. are symmetrically or evenly arranged or composed.”] Exh. 2020. Thus, the “longitudinal axis” is a real or imaginary straight line running or placed lengthwise around which the parts of the apparatus are symmetrically arranged. The rotationally-mounted supports/wheels are axially mounted transverse to the longitudinal axis of the apparatus and the “longitudinal axis” runs

the length of the apparatus symmetrically between the traverse axial mountings of the front and rear rotationally-mounted supports.

**E. Proposed Substitute Claim 23 is Not Broader**

Petitioner posits that by removing the “through” limitation and because the term “rearwardly” is not defined, substitute claim 23 is broader than the original claim. This ignores the claim dependency and that the resultant force vector of claims 23 and 22 is the same. Exh.1006, col. 10, lns 47-51; col. 10, ln 64 to col. 11, ln 3; and col. 17, lns 50-53. Dependent claim 23 requires a resultant force vector that “is directed to a position that is proximate to and rearwardly displaced from a line passing through the transverse axial mountings of the front rotationally-mounted supports”. Claim 23 is patentable for the same reasons as claim 22.

**F. Construction of the Amended Claims**

As interpreted by the Board, “front” in the original claims is determined when considering the “forward” direction of movement. Exh. 2016, ¶¶ 55, 57. The proposed amendments require that the “front” is not variable. However, even if the original claims could be read as permitting variability, Myers does not provide “a front portion as defined by the direction of movement of the cleaning apparatus when propelled by a water jet” and “propelling the apparatus in a **forward** direction of movement.” It is un rebutted that Myers will not necessarily

follow the path being urged by the jet drive. Exh. 2016, ¶ 58. The force vector produced by the water jet and the direction of movement (caused by the brushes and other factors) are not correlated. Exh. 1001, col. 2, ln. 47 – col. 3, ln. 12.

### **G. Erlich's Review of the Prior Art**

There is no deficiency. Patent Owner has made a specific technical disclosure of the state of the art prior to the time of invention and the closest known prior art. (Exh. 2016, ¶13) and indicated features not known or considered a viable alternative for use of a jet drive as the principal propulsion force. *Id.*, ¶¶14(d), 39, 79-81, 83. The term “jet drive” is consistently used as a shorthand for an apparatus which provides the resultant forward propelling force vector having forward and downward components and having the limitations of the substitute claims. *See Id.*, ¶¶ 14(b), 16, 20(b). In a meaningful sense, Patent Owner's position is unrebutted. The declaration of Dr. Kazerooni (Exhibit 1010) does not define a “person of ordinary skill in the art” (“POSITA”) nor adopt Patent Owner's definition. Exh. 2016, ¶ 17.<sup>1</sup>

---

<sup>1</sup> Patent Owner objects to the designation of Dr. Kazerooni as an expert. His testimony should be stricken or given no weight. He has no averred experience in the design, repair or use of robotic swimming pool cleaners. None of his patents

**1. Claims 22-24 are Patentable over Myers**

Myers does not have rotationally-mounted supports (claim 22) or wheels (claim 24) which are “axially mounted transverse to a longitudinal axis of said apparatus.” The two shafts, 16 and 18, of Myers are not parallel. They extend “downwardly and outwardly from each other” and do not traverse the longitudinal axis of the apparatus. Exhibit 1001, col. 2, lines 1-5. Perforce, Myers cannot describe or suggest that the claimed trajectory of the resultant force vector must be “directed to a position that is proximate to and rearwardly displaced from a line passing through the transverse axial mountings of the front rotationally-mounted supports.” Exh. 2016, ¶¶ 67, 75-77.

**2. Claims 22-24 are Patentable over Henkin and Myers**

The same positional limitation that distinguishes Myers also distinguishes Henkin. Exh. 2016, ¶¶ 67, 75-77. Had Petitioner chosen to illustrate FIG. 3 of

---

deal with jet propulsion, pool/tank cleaners or the peculiar and particular dynamics of devices submerged in water. His testimony is devoid of any indication that he has ever analyzed pool cleaners – either in or out of water. To qualify as a POSITA (or one who can speak from the perspective of a POSITA), knowledge of swimming pools/cleaners is required. *See* Exhibit 2021, pp. 20, ln 10 – 22, ln 7.

Henkin, it would be self-evident that Henkin is a three-wheeled outrigger device (Exh. 1002, FIGS. 3 and 4) and that the line passing through the transverse axial mountings extends rearwardly between the leading single wheel axle 59 and the intermediate wheel axle 61 and does not extend perpendicular from a longitudinal axis. *Id.*, FIG. 3; Exh. 2016, ¶¶ 77-80. Because of its wheel orientation, a force on the lead wheel will **not** necessarily provide a controlled force forward. Exh. 2021, pp. 137, ln 21 – 141, ln 8. Petitioner’s added illustrated line drawn proximate to and rearward of the leftmost wheel in Henkin FIG. 4 is visually misleading. Exh. 1010, ¶¶ 14, 15. The resultant force vector appears to extend perpendicular to the longitudinal axis, but it does not. It is angled rearwardly (*Id.* at ¶ 14) and has no preferred orientation. There are an infinite number of trajectories that can be set manually by an end user. Exh. 2016, ¶ 64. This is the antithesis of that which is claimed in the ‘183 patent. *See* Exh. 2021, pp. 135, ln 3 – 137, ln 20. The mere *capability* of a claimed limitation, *i.e.*, “predetermined angle” and trajectory of the resultant force vector, is not the proper inquiry. The issue is whether it would have been obvious to modify the prior art apparatus to arrive at the claimed invention. *In re Giannelli*, \_\_\_ F.3d \_\_\_, No. 2013-1167 at \*8 (Fed. Cir. Jan. 13, 2014). It is un rebutted that a POSITA would not have been so motivated. Petitioner provides no admissible contrary position.

**3. Claims 22-24 are Patentable over Pansini and Myers**

Pansini also fails to disclose that the resultant force “is directed to a position that is proximate to and rearwardly displaced from a line passing through the transverse axial mountings of the front rotationally-mounted supports.” Although none is shown, if one were to superimpose such a vector on the jet nozzle tubes 20 and 22 depicted in FIG. 3 of Pansini (Exh. 1003), it would be positioned **forward** of a line passing through the transverse axial mountings of the front pair of wheels. To the extent a force vector could be derived from Myers’ illustrations, it would be directed generally towards the upright brushes. Exh. 2016, ¶ 82.

**Conclusion**

For all of the foregoing reasons, Patent Owner respectfully requests that its Motion to Amend Claims be granted in all respects.

Dated: April 15, 2014

/s/Jeffrey A. Schwab  
ABELMAN, FRAYNE & SCHWAB  
Jeffrey A. Schwab (Reg. No. 24,490)  
[jaschwab@lawabel.com](mailto:jaschwab@lawabel.com)  
Anthony A. Coppola (Reg. No. 41,493)  
[aacoppola@lawabel.com](mailto:aacoppola@lawabel.com)  
666 Third Avenue  
New York, New York 10017  
Telephone: (212) 949-9022  
Facsimile: (212) 949-9149  
Counsel for Patent Owner,  
Aqua Products, Inc.

**IN THE UNITED STATES PATENT AND TRADEMARK OFFICE**

In the *Inter Partes* Review of:  
U.S. Patent No. 8,273,183

Filed: July 12, 2011

Issued: September 25, 2012

Inventors: Giora Erlich et al.

Assignee: Aqua Products, Inc.

For: AUTOMATED SWIMMING POOL  
CLEANER HAVING AN ANGLED  
JET DRIVE PROPULSION SYSTEM

Attorney Docket No.: 222,604

Case No. IPR2013-00159

Panel: Administrative Patent  
Judges Brian McNamara, Rama  
Elluru and James Arpin

**PATENT OWNER'S  
SUBMISSION OF  
DEMONSTRATIVE EXHIBITS  
37 C.F.R. § 42.70**

Dated: May 13, 2014

Filed By:  
Jeffrey A. Schwab (Lead Counsel)  
Reg. No. 24,490  
Abelman, Frayne & Schwab  
666 Third Avenue  
New York, New York 10017  
Telephone: (212) 949-9022  
Facsimile: (212) 949-9190  
Email: jaschwab@lawabel.com



Aqua Products, Inc. (“Patent Owner”) hereby submits the following demonstrative exhibits pursuant to 37 C.F.R § 42.70:

1. Prior Art Myers ‘787 (Fig. 2)
2. Prior Art Myers ‘787 (Fig. 1)
3. Prior Art Pansini ‘641 (Fig. 3)
4. Prior Art Henkin ‘899 (Fig. 4)
5. Prior Art Henkin ‘899 (Fig. 3)
6. Zodiac Indigo (Club Member Technical Guide (Exhibit 2023))
7. Time Line of Key Events

Dated: May 13, 2014

/s/Jeffrey A. Schwab  
ABELMAN, FRAYNE & SCHWAB  
Jeffrey A. Schwab (Reg. No. 24,490)  
[jaschwab@lawabel.com](mailto:jaschwab@lawabel.com)  
Anthony A. Coppola (Reg. No. 41,493)  
[aacoppola@lawabel.com](mailto:aacoppola@lawabel.com)  
666 Third Avenue  
New York, New York 10017  
Telephone: (212) 949-9022  
Facsimile: (212) 949-9190  
Counsel for Patent Owner,  
Aqua Products, Inc.

**CERTIFICATE OF SERVICE**

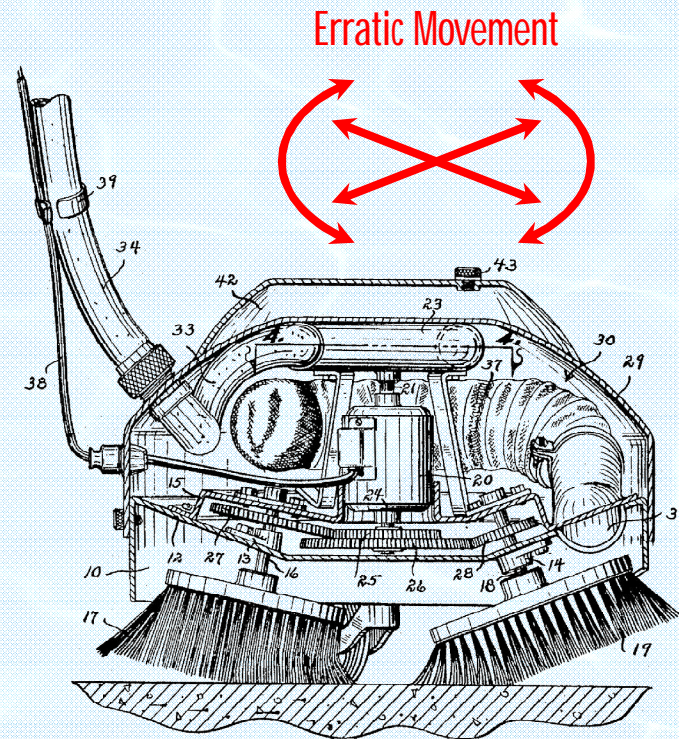
The undersigned certifies that on the 13<sup>th</sup> day of May 2014, a complete and entire copy of the foregoing **PATENT OWNER'S SUBMISSION OF DEMONSTRATIVE EXHIBITS TO 37 C.F.R. § 42.70** was served by electronic mail and Federal Express, postage prepaid, upon legal counsel for the Petitioner as follows:

Christopher D. Bright  
Gregory Yoder  
McDermott Will & Emery LLP  
4 Park Plaza, Suite 1700  
Irvine, California 92614  
[cbright@mwe.com](mailto:cbright@mwe.com)  
[gyoder@mwe.com](mailto:gyoder@mwe.com)

/s/Jeffrey A. Schwab/

# Prior Art Myers '787 (Fig. 2)

The direction of the water jet that is discharged from the stationary discharge conduit and the direction of movement are not correlated



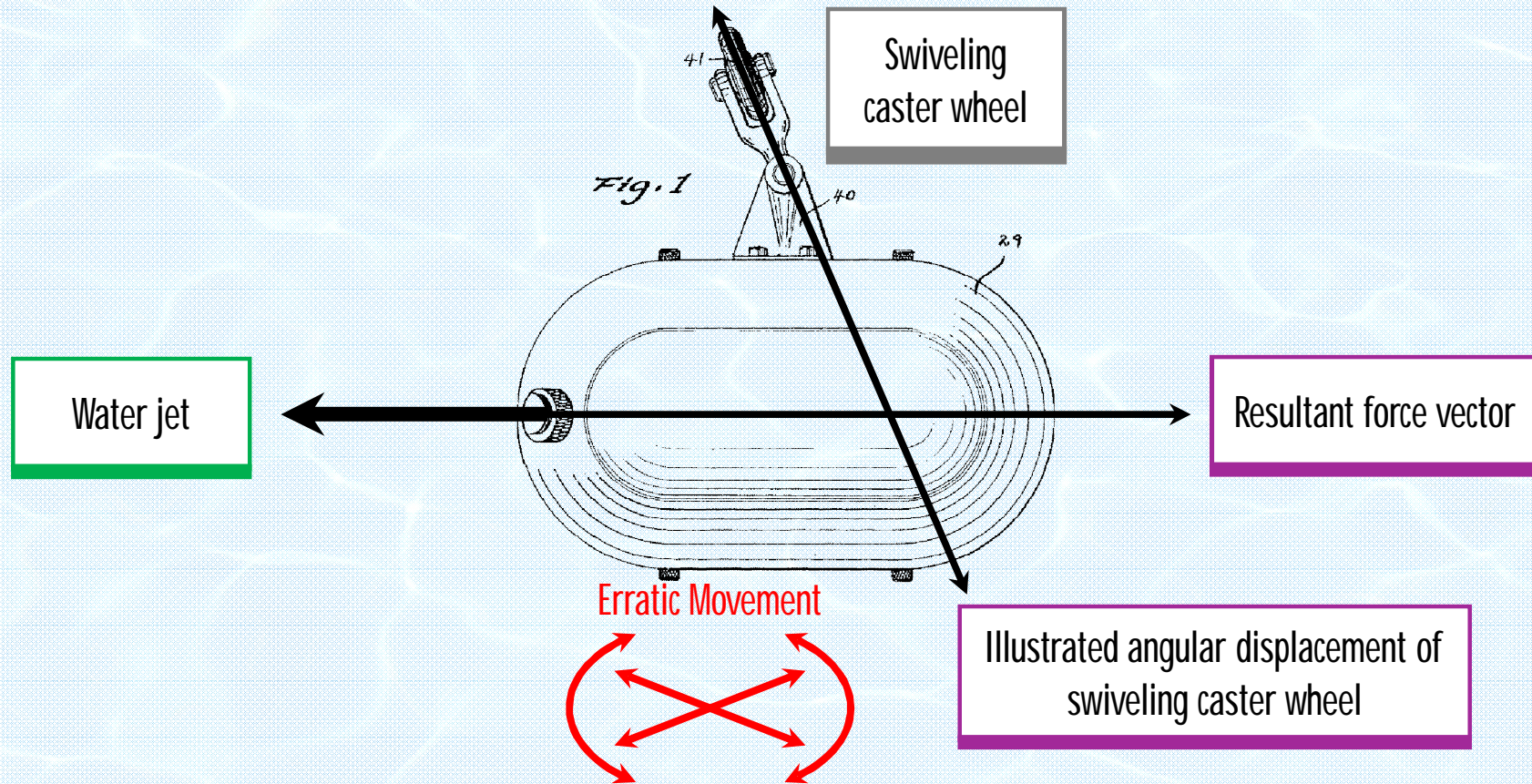
The "front" of Myers is variable with the direction of movement and not correlated to the linear direction of the resultant force vector from the water jet

No "front portion as defined by the direction of movement of the cleaning apparatus when propelled by a water jet"  
'183 Patent, Claim 21, Col. 26, Lns. 29-31

- Myers requires erratic movement, not forward movement (Myers Patent, Col. 2, Lns. 47-59)
- The angular displacement of the swiveling caster wheel from the direction of the horizontal force vector component produced by the discharged water jet may propel the cleaner in directions other than "forward"

Fig. 2

# Prior Art Myers '787 (Fig. 1)\*



- The angular displacement of the swiveling caster wheel from the direction of the horizontal force vector component produced by the discharged water jet may propel the cleaner in directions other than forward and creates "variable" fronts, not "a front portion as defined by the direction of movement" ('183 Patent, Claim 21, Col. 26, Lns. 29-30)
- No "rotationally mounted supports axially mounted transverse to a longitudinal axis of said apparatus and coupled proximate the front and rear portions of the housing to control the directional movement of said apparatus over the submerged surface" ('183 Patent, Proposed Amended Claim 22)

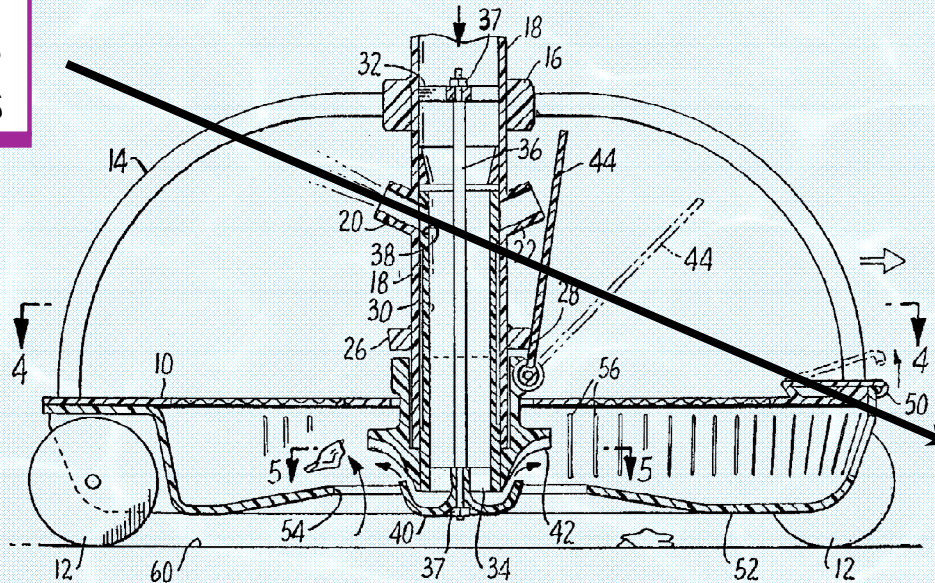
\* External pump hose 34 removed

# Prior Art Pansini '641 (Fig. 3)

External pump from pool filter system  
Pansini Patent, Col. 2, Lns. 61-65

Angle of the jet nozzle is above the axial mountings of the front pair of wheels

Water discharged through nozzle 20 is not filtered through filter tray 52  
Pansini Patent, Col. 3, Lns. 9-27



No "resultant force vector that is directed to a position that is proximate to and rearwardly displaced from a line passing through the transverse axial mountings of the front pair of wheels"  
'183 Patent, Proposed Amended Claim 24

- Pansini prosecution history shows that the purpose of the invention was to utilize an external pump (Exh. 2013 at 25)
- The Pansini cleaner may be unstable and not move in a "forward" direction given the resistance of the external pump hose and the cleaner's tendency to flip over (Exh. 2016, ¶¶ 36 and 68)
- No recognition in Pansini and Myers of a "resultant force vector that is directed to a position that is proximate to and rearwardly displaced from a line passing through the transverse axial mountings of the front pair of wheels" ('183 Patent, Proposed Amended Claim 24)

Fig. 3

# Prior Art Henkin '899 (Fig. 4)

Utilizes water-activated turbines to drive the wheels instead of a water jet and teaches away from using an internal pump  
Henkin Patent, Col. 4, Lns. 8-15

External booster pump  
Henkin Patent, Col. 6, Lns. 47-49

Discharge conduit 90 contributes to the cleaner operating in a highly random manner  
Henkin Patent, Col. 7, Lns. 45-51

Directional discharge conduit does not discharge filtered water

Discharge conduit is designed to be optionally set by end user at an angle without regard to direction of resultant force vector  
Henkin Patent, Col. 7, Lns. 45-51;  
Col. 8, Lns. 1-2

The water jet discharge assists only in random movement  
Henkin Patent, Col. 7, Lns. 45-51

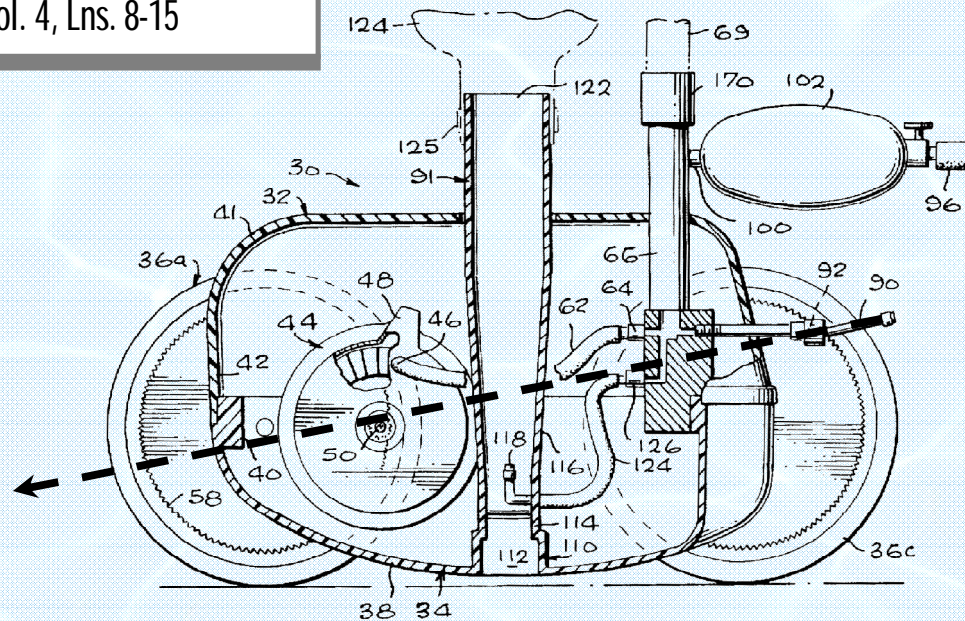
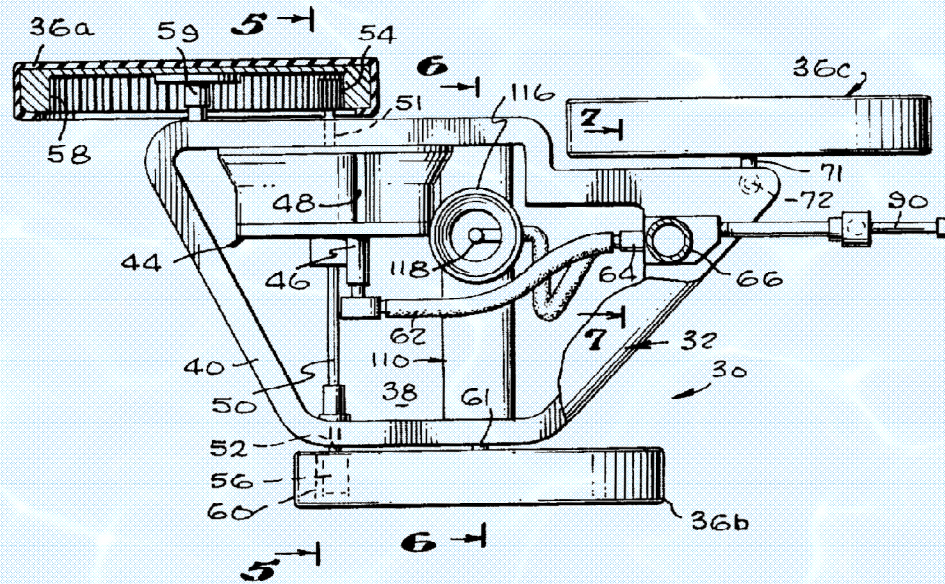


Fig. 4

# Prior Art Henkin '899 (Fig. 3)



- Henkin and Myers move randomly (Henkin Patent, Col. 7, Lns. 45-51; Myers Patent, Col. 2, Lns. 47-59)
- The resultant force vector produced by the water jet does not necessarily propel Henkin or Myers in a forward direction
- Myers does not suggest the angular relationship of Henkin
- Henkin and Myers do not recognize the criticality of the angular relationship
- No "resultant force vector that is directed to a position that is proximate to and rearwardly displaced from a line passing through the transverse axial mountings of the front pair of wheels" ('183 Patent, Proposed Amended Claim 24)

Fig. 3

**IN THE UNITED STATES PATENT AND TRADEMARK OFFICE**

In the *Inter Partes* Review of:

U.S. Patent No. 8,273,183

Filed: July 12, 2011

Issued: September 25, 2012

Inventors: Giora Erlich et al.

Assignee: Aqua Products, Inc.

For: AUTOMATED SWIMMING POOL  
CLEANER HAVING AN ANGLED JET  
DRIVE PROPULSION SYSTEM

Attorney Docket No.: 084586-0208

Trial Number: IPR2013-00159

Panel: Administrative Patent  
Judges Brian McNamara, Rama  
Elluru and James Arpin

**PETITIONER'S SUBMISSION OF DEMONSTRATIVES**

Zodiac Pool Systems, Inc. hereby submits the attached demonstrative exhibits pursuant to 37 C.F.R § 42.70.

Respectfully submitted,

MCDERMOTT WILL AND EMERY

/s/ Christopher D. Bright

Christopher Bright (Lead Counsel)

Reg. No. 46578

Mark Bentley, (Reg. No. 60,460)

Gregory Yoder (Reg. No. 60,460)

4 Park Plaza, Suite 1700

Irvine, CA 92614-2559

Phone: (949) 851-0633

Fax: (949) 851-9348



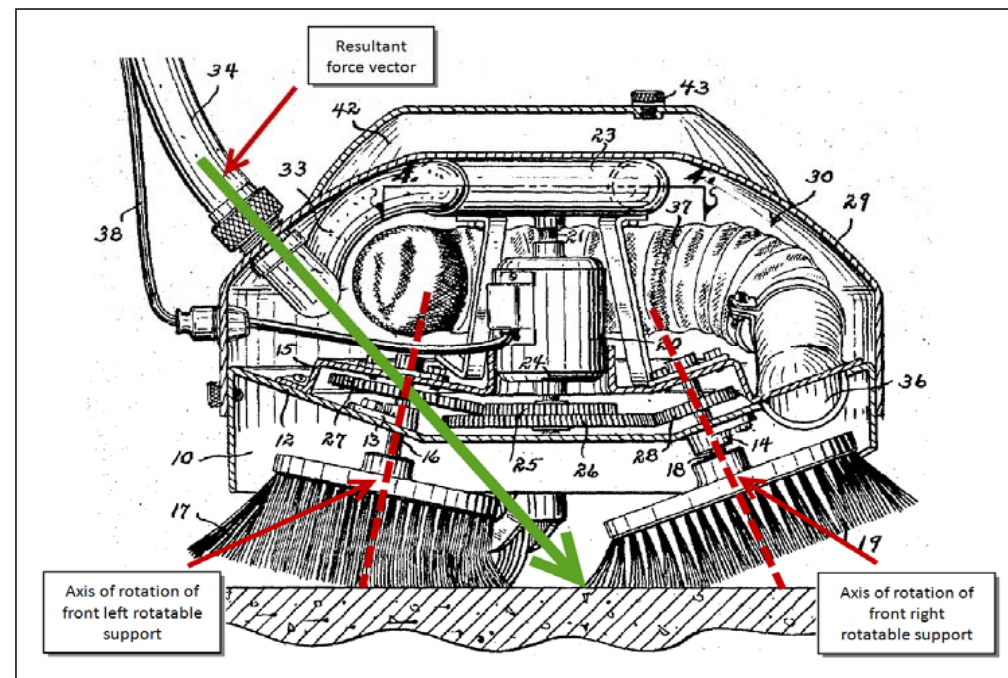
# Claim 21: Myers

McDermott  
Will & Emery

21. A method for cleaning a submerged surface of a pool or tank, comprising the steps of:

...

discharging the filtered water through the directional discharge conduit at an acute angle with respect to the surface over which the apparatus is moving, said discharged filtered water forming a water jet having a resultant force vector acutely angled towards the surface beneath the apparatus; and propelling the apparatus in a forward direction of movement.

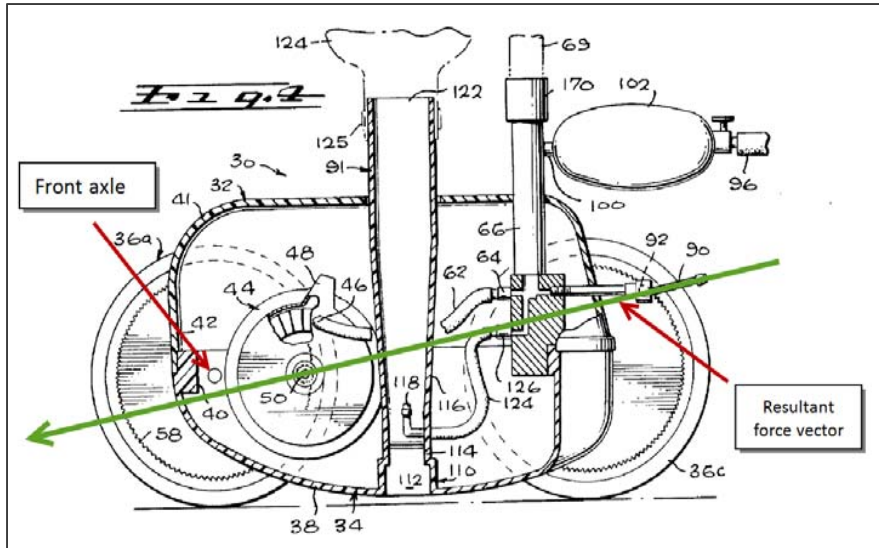


Opp. to Mtn. to Amend at 14.

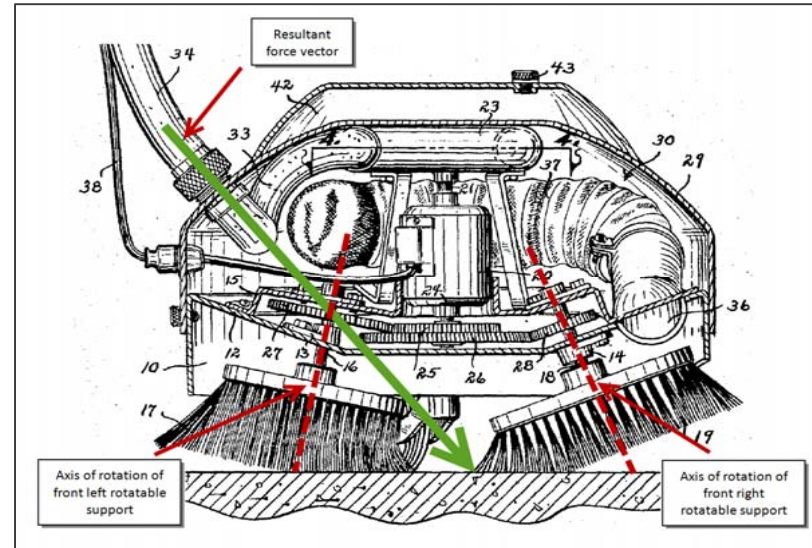
# Proposed Substitute Claims 22-24: Henkin in view of Myers

McDermott  
Will & Emery

wherein said predetermined angle is inclined upwardly with respect to the surface beneath the apparatus to produce a resultant force vector that is directed to a position that is proximate to and rearwardly displaced from a line passing through the transverse axial mountings of the front rotationally-mounted supports.



Petition at 43.



Opp. to Mtn. to Amend at 14.

# **EXHIBIT**

# **1001**

May 30, 1967

R. R. MYERS

3,321,787

SWIMMING POOL CLEANING MEANS

Filed Dec. 17, 1964

2 Sheets-Sheet 1

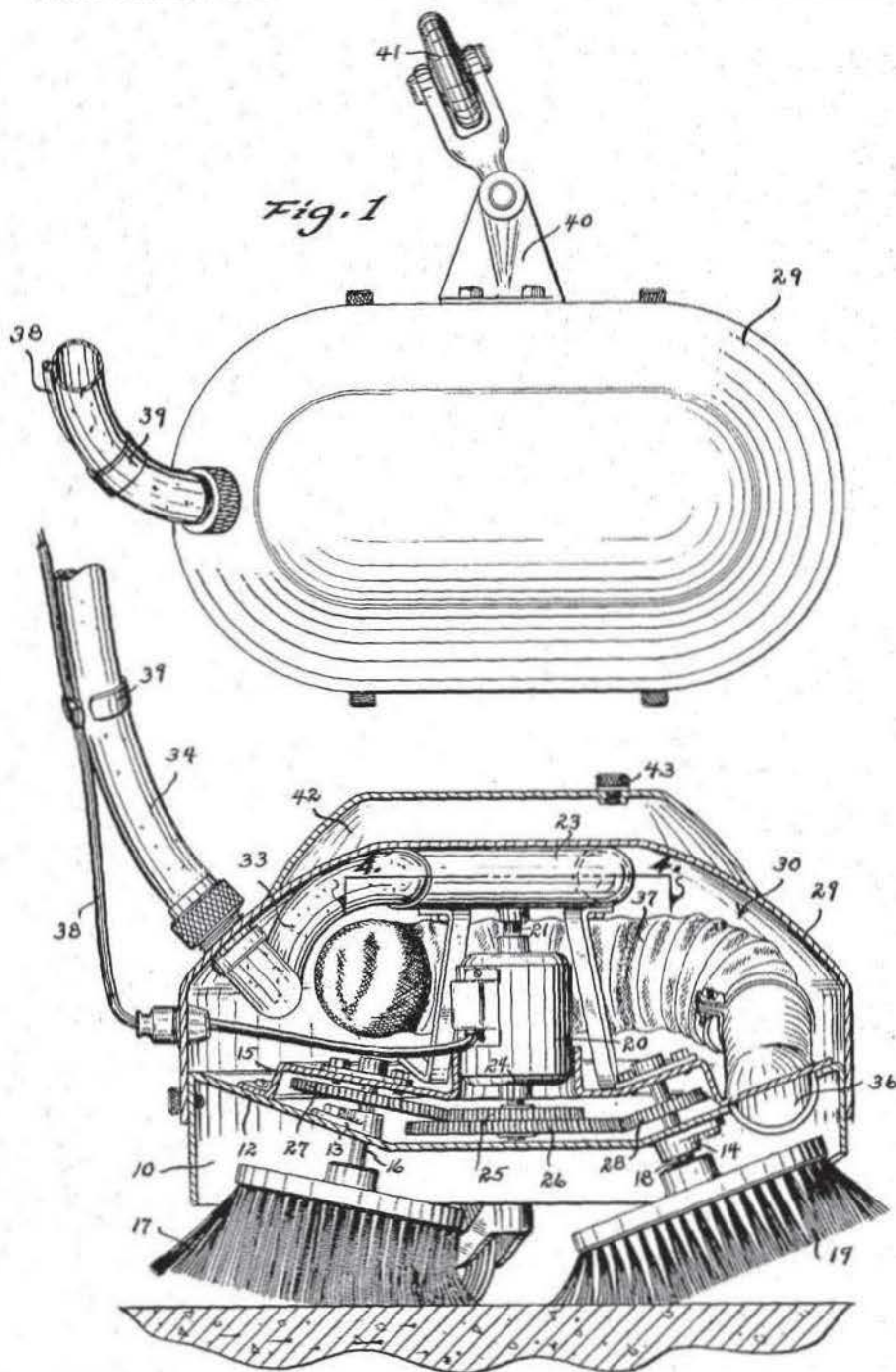


Fig. 2

INVENTOR  
**ROBERT R. MYERS**  
 BY *Dick & Jarley*  
 ATTORNEYS

May 30, 1967

R. R. MYERS

3,321,787

SWIMMING POOL CLEANING MEANS

Filed Dec. 17, 1964

2 Sheets-Sheet 2

Fig. 4

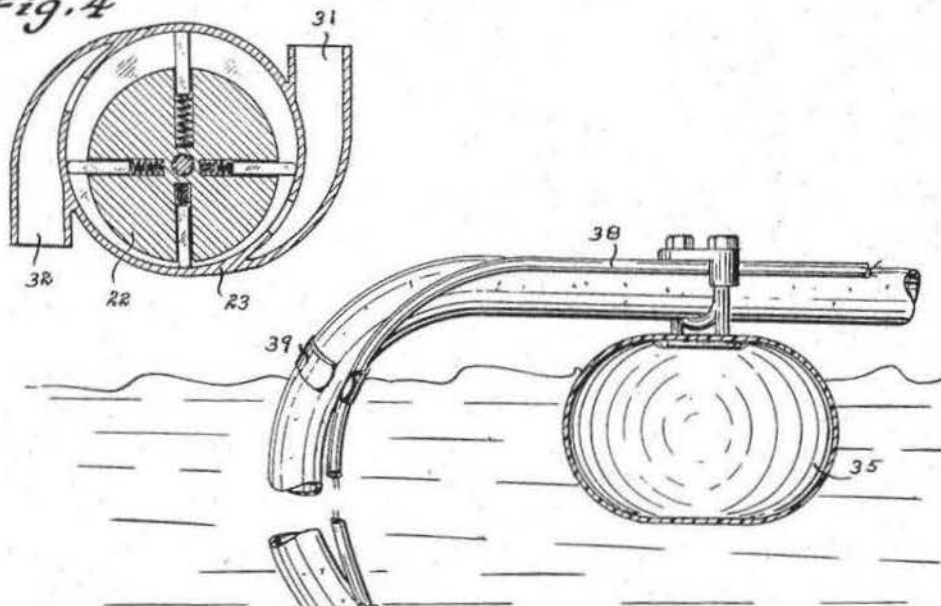
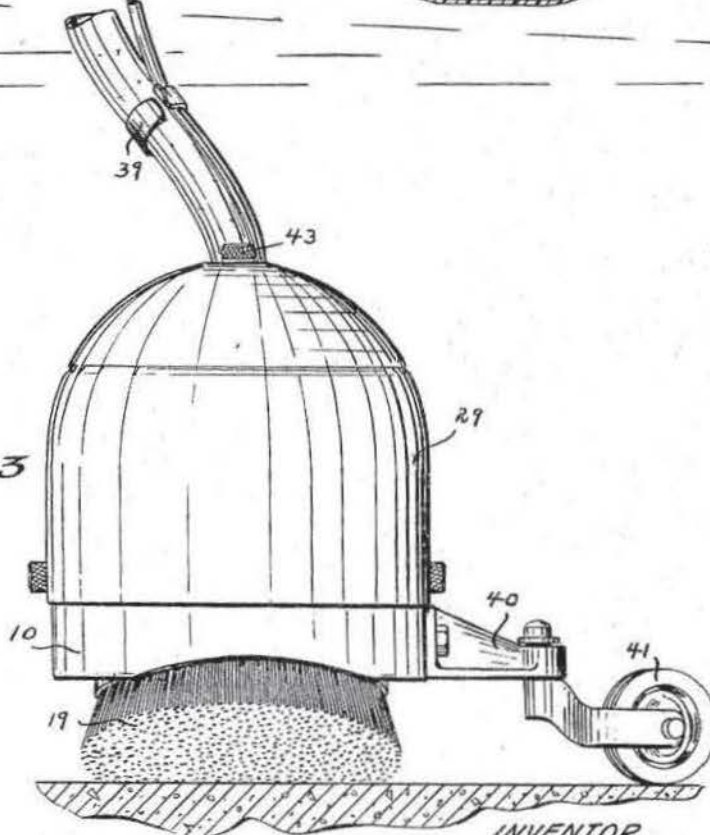


Fig. 3



INVENTOR  
ROBERT R. MYERS  
BY *Dick & Zarley*  
ATTORNEYS

## United States Patent Office

3,321,787

Patented May 30, 1967

1

3,321,787

## SWIMMING POOL CLEANING MEANS

Robert R. Myers, 904 NE. 2nd St.,

Boca Raton, Fla. 33432

Filed Dec. 17, 1964, Ser. No. 419,136

18 Claims. (Cl. 15-1.7)

This invention relates to a swimming pool cleaning device and more particularly to a cleaning means that is erratically self-propelled over the bottom surface of the swimming pool.

It is a major task to successfully clean the bottom area of a swimming pool of objectionable foreign matter. The most common method is to first drain all the water from the pool and then hand scrub and clean the pool. Obviously this is a waste of a great amount of water, time consuming, and much labor.

Therefore, one of the principal objects of my invention is to provide a mechanical janitor means that will submerge to the bottom of the water filled pool and remove undesirable foreign matter.

A further object of this invention is to provide a pool cleaning means that will erratically self-propel itself over the bottom floor of the pool.

A still further object of this invention is to provide a swimming pool cleaning device that requires little attention from the operator.

A still further object of this invention is to provide a mechanical swimming pool cleaner that may be selectively operated either by electric motor-power or by suction.

Still further objects of my invention are to provide a swimming pool cleaning means that is economical in manufacture and durable in use.

These and other objects will be apparent to those skilled in the art.

This invention consists in the construction, arrangements, and combination of the various parts of the device, whereby the objects contemplated are attained as hereinafter more fully set forth, specifically pointed out in the claims, and illustrated in the accompanying drawings, in which:

FIG. 1 is a top plan view of the device;

FIG. 2 is a cross-sectional view of the device;

FIG. 3 is a side view of the device in operation; and

FIG. 4 is a horizontal sectional view of the pump-motor taken on line 4-4 of FIG. 2.

In these drawings I have used the numeral 10 to generally designate the chassis in the form of an inverted cup member having a straight vertical wall as shown in FIG. 2. The top of the inverted cup has its outer area 12 sloping inwardly and downwardly and supports the two diametrically positioned bearings 13 and 14. The numeral 15 designates a cap detachably secured on the top of the inverted cup and having its top conforming in general to the top of the inverted cup. The numeral 16 designates a rotatably mounted shaft extending through the bearing 13 and bearing through the cap 15. On the lower end of the shaft 16 is a surface engaging element such as a brush or like 17. The numeral 18 designates a rotatably mounted shaft journaled through the bearing 14 and bearing through the cap 13. On the lower end of the shaft 18 is a surface engaging element such as a brush or like 19. The numeral 20 designates a vertical water tight sealed electric motor secured to the center of the cap 15. This motor has an upper drive shaft 21 connected to the rotor 22 of an ordinary rotary pump 23 capable of acting either as a pump or as a motor. The lower drive shaft 24 of the electric motor extends downwardly and carries two gear wheels 25 and 26 between the cup 13 and cap 15. The gear wheel 25 is in mesh with a gear wheel 27 on the shaft 16.

The gear wheel 26 is in mesh with the gear wheel 28 on

2

the shaft 18. The two shafts 16 and 18 are not parallel with each other in that they extend downwardly and outwardly from each other. Both shafts are at an angle to the vertical and one of the shafts is at a greater angle to the vertical than the other shaft as shown in FIG. 2. Detachably secured to and over the top of the chassis cup and cap is a hood 29 providing an enclosed compartment 30. In this compartment is the pump-motor 23 having the usual inlet opening 31 and outlet opening 32. The inlet opening 31 communicates with the inside of the compartment 30. A flexible conduit 33 has one end connected to the outlet opening 32 and its other end terminating just outside the hood 29. Operatively detachably secured to the outer end of the conduit 33 is an elongated flexible conduit such as a rubber-like hose 34. This elongated conduit is adapted to extend to a point outside the pool and if desired may be connected to a powered suction means such as a motorized pump (not shown). To prevent this conduit 34 from getting tangled with the scrubbing unit, part of its length may be movably supported at the top water surface of the pool by floats or like 35. The numeral 36 designates a passageway in the bottom of the compartment 30 communicating with the inside of the inverted chassis cup 10. Detachably secured to this passageway 36 is a pocket-type noncollapsible filter 37. This filter is inside the compartment and its porous wall permits water to pass through but not collectible foreign matter. The numeral 38 designates an electric lead wiring to the electric motor and which may be secured to the conduit 34 or float 35 by detachable clamps 39. This lead wiring is adapted to be detachably connected to a source of electrical energy for powering the electric motor when desired.

To stabilize the unit from possible upsetting I have provided a horizontal arm 40 carrying a caster wheel 41. Thus the unit will be supported by the two scrubbing elements 17 and 19 and the caster wheel 41. To further maintain the upright position of the unit I have provided an air compartment 42 on the top of the hood having a detachable cap plug 43. However if it is not desired to have a maximum air cell at the top of the unit, the plug 43 may be removed and the compartment 42 filled or partially filled with water. If it is desired to place more weight on the scrubbing elements, the compartment 42 may be filled with material heavier than water, such as sand or like.

As herebefore indicated the unit is required to propel itself erratically over the bottom surface of the pool. It must, without attention of the user, be able to engage a wall of the pool, change its course of direction, and proceed intermittently to other locations. This erratic movement will eventually cause the scrubbing elements to contact all the bottom surface of the pool. I have used several methods for causing this erratic movement of the unit. Obviously the movement of the unit is caused by the rotating scrubbing elements and the erratic travel can be due to one scrubbing element having more traction on the pool bottom surface than the other scrubbing element. In the drawings I show the two brushes set at an angle downwardly and away from each other. Therefore, occasionally one brush will obtain more traction than the other and turn the unit accordingly. Also one brush is at a different angle to the vertical than the other. The bristles of the brushes extend beyond the chassis cup 10 and therefore will not only scrub the bottom edge of the pool, but some of the pool wall adjacent the pool floor. By one brush contacting this edge portion and wall it will obtain different traction than the other brush. Also to further get this varied action, in the drawings I show one brush with longer bristles than the other. Also with one brush having coarser bristles than the other, Also with one brush having a greater diameter than the other.

3,321,787

3

Also by different size gears, one brush will rotate faster than the other. If desired the two brushes may rotate in opposite directions by one brush shaft being directly connected to the power shaft or by the power shaft being connected to one brush shaft by belt and pulleys or like.

Also if the electric motor is operating as a motor, and the conduit 33 is detached, the water exiting from the unit and into the pool will provide a jet force to move the unit. Also due to the gear wheel sizes and other placed elements more weight will be borne on by one brush than the other brush. This particularly is true if the conduit 33 is attached.

Still another change of traction takes place when the unit gets into deep water, or the float is so adjusted that it is pulled downwardly below the water surface by the greater weight of the unit. Obviously part of the side weight of the unit will be supported by the float. The angle of the brush shafts may be changed as desired by changing the positions of their bearings. If desired the shafts may be placed parallel to each other to meet certain pool conditions or if desired the shafts may be set so that they are at the same angle to the vertical. Still another pool condition may require the clipping of the brush bristles to provide an uneven attack on the pool floor or wall.

The operation of the unit may be accomplished in a variety of ways to meet requirements. If the electric motor is being used as the power means and the pool is contaminated by both sludge, leaves and the like, the filter will be attached to catch the foreign matter and with the elongated conduit removed the cleaned water will be exited back into the pool. With the elongated conduit attached, the water may be exited outside of the pool. If this is desired, and the foreign matter is in the form of sludge, the filter element may be removed entirely. However, with the filter attached, it will collect larger articles, such as leaves and the like that might foul the pump. When the filter becomes full of foreign matter it is removed and emptied. If the foreign matter is of small articles, and if desired, the filter may be placed on the outlet side of the pump. When the pump is used as the motor power to turn the brushes, the electric motor is not turned on, the elongated conduit is attached to a suction source outside the pool and to the pump outlet conduit. When this arrangement is used, the electric motor shaft will be rotated by the pump-motor

From the foregoing it will be appreciated that I have provided a highly efficient pool cleaning means and one that requires little attention from the operator.

Some changes may be made in the construction and arrangement of my swimming pool cleaning means without departing from the real spirit and purpose of my invention, and it is my intention to cover by my claims, any modified forms of structure or use of mechanical equivalents which may be reasonably included within their scope.

I claim:

1. A submarine cleaner including a chassis adapted to be submerged beneath the liquid in a tank for cleaning the bottom surface of the tank, said cleaner comprising, two rotatably mounted brushes operatively connected to said chassis, means for rotating said brushes, said rotatable brushes being in engagement with the bottom surface of the tank for cleaning said bottom surface and driving said cleaner over said bottom surface, said rotatable brushes being the only powered drive means in contact with the bottom surface of said tank, and means for removing foreign matter agitated by said brushes; one of said brushes having an axis at an angle different than that of the angle of axis of said other brush.
2. A submarine cleaner including a chassis adapted to

4

be submerged beneath the liquid in a tank for cleaning the bottom surface of the tank, said cleaner comprising, two rotatably mounted brushes operatively connected to said chassis,

means for rotating said brushes, said rotatable brushes being in engagement with the bottom surface of the tank for cleaning said bottom surface and driving said cleaner over said bottom surface, said rotatable brushes being the only powered drive means in contact with the bottom surface of said tank,

and means for removing foreign matter agitated by said brushes;

one of said brushes having a surface engaging portion of a different character than the character of the surface engaging portion of said other brush.

3. A submarine cleaner including a chassis adapted to be submerged beneath the liquid in a tank for cleaning the bottom surface of the tank, said cleaner comprising, two rotatably mounted brushes operatively connected to said chassis,

means for rotating said brushes, said rotatable brushes being in engagement with the bottom surface of the tank for cleaning said bottom surface and driving said cleaner over said bottom surface, said rotatable brushes being the only powered drive means in contact with the bottom surface of said tank,

and means for removing foreign matter agitated by said brushes;

one of said brushes having a diameter greater than that of the diameter of said other brush.

4. A submarine cleaner including a chassis adapted to be submerged beneath the liquid in a tank for cleaning the bottom surface of the tank, said cleaner comprising, two rotatably mounted brushes operatively connected to said chassis,

means for rotating said brushes, said rotatable brushes being in engagement with the bottom surface of the tank for cleaning said bottom surface and driving said cleaner over said bottom surface, said rotatable brushes being the only powered drive means in contact with the bottom surface of said tank,

and means for removing foreign matter agitated by said brushes;

one of said brushes having means for causing it to rotate faster than said other brush.

5. A submarine cleaner including a chassis adapted to be submerged beneath the liquid in a tank for cleaning the bottom surface of the tank, said cleaner comprising, two rotatably mounted bristle brushes operatively connected to said chassis,

means for rotating said brushes, said rotatable brushes being in engagement with the bottom surface of the tank for cleaning said bottom surface and driving said cleaner over said bottom surface, said rotatable brushes being the only powered drive means in contact with the bottom surface of said tank,

and means for removing foreign matter agitated by said brushes;

one of said brushes having longer bristles than the bristles of said other brush.

6. A submarine cleaner including a chassis adapted to be submerged beneath the liquid in a tank for cleaning the bottom surface of the tank, said cleaner comprising, two rotatably mounted brushes operatively connected to said chassis,

means for rotating said brushes, said rotatable brushes being in engagement with the bottom surface of the tank for cleaning said bottom surface and driving said cleaner over said bottom surface, said rotatable brushes being the only powered

3,321,787

5

drive means in contact with the bottom surface of said tank,  
and means for removing foreign matter agitated by said brushes;  
one of said brushes having coarser bristles than the  
bristles of said other brush. 5

7. A submarine cleaner including a chassis adapted to be submerged beneath the liquid in a tank for cleaning the bottom surface of the tank, said cleaner comprising,  
two rotatably mounted brushes operatively connected to said chassis, 10  
means for rotating said brushes,  
said rotatable brushes being in engagement with the bottom surface of the tank for cleaning said bottom surface and driving said cleaner over said bottom surface, said rotatable brushes being the only powered drive means in contact with the bottom surface of said tank, 15  
and means for removing foreign matter agitated by said brushes;  
one of said brushes having a greater number of bristles shafts than that of said other brush. 20

8. A submarine cleaner including a chassis adapted to be submerged beneath the liquid in a tank for cleaning the bottom surface of the tank, said cleaner comprising,  
two rotatably mounted brushes operatively connected to said chassis, 25  
means for rotating said brushes,  
said rotatable brushes being in engagement with the bottom surface of the tank for cleaning said bottom surface and driving said cleaner over said bottom surface, said rotatable brushes being the only powered drive means in contact with the bottom surface of said tank, 30  
and means for removing foreign matter agitated by said brushes;  
one of said brushes having greater weight to support than said other brush. 35

9. A submarine cleaner including a chassis adapted to be submerged beneath the liquid in a tank for cleaning the bottom surface of the tank, said cleaner comprising,  
two rotatably mounted brushes operatively connected to said chassis, 40  
means for rotating said brushes,  
said rotatable brushes being in engagement with the bottom surface of the tank for cleaning said bottom surface and driving said cleaner over said bottom surface, said rotatable brushes being the only powered drive means in contact with the bottom surface of said tank, 45  
means for removing foreign matter agitated by said brushes; at least one of said brushes having an axis extending at an angle to the vertical,  
and a wheel means supporting a part of the weight of said chassis. 50

10. A submarine cleaner including a chassis adapted to be submerged beneath the liquid in a tank for cleaning the bottom surface of the tank, said cleaner comprising,  
two rotatably mounted brushes operatively connected to said chassis, 55  
means for rotating said brushes,  
said rotatable brushes being in engagement with the bottom surface of the tank for cleaning said bottom surface and driving said cleaner over said bottom surface, said rotatable brushes being the only powered drive means in contact with the bottom surface of said tank, 60  
means for removing foreign matter agitated by said brushes; each of said brushes having its axis at an angle to the vertical,  
and a swivel wheel means supporting a part of the weight of said chassis. 70

11. A submarine cleaner including a chassis adapted to be submerged beneath the liquid in a tank for cleaning the bottom surface of the tank, said cleaner comprising, 75

6

two rotatably mounted brushes operatively connected to said chassis,  
means for rotating said brushes,  
said rotatable brushes being in engagement with the bottom surface of the tank for cleaning said bottom surface and driving said cleaner over said bottom surface, said rotatable brushes being the only powered drive means in contact with the bottom surface of said tank,  
means for removing foreign matter agitated by said brushes;  
said brushes having their axes at an angle to each other, and a filter means capable of being imposed in said means for removing foreign matter.

12. A submarine cleaner including a chassis adapted to be submerged beneath the liquid in a tank for cleaning the bottom surface of the tank, said cleaner comprising,  
two rotatably mounted brushes operatively connected to said chassis, 10  
a pump capable of acting as a motor when suction is applied to it,  
said rotatable brushes being in engagement with the bottom surface of the tank for cleaning said bottom surface and driving said cleaner over said bottom surface, said rotatable brushes being the only powered drive means in contact with the bottom surface of said tank, 15  
means for connecting said brushes to said pump for rotating said brushes,  
and means for removing foreign matter agitated by said brushes; at least one of said brushes having its axis at an angle to the vertical.

13. A submarine cleaner including a chassis adapted to be submerged beneath the liquid in a tank for cleaning the bottom surface of the tank, said cleaner comprising, a compartment,  
two rotatably mounted brushes operatively connected to said chassis and below said compartment, 20  
a pump means having an inlet and an outlet opening and adapted to being actuated by either a prime mover or by suction,  
means for operatively connecting said brushes to said pump means whereby when said pump means is actuated said two brushes will be rotated,  
said rotatable brushes being in engagement with the bottom surface of the tank for cleaning said bottom surface and driving said cleaner over said bottom surface, said rotatable brushes being the only powered drive means in contact with the bottom surface of said tank, 25  
said compartment having an inlet opening and an outlet opening in communication with the tank and the inlet opening of said pump means,  
and a filter means operatively communicating with the inlet of said compartment.

14. A submarine cleaner including a chassis adapted to be submerged beneath the liquid in a tank for cleaning the bottom surface of the tank, said cleaner comprising, a compartment,  
two rotatably mounted brushes operatively connected to said chassis and below said compartment, 30  
a pump means having an inlet and an outlet opening and adapted to being actuated by either a prime mover or by suction,  
means for operatively connecting said brushes to said pump means whereby when said pump means is actuated said two brushes will be rotated;  
said rotatable brushes being in engagement with the bottom surface of the tank for cleaning said bottom surface and driving said cleaner over said bottom surface, said rotatable brushes being the only powered drive means in contact with the bottom surface of said tank, 35  
said compartment having an inlet opening and an out-



3,321,787

7

let opening in communication with the tank and the inlet opening of said pump means, and a detachable filter means operatively communicating with the inlet of said compartment.

15. A submarine cleaner including a chassis adapted to be submerged beneath the liquid in a tank for cleaning the bottom surface of the tank, said cleaner comprising, a compartment, two rotatably mounted brushes operatively connected to said chassis and below said compartment, a pump means having an inlet and an outlet opening and adapted to being actuated by either a prime mover or by suction, means for operatively connecting said brushes to said pump means whereby when said pump means is actuated said two brushes will be rotated; said rotatable brushes being in engagement with the bottom surface of the tank for cleaning said bottom surface and driving said cleaner over said bottom surface, said rotatable brushes being the only powered drive means in contact with the bottom surface of said tank, said compartment having an inlet opening and an outlet opening in communication with the tank and the inlet opening of said pump means, and a detachable filter means operatively communicating with the inlet of said compartment and in said compartment.

16. A submarine cleaner including a chassis adapted to be submerged beneath the liquid in a tank for cleaning the bottom surface of the tank, said cleaner comprising, a brush operatively rotatably mounted on said chassis, a pump means on said chassis having an inlet and an outlet, a sealed electric motor on said chassis having its driving shaft operatively connected to said pump means and said brush, said rotatable brush being in engagement with the bottom surface of the tank for cleaning said bottom surface and driving said cleaner over said bottom surface, said rotatable brush being the only powered drive means in contact with the bottom surface of said tank, and a foreign matter collecting means associated with said pump means; said outlet of said pump capable of serving to jet a stream of water for propelling said chassis over the floor of a swimming pool.

17. A submarine cleaner including a chassis adapted to be submerged beneath the liquid in a tank for cleaning the bottom surface of the tank, said cleaner comprising,

8

two rotatably surface engaging elements operatively connected to said chassis, means for rotating said surface engaging elements, said rotatable surface engaging elements being in engagement with the bottom surface of the tank for cleaning said bottom surface and driving said cleaner over said bottom surface, said rotatable surface engaging elements being the only powered drive means in contact with the bottom surface of said tank, and means for removing foreign matter agitated by said surface engaging elements; each of said surface engaging elements having an axis at an angle to the vertical.

18. In a swimming pool cleaning means, a chassis having a compartment, two rotatably mounted surface engaging members operatively connected to said chassis and below said compartment, an electric motor on said chassis having a drive shaft, a pump means operatively connected to the drive shaft of said electric motor and having an outlet opening and an inlet opening; said inlet opening communicating with the inside of said compartment, a conduit connected to the outlet of said pump means and communicating outside said compartment, means for operatively connecting the drive shaft of said electric motor to said surface engaging members; said compartment having an inlet opening communicating with the underside of said compartment adjacent said surface engaging members, and a removable foreign matter collecting filter means in said compartment and detachably operatively connected to said inlet opening of said compartment.

References Cited

UNITED STATES PATENTS

1,081,209	12/1913	Carr	15—340 X
1,677,533	7/1928	Staehle	15—49 X
1,891,175	12/1932	Peterson	15—328
2,246,036	6/1941	Farrell	15—387
2,671,926	3/1954	Minerley	15—387
3,186,021	6/1965	Krier et al.	15—340

FOREIGN PATENTS

758,796	11/1933	France.
---------	---------	---------

CHARLES A. WILLMUTH, *Primary Examiner*,

E. L. ROBERTS, *Examiner*.

# **EXHIBIT**

# **1002**

**United States Patent** [19]

[11] **3,936,899**

**Henkin et al.**

[45] **Feb. 10, 1976**

[54] **AUTOMATIC SWIMMING POOL CLEANER**

[57] **ABSTRACT**

[76] Inventors: **Melvyn L. Henkin**, 19640 Greenbriar Drive, Tarzana, Calif. 91356; **Jordan M. Laby**, 3940 Davana Road, Sherman Oaks, Calif. 91403

An automatic swimming pool cleaner comprised of a car adapted to travel underwater along a random path on the pool vessel surface for dislodging debris therefrom. The car wheels are driven by a water powered turbine to propel the car in a forward direction, along the vessel surface. In order to prevent the car from being driven into a position, as for example against a vertical wall, from which it cannot emerge, a wheel geometry is employed which, upon contact, develops a horizontal force component parallel to the vertical wall, to thus enable the car to spin off. Alternatively, or in combination, a water flow produced reaction force can produce a torque to turn the car with respect to the engaged wheel to enable the car to spin off. The car is designed with a low center of gravity and a relatively buoyant top portion so as to produce a torque which maintains the car correct side up when on the pool bottom. Means are provided on the car for producing a water flow having force component perpendicular to the vessel surface to provide good traction between the car wheels and the vessel surface. Further, a water flow produced suction is created adjacent to the vessel surface for collecting debris into a basket carried by the car. In addition, one or more hoses is pulled by the car and whipped by water flow to sweep dirt from the vessel surface.

[22] Filed: **Mar. 7, 1974**

[21] Appl. No.: **448,817**

**Related U.S. Application Data**

[62] Division of Ser. No. 275,173, July 26, 1972, abandoned.

[52] **U.S. Cl.** ..... **15/1.7**

[51] **Int. Cl.<sup>2</sup>** ..... **F04H 3/20**

[58] **Field of Search** ..... **15/1.7, 387; 114/222; 180/1 R, 1 VS, 7 T, 66 R**

[56] **References Cited**

**UNITED STATES PATENTS**

1,466,315	8/1923	Thorsen .....	15/1.7 UX
2,314,675	3/1943	Wilson .....	180/66 R
3,238,549	3/1966	Burlin et al. ....	15/1.7
3,551,930	1/1971	Myers .....	15/1.7

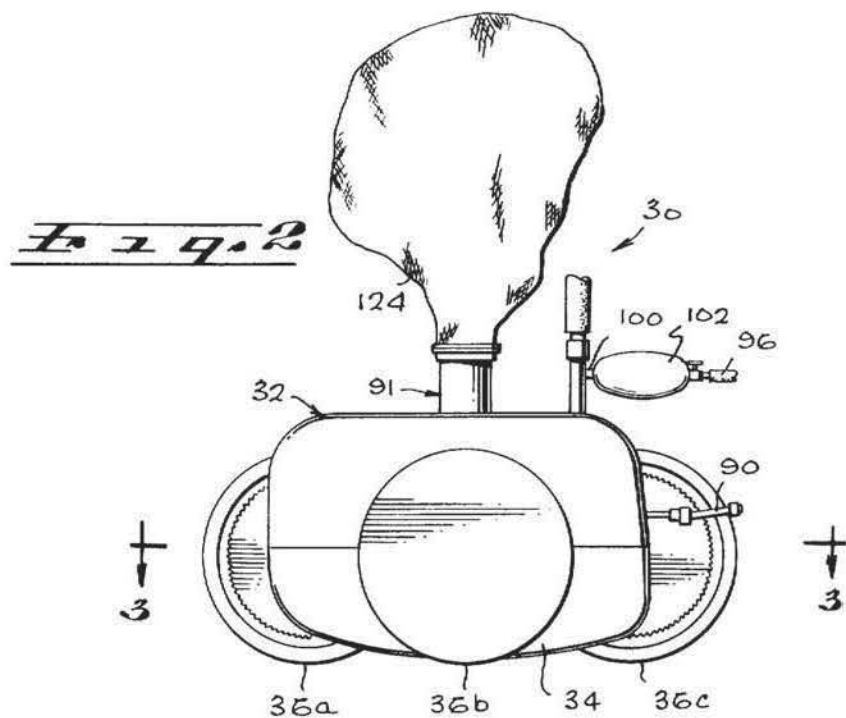
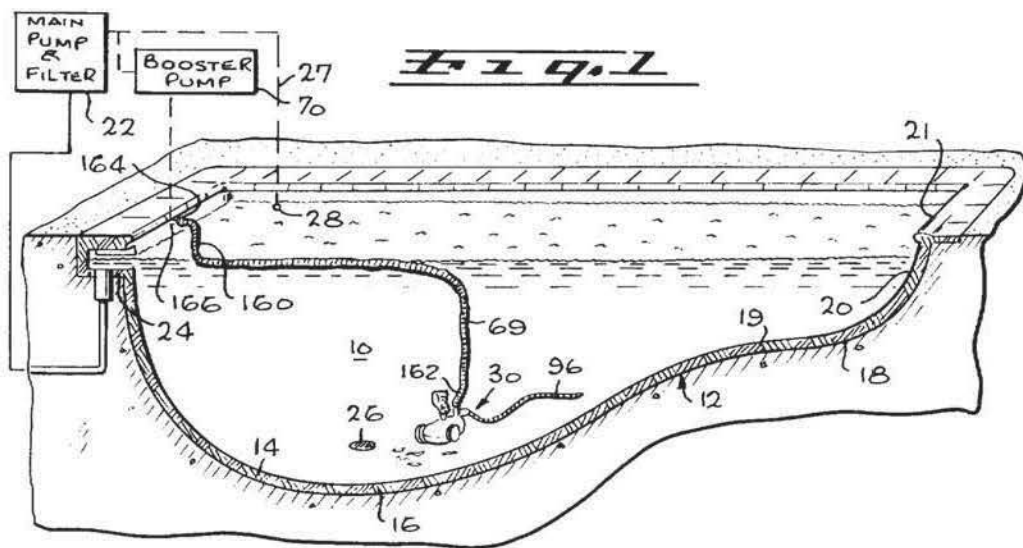
**FOREIGN PATENTS OR APPLICATIONS**

9648/27	9/1927	Australia.....	15/1.7
---------	--------	----------------	--------

*Primary Examiner*—Edward L. Roberts  
*Attorney, Agent, or Firm*—Lindenberg, Freilich, Wasserman, Rosen & Fernandez

**24 Claims, 10 Drawing Figures**

U.S. Patent Feb. 10, 1976 Sheet 1 of 4 3,936,899



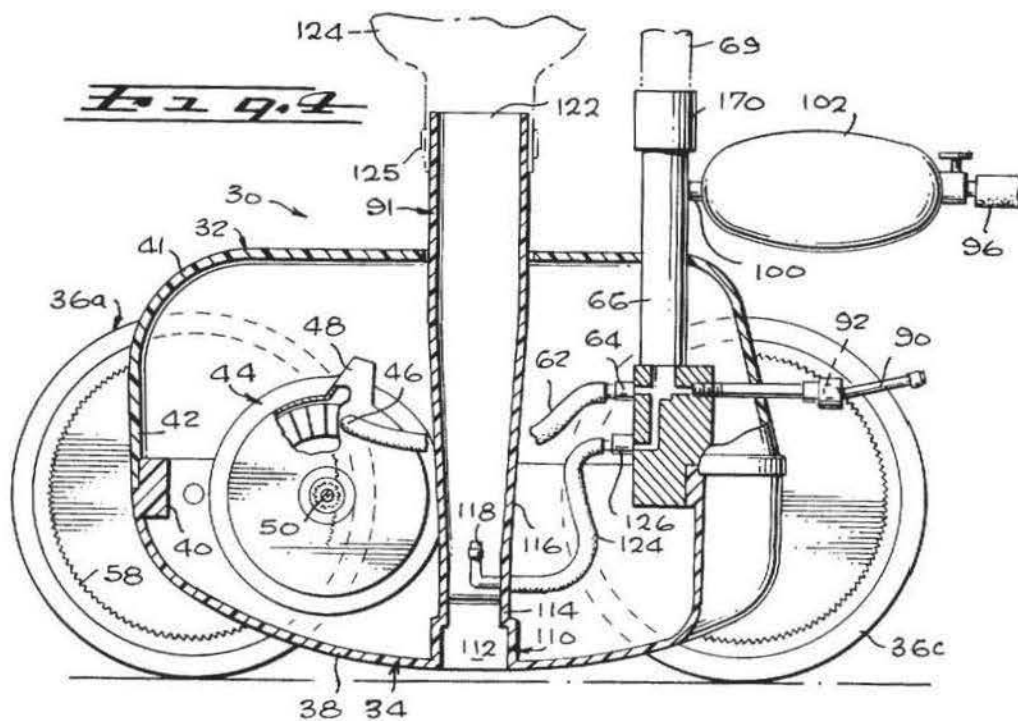
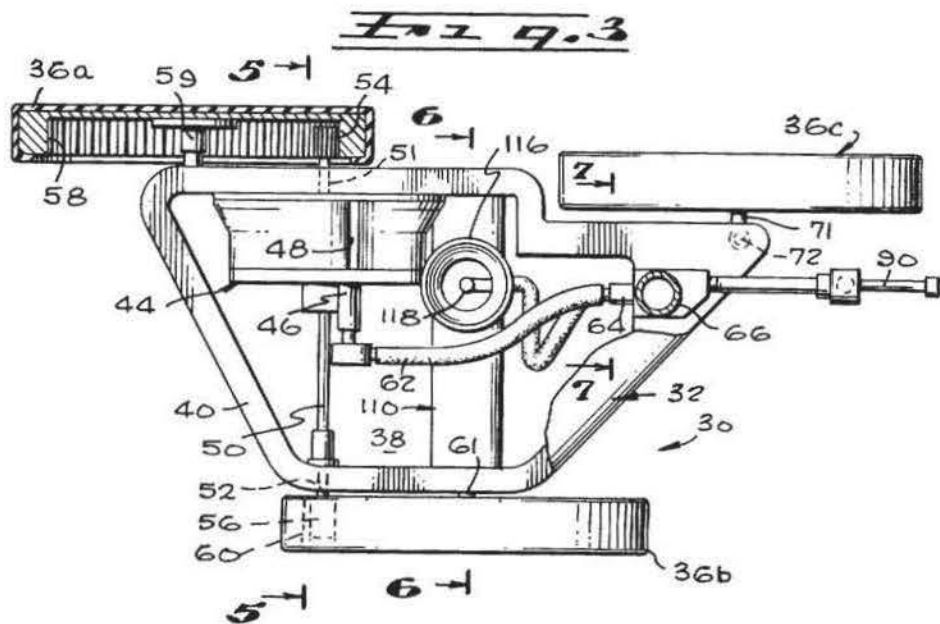


Fig. 5

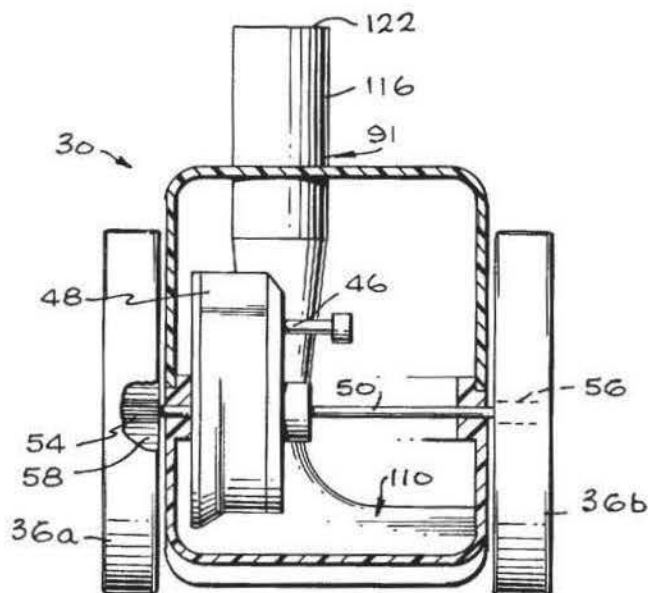


Fig. 7

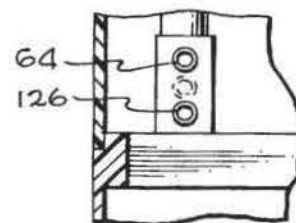
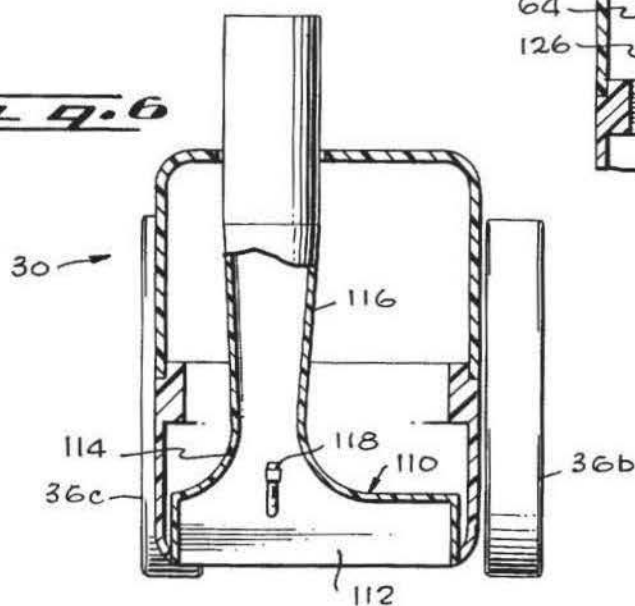
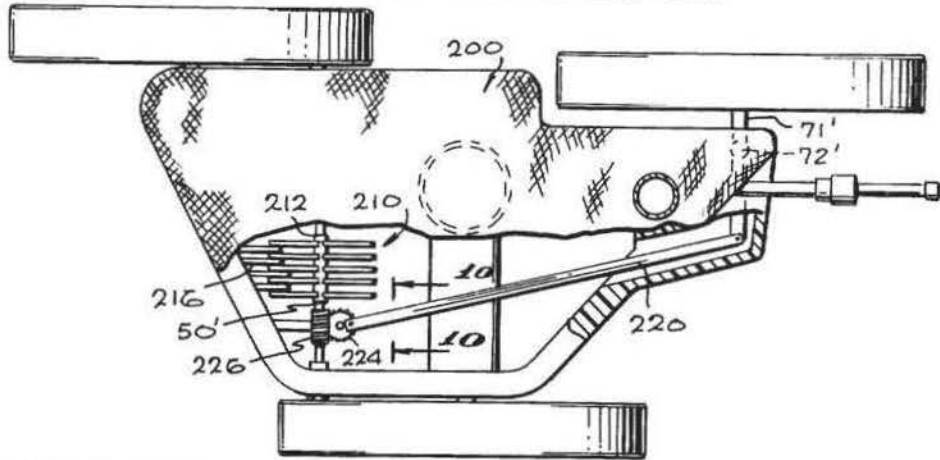


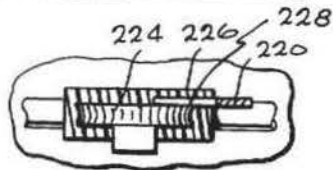
Fig. 6



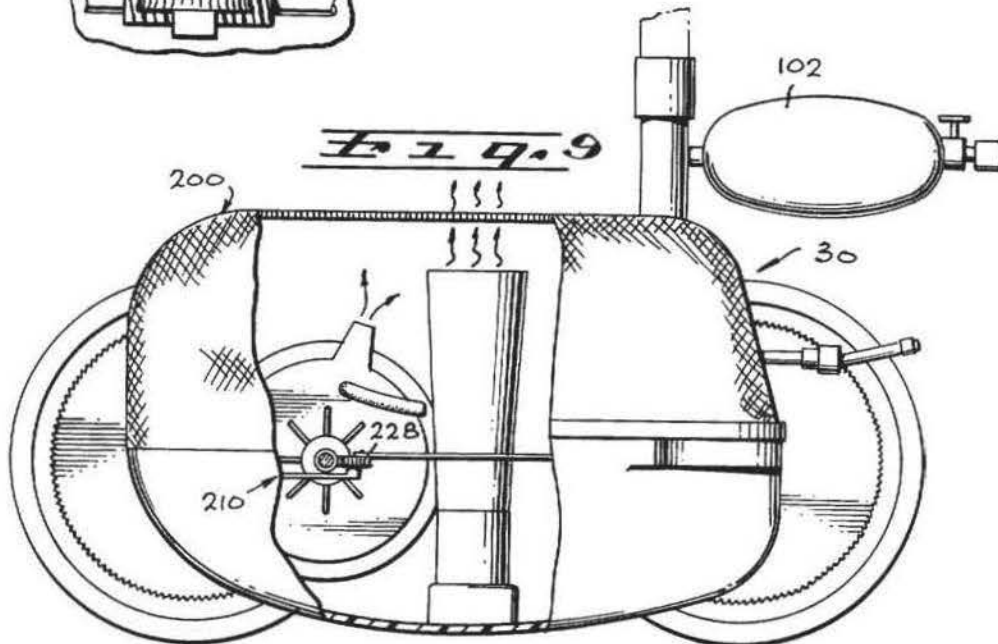
**Fig. 8**



**Fig. 10**



**Fig. 9**



3,936,899

1

**AUTOMATIC SWIMMING POOL CLEANER**

This is a division of application Ser. No. 275,173, filed July 26, 1972, now U.S. Pat. No. 3,822,754.

**BACKGROUND OF THE INVENTION**

This invention relates generally to an automatic swimming pool cleaner and more particularly to a cleaner comprised of a car adapted to travel underwater along a random path on the surface of a pool vessel.

Many different types of apparatus are disclosed in the prior art for cleaning swimming pools. An example of U.S. Pat. No. 3,291,145 which discloses a cleaner employing a floating head carrying high pressure liquid dispensing hoses which sweep the pool vessel walls so as to put any dirt thereon in suspension where it can be filtered out by the pool's standard filtration system. As further examples, U.S. Pat. No. 2,923,954 and 3,108,298 disclose cleaners in which wheeled vehicles move underwater along the pool vessel surface to collect debris and sweep the walls.

Prior art underwater cleaners have thus far met with only limited success for several reasons. Initially, in order to develop adequate traction between the wheels and pool vessel surface, they have typically had to be very heavy and cumbersome. Moreover, those underwater cleaners which employ an electric motor have proved to be somewhat inconvenient because of the potential shock hazard. That is, since it is normally recommended that the motor not be operated while there are swimmers in the pool, the cleaner cannot safely be left in the pool under the control of a time clock. As a consequence, the use of such cleaners has, for the most part, been restricted to commercial applications.

Further, it is characteristic of most prior art underwater cleaners to utilize relatively complex reversing and steering mechanisms in order to achieve adequate surface coverage. Such complex mechanisms are generally costly and relatively unreliable.

In view of the foregoing, it is an object of the present invention to provide an improved underwater swimming pool cleaner.

**SUMMARY OF THE INVENTION**

Briefly, the present invention is directed to a swimming pool cleaner including a car adapted to travel underwater along a random path on the pool vessel surface. The car is supported on power driven wheels which frictionally engage the vessel surface to drive it in a forward direction. In accordance with an improvement aspect of the invention, means are provided on the car for developing one or more water flows having a force component perpendicular to a plane tangential to the wheels and vessel surface. The water flows can, in addition, produce a forwardly directed force component which aids in propulsion and facilitates the climbing or spinning off of a vertical surface when encountered.

In accordance with a further aspect of the invention, a car wheel geometry is employed which produces a sidewise force component when the car wheels engage a vertical surface to thus cause the car to spin off and free itself from the surface without necessitating a reversal of driving direction.

In accordance with a still further aspect of the invention, the car structure is configured so that its center of gravity is close to the bottom of its vertical dimension

2

so as to produce a torque tending to maintain it correct side up when on the pool bottom.

In accordance with a still further aspect of the invention, one or more hoses are coupled to the car and whipped by water flow therethrough to sweep the vessel surface and put any dirt thereon in suspension.

In accordance with a still further aspect of the invention, means are provided on the car for producing a suction adjacent to the vessel surface for pulling debris into a collection basket or bag carried by the car.

In a preferred embodiment of the invention, the car is formed of a platform supported on three wheels which engage the pool vessel surface. Two of the wheels are driven through gearing by a turbine which in turn is powered by water flowing thereto through a supply hose. In order to achieve the aforementioned spinoff effect, the two driven wheels are mounted for rotation about parallel, but spaced, axes. As a consequence, the leading edges of the driven wheels lie on a line which is not perpendicular to their direction of travel thus enabling the car to spin off obstructions and steep surfaces. The third wheel is mounted for rotation on an axis which pivots in a plane parallel to the plane tangential to the wheels so that this third wheel may be differently oriented for different pool surface slopes, thereby helping to randomly steer the car. Alternatively, positive drive means such as a linkage to the turbine can be provided to gradually pivot the third wheel or vary the discharge angle of a water jet to assure random car movement.

The water flow producing a force component perpendicular to the vessel surface is preferably developed by diverging a low volume, high velocity water flow from the supply hose to an orifice to thus pull water into the lower end of a venturi having a directional component extending perpendicular to the car platform which water is then discharged at the venturi's upper end. The force reaction presses the wheels against the pool vessel surface to thus develop significantly greater traction for propulsion than the weight of the car alone could provide. As a consequence, the car can be constructed of relatively light and low cost materials and have the capability of climbing vertical surfaces. The suction produced adjacent the vessel surface by the water being pulled into the lower tube end draws debris from the pool surface into a collection basket carried by the car. Although a single water flow is used in the preferred embodiment of the invention for providing the primary hold down force as well as suction for picking up debris, it will be readily recognized that separate flows could be provided for this purpose if desired.

In accordance with another aspect of the invention, a portion of the water supply is diverted through the trailing sweep hoses to randomly whip them against the pool vessel surface.

In accordance with a still further aspect of the invention, means are provided within the collection basket for pulverizing leaves so that the remains can then be discharged and put in suspension in the pool water for later removal by the main filter system.

**BRIEF DESCRIPTION OF THE DRAWINGS**

FIG. 1 is an isometric sectional view illustrating a pool cleaner in accordance with the present invention in a typical swimming pool;

FIG. 2 is a side elevation view of a preferred embodiment of the present invention;



3,936,899

3

FIG. 3 is a sectional view of a pool cleaner in accordance with the present invention taken substantially along the plane 3—3 of FIG. 2;

FIG. 4 is a side view, partially broken away, of a pool cleaner in accordance with the present invention;

FIG. 5 is a sectional view taken substantially along the plane 5—5 of FIG. 3;

FIG. 6 is a sectional view taken substantially along the plane 6—6 of FIG. 3;

FIG. 7 is a sectional view taken substantially along the plane 7—7 of FIG. 3;

FIG. 8 is a plan view partially broken away illustrating an alternative arrangement including a linkage coupling the turbine to the third wheel to cause random steering and a means for pulverizing leaves and other debris sucked into the collection basket;

FIG. 9 is a side elevation, partially broken away, of the pool cleaner of FIG. 8; and

FIG. 10 is a sectional view taken substantially along the plane 10—10 of FIG. 8.

#### DESCRIPTION OF THE PREFERRED EMBODIMENT

Attention is now called to FIG. 1 which illustrates a cutaway isometric view of a typical residential or commercial swimming pool. The water 10 is contained within a vessel 12 generally defined by a reinforced concrete wall 14 poured to conform to the shape of an excavated hole. Typically, a hole is excavated which defines a relatively deep end 16 and a relatively shallow end 18. In conforming to the shape of the excavation, the wall 14 generally defines substantially horizontal or floor portions 19 as well as substantially vertical or wall portions 20 which rise above the intended level of the water 10 to decking or coping 21.

Typically, filtration systems employed with swimming pools of the type illustrated in FIG. 1 include a main pump and filter 22 for taking water from the pool, filtering the water, and returning the filtered water to the pool. Such filtration systems employ water intake ports, such as a surface or skimmer intake 24 and a below water level drain intake 26. The filtration system sucks water into the intakes 24 and 26, and after filtration, returns the water to the pool via a return line 27 and return ports 28 extending through the vertical wall portion 20 close to the water line.

Although the typical swimming pool filtration system does quite an adequate job of filtering the water to remove fine debris particles suspended therein, such systems are not effective to remove debris, such as leaves, which settle on the floor of the panel or fine particles of debris which settle on both the floor and vertical wall portions of the pool vessel surface. As a consequence, in order to maintain a swimming pool clean, it is necessary to periodically sweep the wall surface, as with a longhanded brush, to place any fine debris in suspension. Additionally, it is also necessary to periodically vacuum the pool floor to remove larger debris such as leaves.

The present invention is directed to a cleaning apparatus 30 which travels along a random path on the surface of the pool vessel to both sweep the walls and suck debris into a debris container carried thereby.

Attention is now called to FIGS. 2-7 which illustrate a preferred embodiment of pool cleaner in accordance with the present invention.

The pool cleaner 30 is comprised of a car 32 having a frame or body structure 34 supported on some type of

4

movable traction means such as wheels 36a, 36b, 36c. As shown in FIG. 4, the frame structure 34 can be essentially pan shaped, consisting of a bottom plate or platform 38 and upstanding sidewall 40 extending around the periphery thereof. A dome or cover member 41 is provided having depending sidewalls 42 which mate with upstanding sidewall 40.

In accordance with the present invention, a turbine mechanism 44 is mounted within the frame structure 34 for producing rotary motion in response to a pressured water/flow supplied thereto. The turbine 44 can be conventional in design having a water inlet port 46, a water outlet port 48, and a power output shaft 50 which is rotated in response to water being supplied to the port 46.

The output shaft 50 extends axially in both directions from the turbine 44 and is supported for rotation in openings through wall portions 51, 52. Small gears 54, 56 are secured to the shaft 50 at opposite ends thereof. The gear 54 is engaged with an annular rack 58 formed on the inner surface of wheel 36a as is best shown in FIGS. 3 and 4. The wheel 36a is mounted for rotation on axle 59 which extends parallel to, but is spaced from, shaft 50. The gear 56 is similarly engaged with annular rack 60 formed on the inner surface of wheel 36b mounted for rotation on axle 61. Axle 61 also extends parallel to shaft 50 but is spaced therefrom in the direction opposite from axle 59. In contrast to the drive or traction function performed by wheels 36a and 36b, wheel 36c is merely a support wheel, as shown in FIGS. 3 and 4 mounted for rotation about axle 71. Axle 71 can be mounted for pivotal movement about pin 72 to better enable the wheel 36c to follow the contour of the vessel surface.

The turbine 44 is powered by water supplied to the port 46 via conduit 62 coupled to outlet 64 of a water supply manifold 66. A pressurized water/flow is supplied to the inlet 68 of the manifold 66 through a supply hose 69 preferably from a booster pump 70 (FIG. 1). As the turbine 44 rotates to drive the shaft 50, both the wheel 36a and the wheel 36b will rotate.

It will be noted from FIG. 3 that although the wheels 36a and 36b rotate about parallel axes, the axes are offset with respect to one another. In other words, a line projected between the axes of wheels 36a and 36b will be skewed with respect to the planes of rotation of the wheels. As a consequence of this skew arrangement, the car will avoid getting stuck against vertical walls or barriers. That is, in its random travel along the pool vessel surface, even if the wheels 36a and 36b simultaneously engage a large obstacle such as the vertical wall of a step, the skewed relationship of the wheels 36a and 36b relative to the direction of travel will produce a force component extending parallel to the vertical wall to thus enable the car to spin off and thus avoid getting stuck in a position from which it cannot emerge.

It will be recalled from FIG. 1 that the wall 14 of a typical pool is shaped with a relatively large radius of curvature between the substantially horizontal or floor portions of the pool vessel and the substantially vertical or sidewall portions. In other words, for structural integrity and to facilitate water flow, many modern pools are not constructed with sharp corners between floor and wall. In order to most effectively clean a pool, it is desirable of course that the car be able to traverse as much of the pool vessel surface as possible. In other words, it is desirable that the car be able to climb the

3,936,899

5

substantially vertically oriented portions of the pool vessel wall. In order to accomplish this, the car 32 in accordance with the present invention is provided with water powered means for producing a thrust to increase traction between the wheels 36 and the vessel surface. In accordance with the preferred embodiment of the invention, this thrust is produced by a water jet discharged from a directionally adjustable nozzle 90 and by a water stream discharged from a suction or vacuum unit 91. The two thrust components produce a substantial force extending normal to the vessel surface thereby increasing traction between the wheels 36a, 36b, 36c and the vessel surface and enabling the car to climb vertical surfaces.

The nozzle 90 is preferably mounted on some type of universal fitting such as a ball coupling 92 which couples the nozzle to the supply manifold 66 for receiving a high pressure water supply from booster pump 70. The angle of the nozzle 90 is selected to yield both a downward thrust component (i.e. normal to the vessel surface) for providing traction and a forward component which aids in propelling the car and facilitates the car climbing vertical surfaces and working itself out of corners. Set means (not shown) can be provided for holding the selected angle of the nozzle and valve means (not shown) can be provided for varying the flow rate through the nozzle 90.

In use, as the car is propelled along the vessel surface by rotation of the drive wheels 36a and 36b, the vacuum unit 91 will always discharge a water flow having a component normal to the portion of the vessel surface on which the car then rests. The intensity of the water flow is selected to produce a reaction force sufficient to enable the car to climb vertical surfaces. As the car climbs, the combined effects of gravity, the cars inherent flotation characteristics and the directional variations produced by the water jet (and other effects to be discussed) cause a change in direction of travel causing the car to fall off the vertical surface and reestablish its travel along another path. In order to assure that the car lands correct side up, the car is designed to have a relatively low center of gravity; i.e. the weight distribution of the car is selected so that its center of gravity is close to the bottom of its vertical dimension, so as to thereby produce a bouyant torque tending to maintain its correct side up. The entire car structure is preferably designed to weigh very little when underwater, thereby assuring that the hold down force produced by the water flow together with the weight distribution of the car, will cause the car to land correct side up whenever it falls from a wall surface.

The car carries with it one or more sweep hoses 96 which are trailed along and whip against the vessel surface. More particularly, a hose 96 is coupled to a tube 100 communicating with the interior of the supply manifold 66. The remote end of the hose 96 is left open via an orifice. Water flowing from the manifold 66 and tube 100 through the hose 96 will exit through the open hose end and in so doing will produce a reaction force on the hose whipping it in random directions. As a consequence, it will rub against and sweep fine debris from the vessel surface, putting it in suspension for removal by the pools standard filtration system. A float 102 is preferably mounted around the tube 100 to facilitate dynamic balance of the car. A valve 104 is preferably incorporated in the tube 100 for controlling the flow rate to the sweep hose and thus the whipping action thereof.

6

In the course of moving along a random path on the pool vessel surface in a manner thus far described, it is of course the function of the cleaner to clean the surface as by putting fine debris thereon in suspension for removal by the standard filtration system.

In addition, in accordance with the invention, large debris such as leaves are collected by the subject cleaner by the vacuum unit 91 which produces a suction close to the pool vessel surface. More particularly, a suction or vacuum head 110 (FIGS. 3 and 4) extending across substantially the full width of the car between the wheels 36a and 36b is defined in the plate 38. The suction head 110 defines a suction opening 112 at the bottom thereof. The opening 112 narrows down and communicates with the lower end 114 of a venturi tube 116. An orifice 118 is mounted in the thrust of the venturi tube 116 for discharging a flow of water there-through toward the open end 122 of the venturi tube. Orifice 118 receives water flow via conduit 124 coupled to outlet 126 on the supply manifold 66. As should be appreciated, the water discharged from the orifice 118 produces a reduced pressure in the throat area of the venturi tube thus producing a suction at the entrance opening 112. As a consequence, water and debris are drawn from the vessel surface into the opening 112 and through the venturi tube 116. The water and debris are then discharged through the open venturi end 122 into a debris collection container. In the embodiment of the invention illustrated in FIGS. 2-7, the debris collection container constitutes a bag 124 formed of mesh material having an entrance opening sealed around the open end 122 of the venturi tube 116 by a band 125. The bag 124 is of course removable from the venturi tube 116 for cleaning or disposal.

Reference was previously made to a supply hose 69 for supplying a pressurized water flow to the manifold 66. In order to assure that the car does not get entangled with the supply hose 69, it is preferable that the hose float during operation as is represented in FIG. 1. The hose of course can be cause to float by mounting suitable floats thereon. More particularly, the supply hose 69 can comprise a one-half inch inner diameter plastic hose, for example, having a swivel coupling 164 mounted in a first end 160 thereof. The swivel coupling 164 is adapted to be threaded into an outlet 166 provided in the pool vessel surface adjacent to the water surface. A water booster pump 70 which can divert water out of the pool's standard filtration system, provides a high pressure flow to the outlet 166. The second end 162 of the hose 69 is coupled by a similar swivel coupling 170 to the previously mentioned supply manifold 66.

From the foregoing, it will be recognized that a swimming pool cleaner has been disclosed herein which is comprised of a car which travels along a random path on the surface of a pool vessel propelled by traction wheels powered by a water driven turbine. As a consequence of employing the previously discussed water streams to produce a significant traction force between the wheels and the vessel surface, the car can be constructed of light-weight inexpensive materials, such as plastic. By being able to utilize light weight materials such as plastic, a car in accordance with the invention can be produced quite inexpensively. Moreover, by designing the car so as to assure full coverage of the pool vessel surface without requiring complex steering and reversing mechanisms, cost reduction and reliability improvement is further enhanced. Although a par-

3,936,899

7

tical embodiment of the invention has been illustrated in FIGS. 2-7, it should be readily apparent that many variations can be made without departing from the spirit or scope of the invention. Thus, for example only, an alternative arrangement is shown in FIGS. 8-10 wherein, in lieu of utilizing a separate debris collection bag, the car structure itself forms the debris container with the car cover member 200 being perforated to permit water flow therethrough.

Utilization of the arrangement of FIGS. 8-10 contemplates that a user remove the dome 200 and then clean the debris from the pan shaped frame structure. In both the arrangement of FIGS. 8-10 and the arrangement of FIGS. 2-7, the mesh size for the water permeable material should be selected to suit a particular set of conditions. For example, in pool situations where many leaves are encountered, it would be desirable to utilize, material with relatively large holes so as to contain most of the leaves and enable the water to freely flow therethrough to suspend the rest of the debris for removal by the filter system. On the other hand, a pool with few leaves but a heavy silt problem would preferably use a very closely woven container material to remove the silt and reduce the load on the filter system.

In using the subject pool cleaner, it has been recognized that as the leaves collect within the container, the high velocity water stream discharged from the upper end of the venturi tube continually beats the leaves against the container screen material. As a consequence, the leaves are pulverized into fine particles which pass through the screen material and go into suspension in the water from which they can be removed by the pools regular filtration system. As a result of this action, the frequency with which the debris must be removed from the container is considerably reduced. In pool situations with a greater than normal leaf problem a pulverizing means 210 (FIGS. 8 and 9) can be incorporated in the container to more positively pulverize the leaves. More particularly, as shown in FIG. 8 a collar 212 carrying a plurality of radially extending blades 214 can be mounted on turbine shaft 50'. As the shaft 50 rotates, the blades 214 move past fixed blade 216 shredding leaves therebetween.

In order for the pool cleaner to function effectively, it should travel in a highly random manner so as to substantially cover the entire vessel surface. Various factors operating on the car depicted in FIGS. 2-7 will tend to produce this random motion. Such factors include the vessel surface terrain, the action of the whip hose 96 and the direction of the nozzle 90. However, it is recognized that if necessary, for certain pool situations, means can be incorporated in the car for positively randomizing the car motion. For example, attention is called to FIGS. 8-10 which illustrates one such means for varying the plane of rotation of the wheel 36c as the car moves. In the embodiment of FIGS. 8-10, the axle 71' of the wheel 36c is pivoted around pin 72' by a link 220 coupled between the axle 71' and gear 224. The gear 224 is engaged with worm gear 226 secured to turbine shaft 50'. As shaft 50' rotates, gears 224 and 226 rotate around their axes thus moving the end 228 of link 220 in a small circle. This alternately pulls and pushes the free end of axle 71' thus pivoting it about pin 72'.

It should be recognized that other arrangements can also be employed for achieving the random motion produced by the embodiment of FIGS. 8-10. For exam-

8

ple only, the direction of the nozzle 90 can be varied as the car moves, a movable rudder can be employed and/or the flow rate through the sweep hose can be varied.

From the foregoing, it will be recognized than an improved swimming pool cleaner has been disclosed herein which is capable of randomly traveling on the pool vessel surface and collecting debris therefrom as well as dislodging debris from the surface for collection by the pools standard filtration system. Although a preferred embodiment of the invention has been illustrated herein, it is recognized that numerous variations and modifications can be made therein without departing from the spirit and scope of the invention. Thus, for example only, tractions means other than the rough wheels can be employed for increasing traction area or for facilitating travel of the car over low obstructions, such as a hose. Similarly, means can be provided for changing drive direction in special pool situations where the car could get stuck against some obstacle. It should also be recognized that although the preferred embodiments of the invention illustrated herein employ a booster pump 70 for optimum performance, the booster pump could be eliminated in a low cost system and the turbine could be driven by water flow from the main pump.

What is claimed is:

1. A swimming pool cleaner including a car adapted to travel underwater on the surface of a pool vessel; said car including a frame supported on traction means for engaging said pool vessel surface; water supply means carried by said car having an inlet and at least one outlet; turbine means carried by said car coupled to said water supply means outlet; drive means coupling said turbine means to said traction means for drivingly rotating said traction means in response to water supplied to said turbine means for propelling said car along said vessel surface; thrust means carried by said car for producing a water flow having a component directed to produce a reaction force on said car acting to thrust said traction means against said pool vessel surface; debris container means and debris suction means carried by said car; said debris container means including an entrance opening; said debris suction means including a suction entrance located on said car in close proximity to said vessel surface and a suction exit coupled to said debris container means entrance opening.
2. The swimming pool cleaner of claim 1 wherein said debris suction means includes a venturi tube having an exit end coupled to said debris container means entrance opening and an entrance end located in close proximity to said vessel surface; said debris suction means further including an orifice coupled to one of said water supply means outlets and directed towards the throat of said venturi tube for discharging a water flow therein.
3. The swimming pool cleaner of claim 2 wherein said venturi tube is oriented to discharge said water flow in a direction having a component extending normal to said vessel surface.
4. The swimming pool cleaner of claim 1 wherein said debris container means is defined by a water permeable material.

A2523

3,936,899

9

5. A swimming pool cleaner, useful in a system employing a water pump for withdrawing water from a swimming pool and for returning a pressurized water supply flow, said cleaner comprising:

a frame structure supported on movable traction means adapted to engage the pool vessel surface; turbine means including a power output member supported on said frame structure; supply hose means for coupling said water supply flow from said water pump to said turbine means for driving said power output member; means coupling said power output member to said traction means for moving said frame structure in response to said water supply flow driving said power output member; thrust means supported on said frame structure and coupled to said supply hose means for discharging a portion of said water supply flow in a direction having a component extending normal to said vessel surface to produce a reaction force in a direction to increase the traction between said traction means and vessel surface; suction means carried by said frame structure and having a suction opening located to be in close proximity to said pool vessel surface; a water permeable debris container carried by said frame structure; and means communicating said suction opening with said debris container.

6. The swimming pool cleaner of claim 5 wherein said means communicating said suction opening with said debris container comprises a venturi tube; and means for discharging a portion of said water supply flow proximate to the throat of said venturi tube to produce a reduced pressure thereat.

7. The swimming pool cleaner of claim 5 including means mounted in said container for pulverizing debris.

8. The swimming pool cleaner of claim 7 wherein said means for pulverizing includes at least one movable blade coupled to said power output member.

9. In a swimming pool cleaning system including a car adapted to travel underwater on the surface of a pool vessel, the improvement comprising:

a debris container carried by said car and having an entrance opening;

debris suction means carried by said car including a suction entrance disposed in close proximity to said vessel surface and a suction exit coupled to said debris container means entrance opening; and pulverizing means mounted in said container for pulverizing debris.

10. A swimming pool cleaner comprising:

a car including a frame supported on wheel means for engaging the surface of a swimming pool vessel; propelling means carried by said car for propelling said car along said vessel surface;

said wheel means including first and second parallel wheels each mounted for rotation on said frame and offset with respect to one another so that a line projected between the axes thereof is skewed with respect to the planes of said first and second wheels, at least one of said wheels extending beyond said frame in the direction said car is propelled for engaging vertical surfaces of said swimming pool vessel; and

debris suction means carried by said car and including a suction entrance located on said car in close proximity to said vessel surface.

10

11. The swimming pool cleaner of claim 10 further including:

debris container means carried by said car and including an entrance opening; and wherein said debris suction means includes a suction exit coupled to said debris container means entrance opening.

12. The swimming pool cleaner of claim 11 wherein said debris container is formed of water permeable material.

13. The swimming pool cleaner of claim 11 further including:

pulverizing means mounted in said container for pulverizing debris.

14. A swimming pool cleaner comprising:

a car including a frame supported on traction means for engaging the surface of a swimming pool vessel; water supply means carried by said car having an inlet and an outlet;

propelling means carried by said car for propelling said car along said vessel surface;

thrust means carried by said car for producing a water flow having a component directed to produce a reaction force on said car acting to thrust said traction means against said pool vessel surface, said thrust means including a nozzle coupled to said water supply means outlet for discharging a water flow in a direction having a component extending normal to said vessel surface; and

debris suction means carried by said car and including a suction entrance located on said car in close proximity to said vessel surface.

15. The swimming pool cleaner of claim 14 including adjustable means for supporting said nozzle in different orientations.

16. The swimming pool cleaner of claim 14 wherein said debris suction means includes a tube having entrance and exit openings at opposite ends thereof, said tube entrance opening communicating with said suction entrance; and wherein

said thrust means nozzle is disposed in said tube for discharging a water flow from proximate to said tube entrance opening toward said tube exit opening to produce a suction at said tube entrance opening.

17. The swimming pool cleaner of claim 14 further including:

debris container means carried by said car and including an entrance opening; and wherein said debris suction means includes a suction exit coupled to said debris container means entrance opening.

18. The swimming pool cleaner of claim 17 wherein said debris container is formed of water permeable material.

19. The swimming pool cleaner of claim 17 further including:

pulverizing means mounted in said container for pulverizing debris.

20. A swimming pool cleaner comprising:

a car including a frame supported on traction means for engaging the surface of a swimming pool vessel; water supply means carried by said car having an inlet and first and second outlets;

propelling means carried by said car for propelling said car along said vessel surface, said propelling means including a nozzle coupled to said water supply means first outlet for discharging a water

3,936,899

11

flow having a component directed substantially parallel to said vessel surface; thrust means carried by said car including a nozzle coupled to said water supply means second outlet for discharging a water flow having a component directed normal to said vessel surface to produce a reaction force on said car acting to thrust said traction means against said vessel surface; and debris suction means carried by said car and including a suction entrance located on said car in close proximity to said vessel surface.

21. The swimming pool cleaner of claim 20 further including: debris container means carried by said car and including an entrance opening; and wherein said debris suction means includes a suction exit coupled to said debris container means entrance opening.

22. The swimming pool cleaner of claim 20 wherein said debris suction means includes a tube having entrance and exit openings at opposite ends thereof, said tube entrance opening communicating with said suction entrance; and wherein

said thrust means nozzle is disposed in said tube for discharging a water flow from proximate to said tube entrance opening toward said tube exit open-

12

ing to produce a suction at said tube entrance opening.

23. A swimming pool cleaner comprising: a car including a frame supported on traction means for engaging the surface of a swimming pool vessel; water supply means carried by said car having an inlet and first and second outlets; propelling means carried by said car for propelling said car along said vessel surface, said propelling means including means for discharging a water flow having a component directed substantially parallel to said vessel surface; and suction means carried by said car and including a suction entrance located on said car in close proximity to said vessel surface, said suction means including a tube having entrance and exit openings at opposite ends thereof, said tube entrance opening communicating with said suction entrance, and a nozzle disposed in said tube for discharging a water flow from proximate to said tube entrance opening toward said tube exit opening to produce a suction at said tube entrance opening.

24. The swimming pool cleaner of claim 23 wherein said nozzle is oriented to discharge said water flow in a direction having a component normal to said vessel surface to produce a reaction force acting to thrust said traction means against said vessel surface.

\* \* \* \* \*

30

35

40

45

50

55

60

65

# **EXHIBIT**

# **1003**

**United States Patent** [19]

[11] 4,100,641

**Pansini**

[45] Jul. 18, 1978

[54] **SWIMMING POOL CLEANERS**

[76] **Inventor:** Andrew L. Pansini, 180 Los Cerros Dr., Greenbrae, Calif. 94904

[21] **Appl. No.:** 699,304

[22] **Filed:** Jun. 24, 1976

[51] **Int. Cl.<sup>2</sup>** ..... E04H 3/20; A47L 5/00

[52] **U.S. Cl.** ..... 15/1.7; 180/1 R

[58] **Field of Search** ..... 15/1.7; 180/1 R, 66 R; 114/222; 134/167 C, 168 C

[56] **References Cited**

**U.S. PATENT DOCUMENTS**

3,822,754 7/1974 Henkin ..... 15/1.7 X

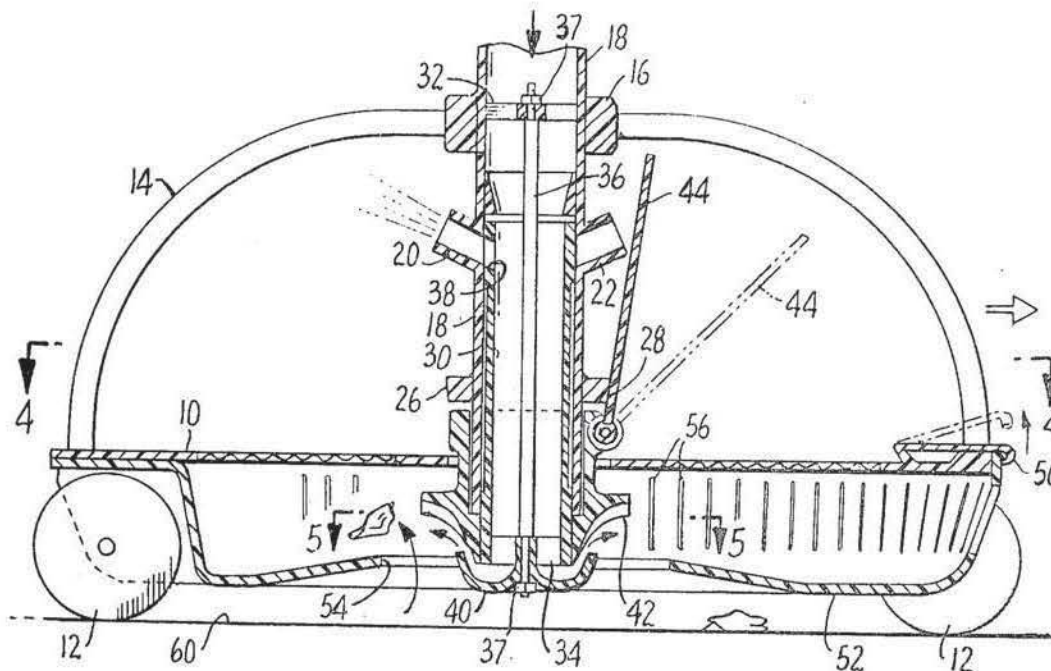
*Primary Examiner*—Edward L. Roberts

[57] **ABSTRACT**

A jet-powered submerged cleaner runs along the bottom of a pool and also up and down the side walls and does not require a booster pump for proper operation. It

travels on idler wheels and has a jet drive system which is under the control of pressure-responsive elements. The latter so operate that when the cleaner is sufficiently impeded against further movement in a given direction the jet drive system commences driving the cleaner in another direction. The cleaner discharges water under pressure in such a way that dirt is either vacuumed or blown free from adjacent pool wall surfaces, and the pressurized water is so directed and controlled as to cause the cleaner to be pressed against adjacent pool wall surfaces to thereby enable the cleaner to travel along and to climb inclined and vertical pool surfaces. A swivel connection is utilized to rotatably relate a pair of concentric tubes to minimize friction forces and enable foolproof operation of those embodiments of the cleaner which employ such concentric tubes.

20 Claims, 26 Drawing Figures



U.S. Patent

July 18, 1978 Sheet 1 of 9

4,100,641

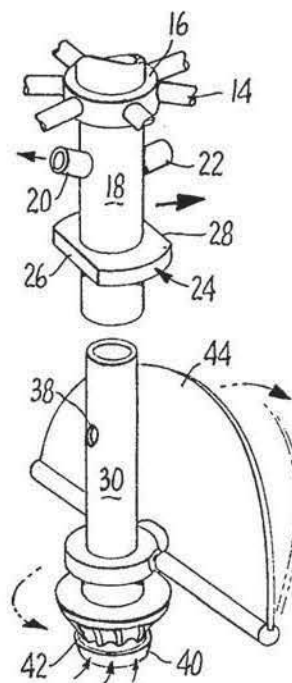
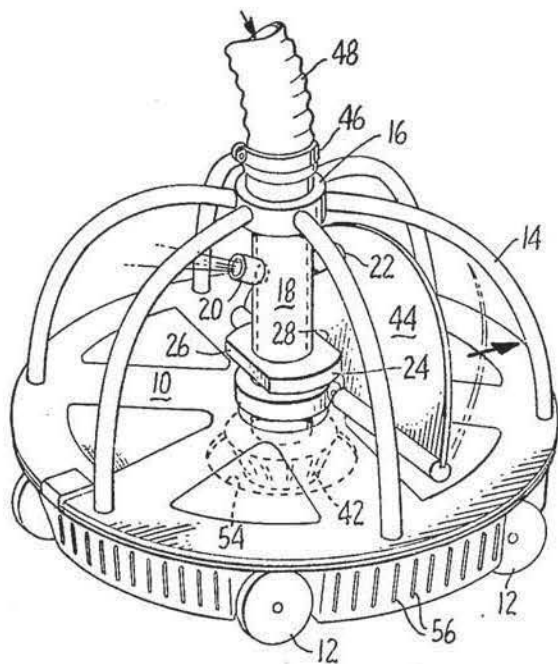


FIG. 1.

FIG. 2.

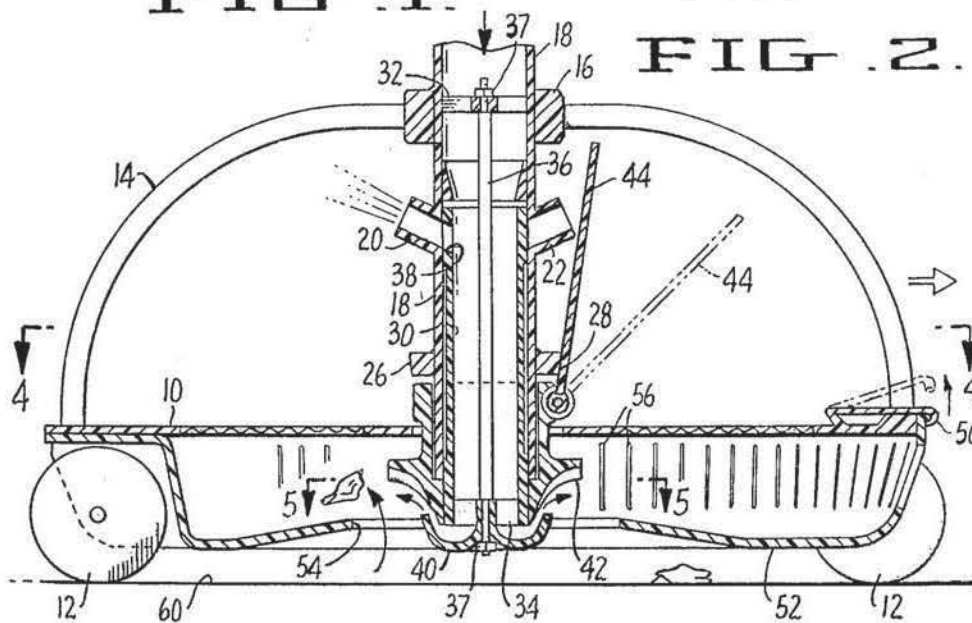


FIG. 3.



U.S. Patent

July 18, 1978 Sheet 2 of 9

4,100,641

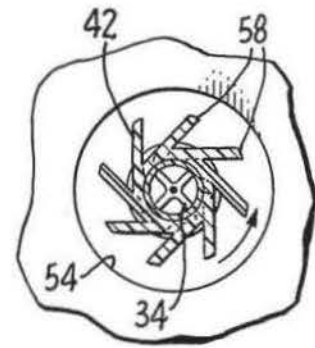
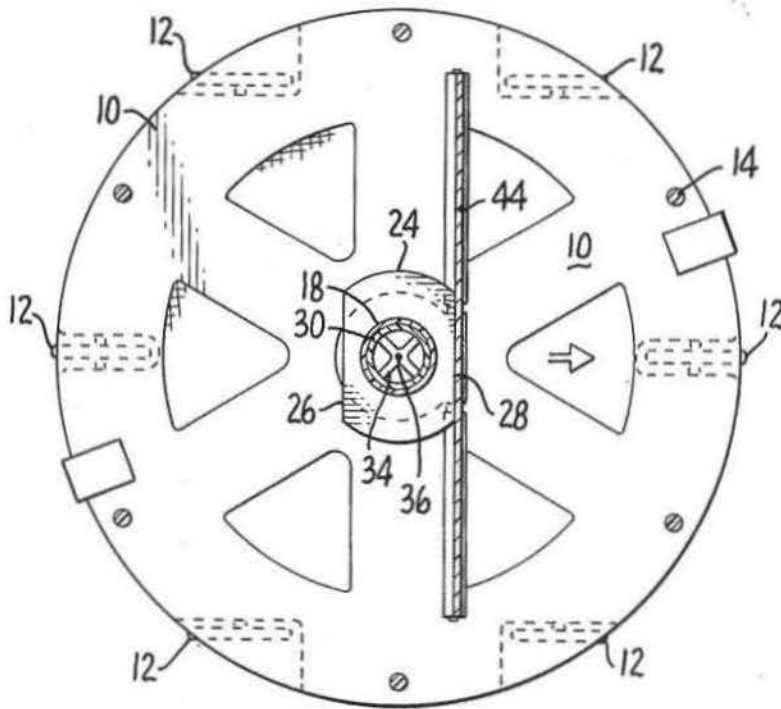


FIG. 5.

FIG. 4.

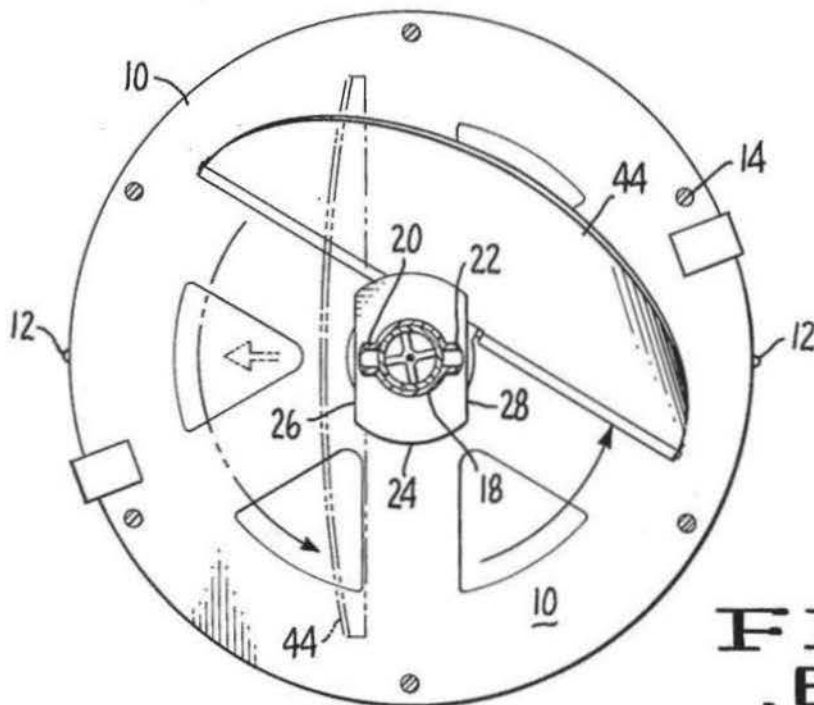


FIG. 6.

U.S. Patent

July 18, 1978

Sheet 3 of 9

4,100,641

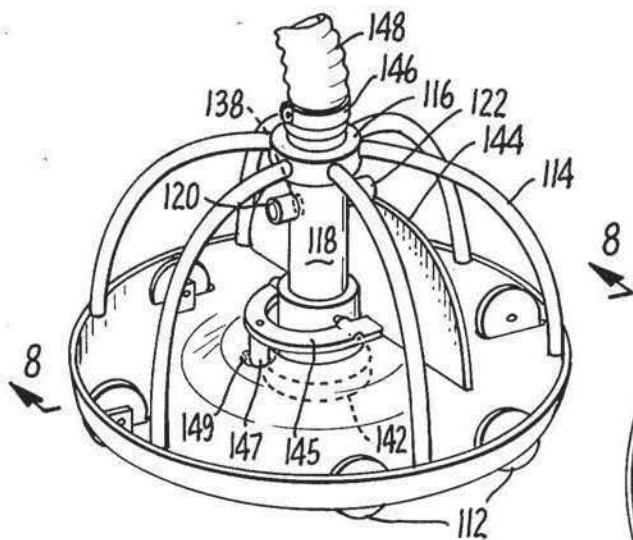


FIG. 7.

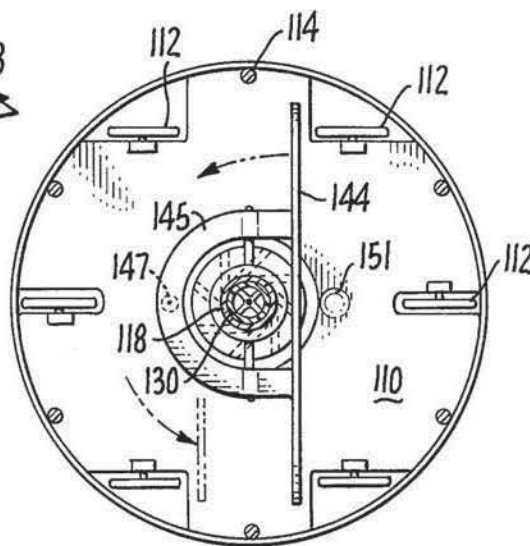


FIG. 9.

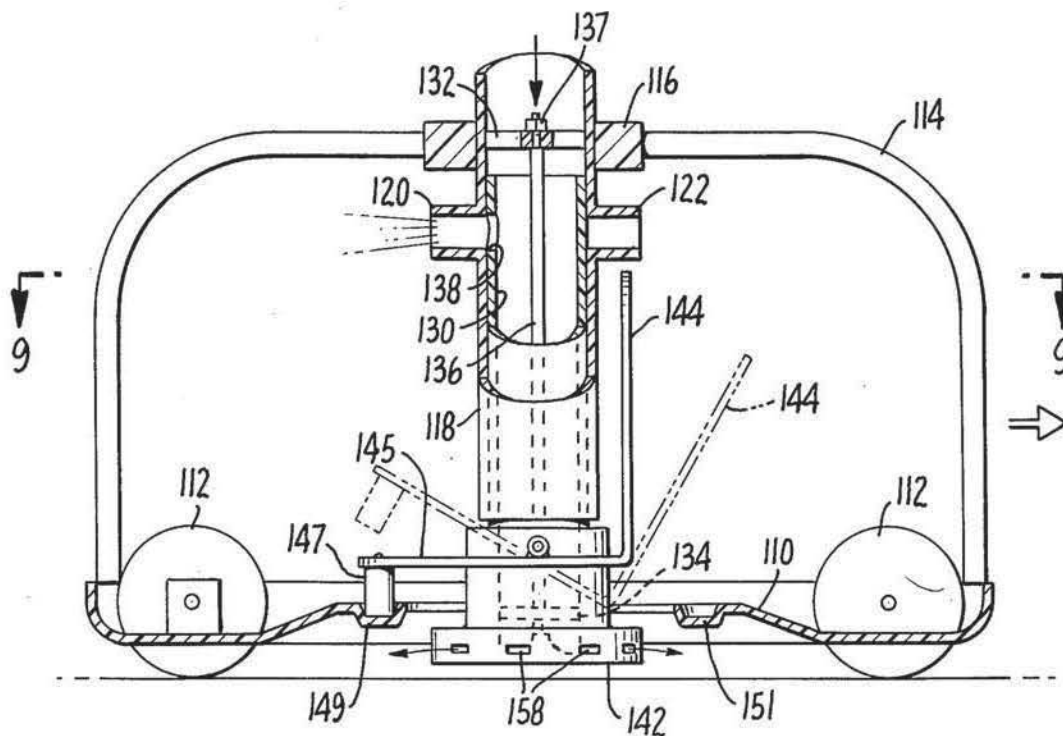


FIG. 8.

U.S. Patent

July 18, 1978 Sheet 4 of 9

4,100,641

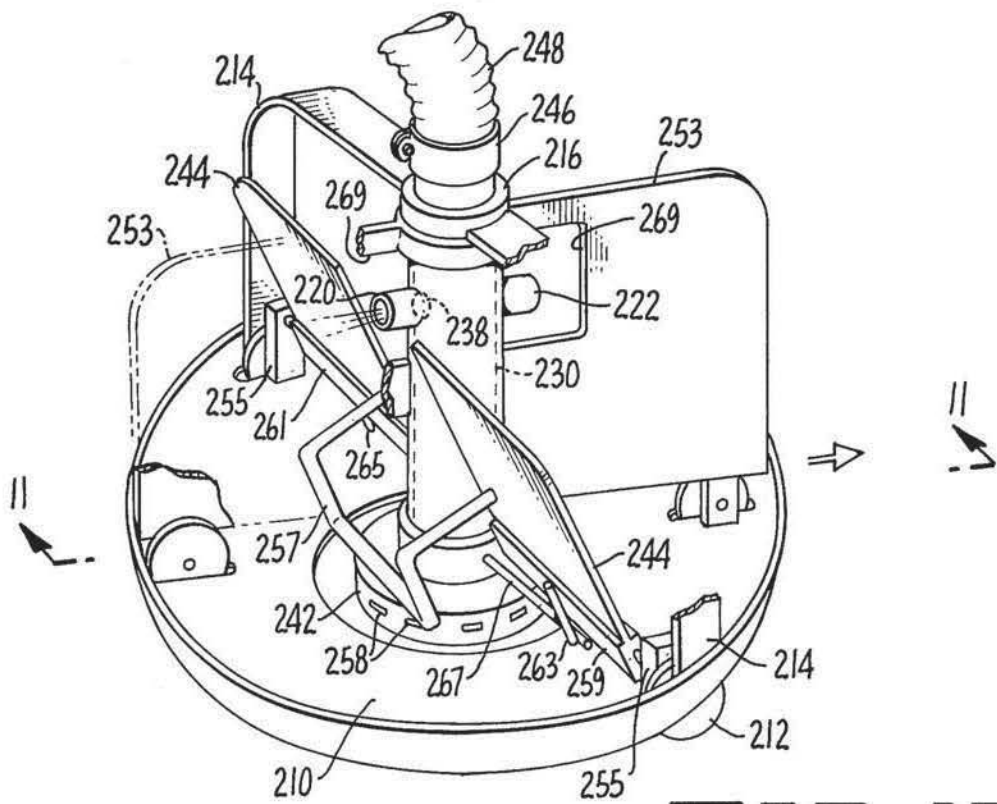


FIG. 10.

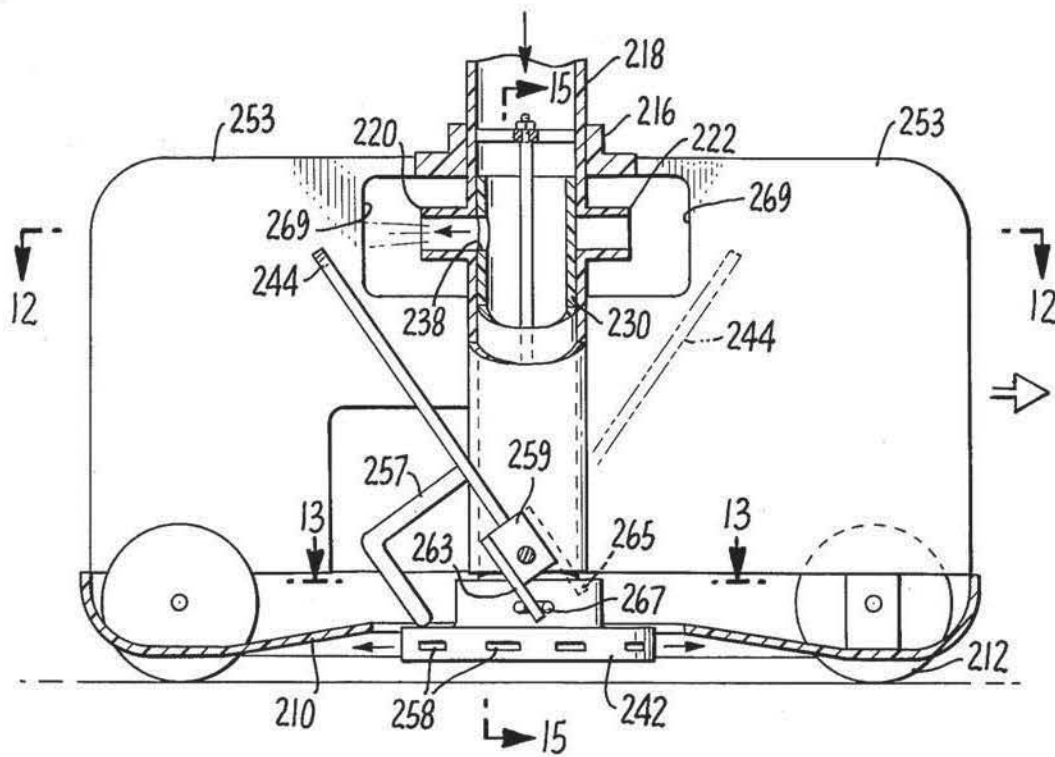


FIG. 11.

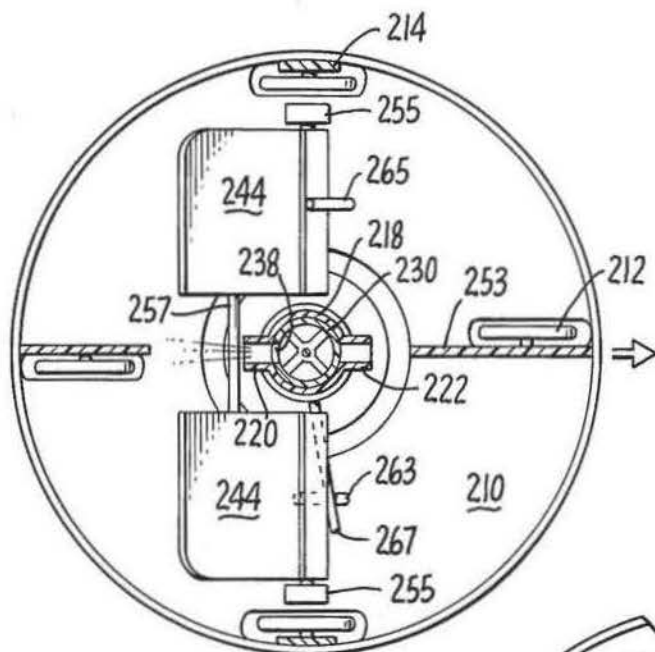


FIG. 12.

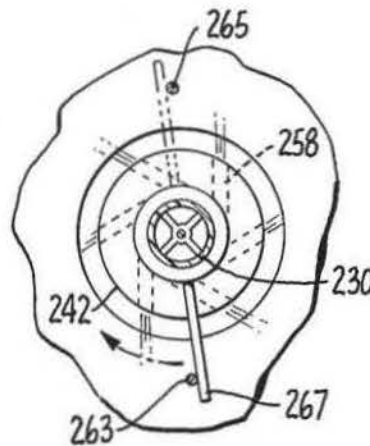


FIG. 13.

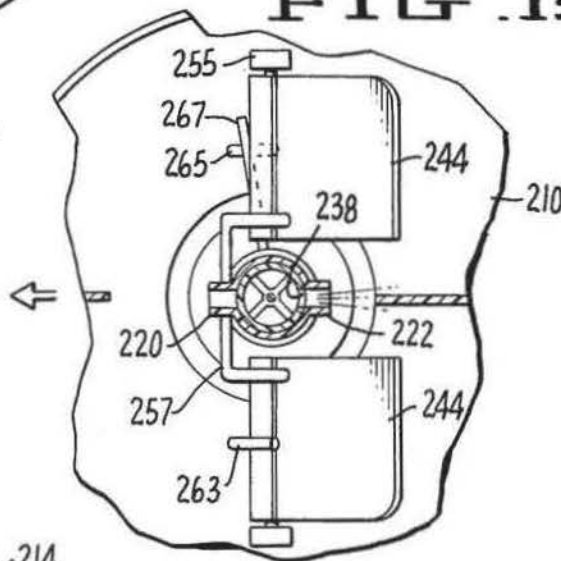


FIG. 14.

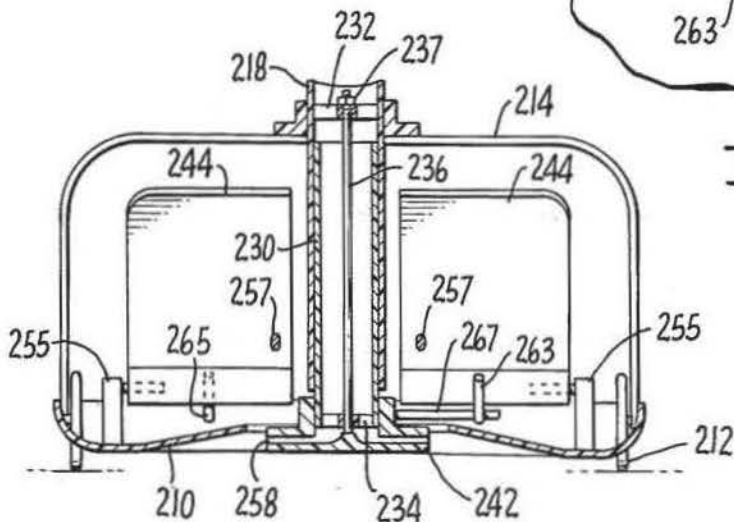


FIG. 15.

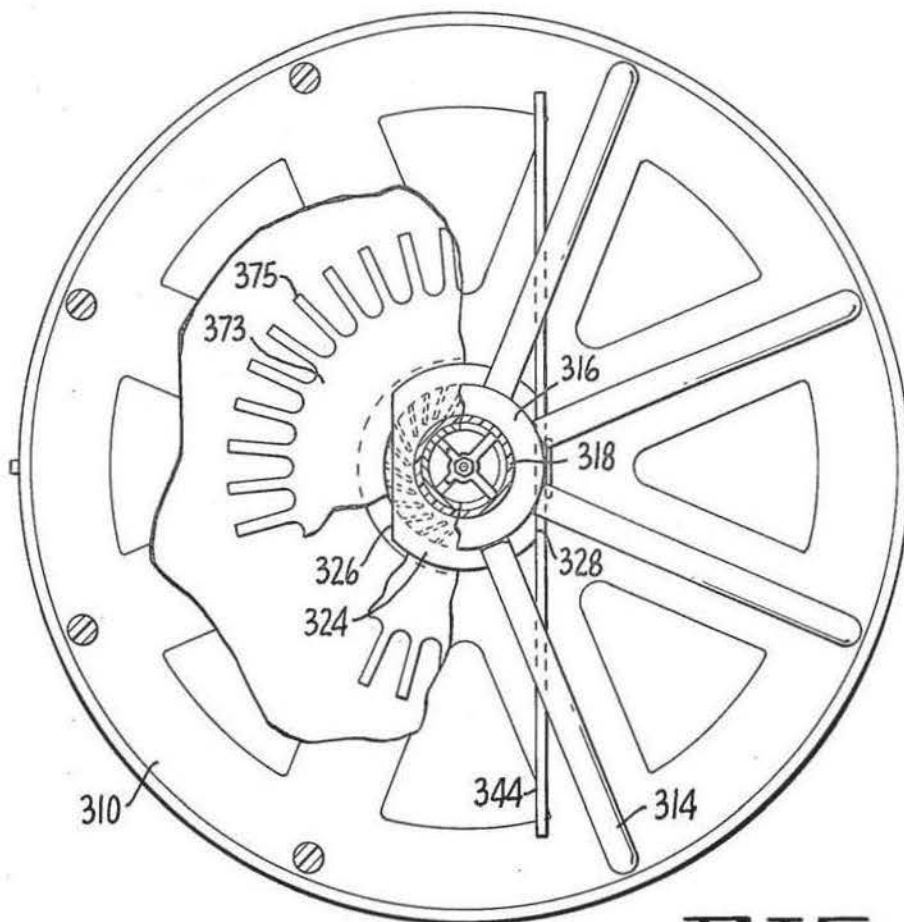


FIG. 17.

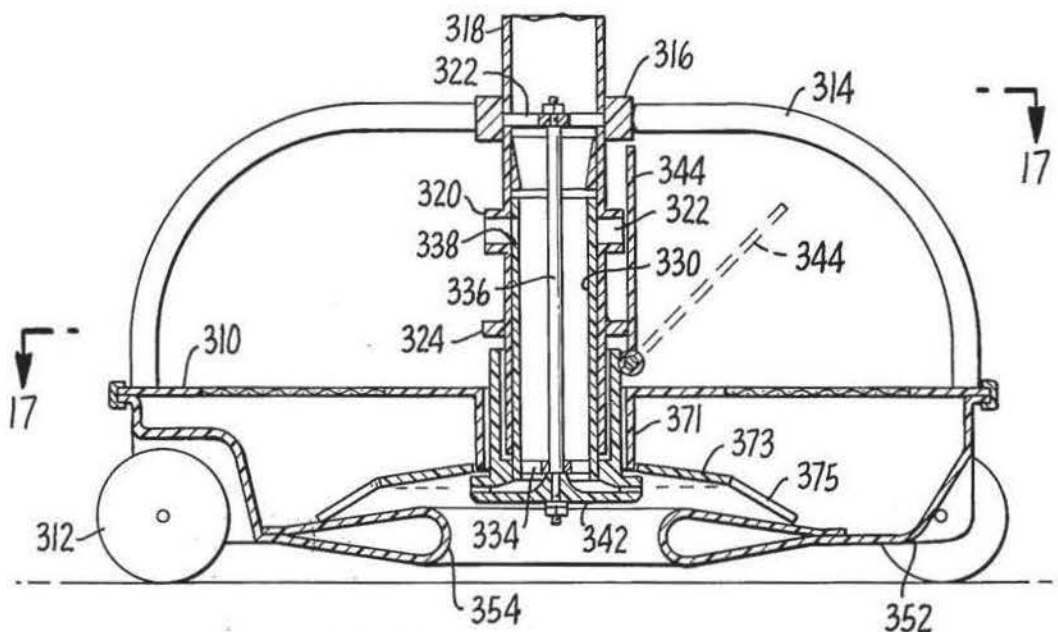


FIG. 16.

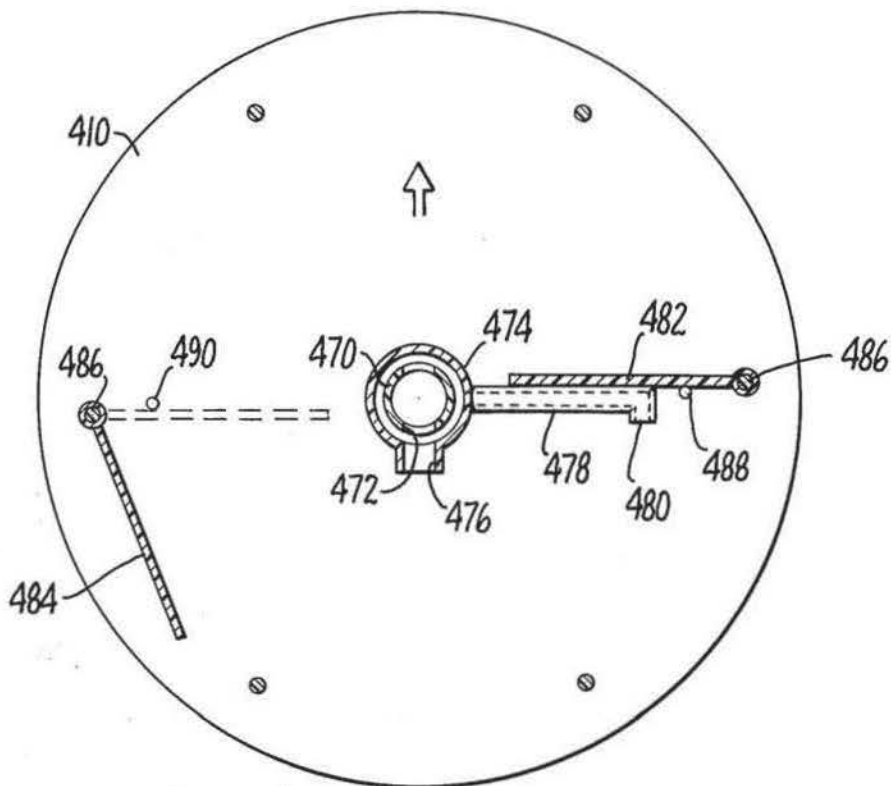


FIG. 19.

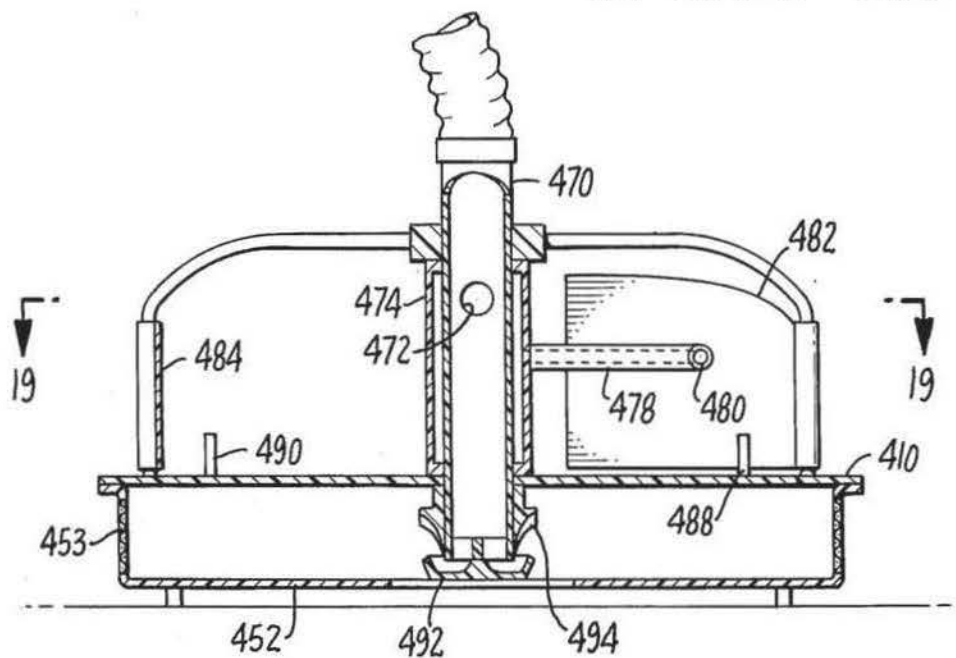


FIG. 18.

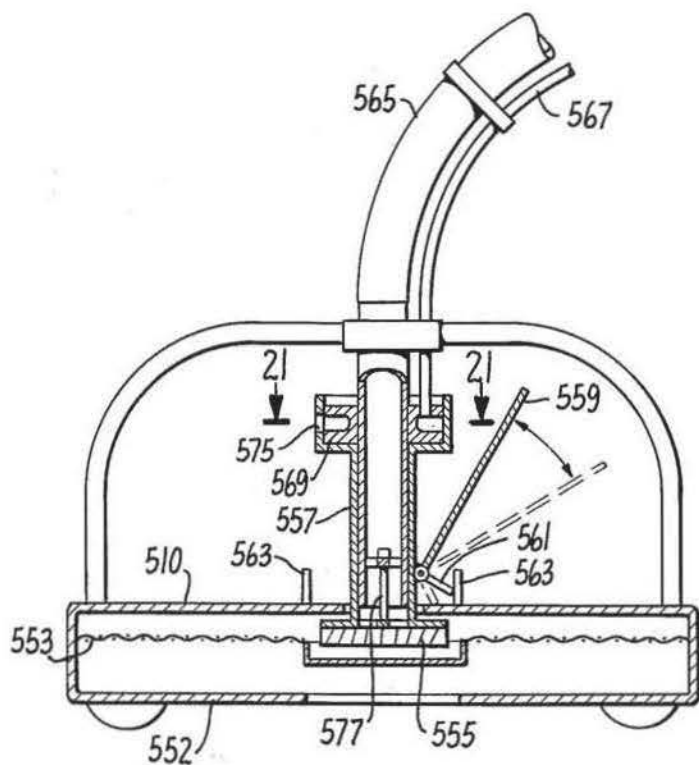


FIG. 20.

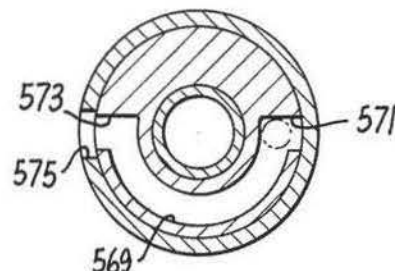


FIG. 21.

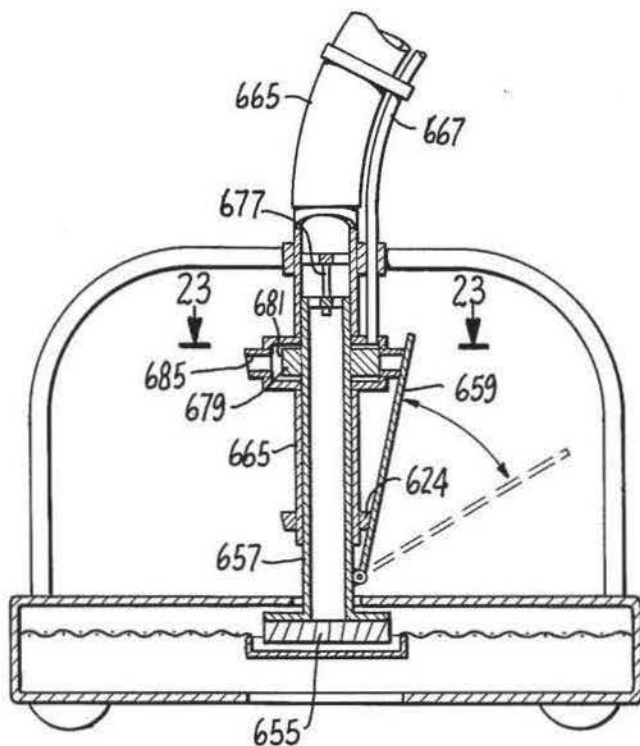


FIG. 22.

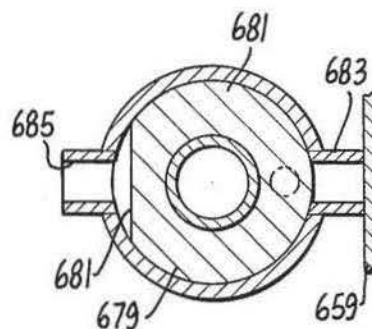


FIG. 23.

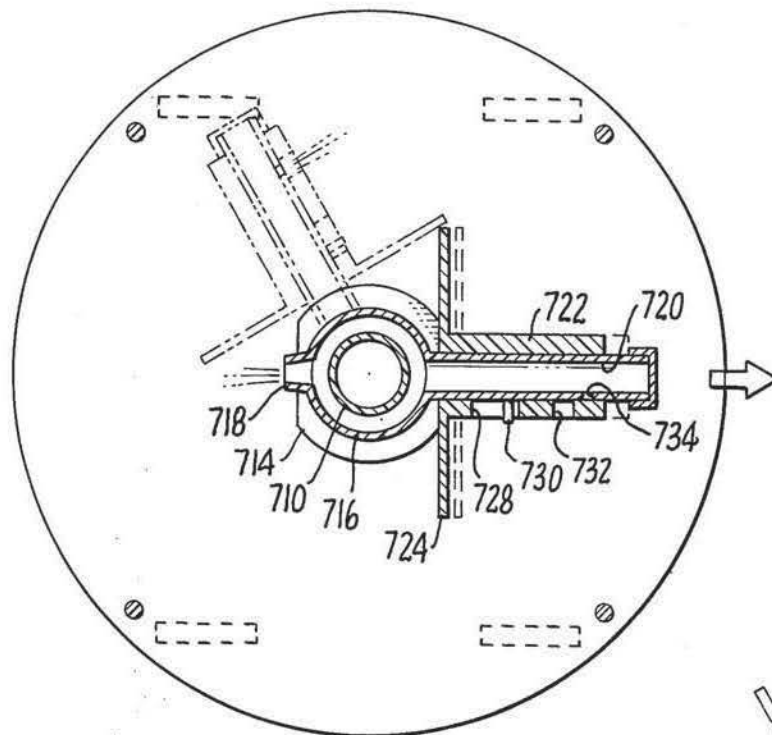


FIG. 24.

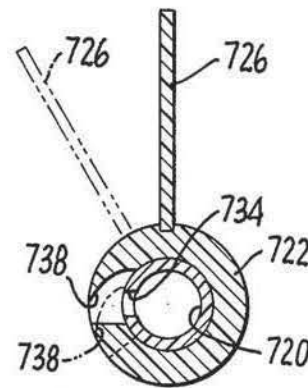


FIG. 26.

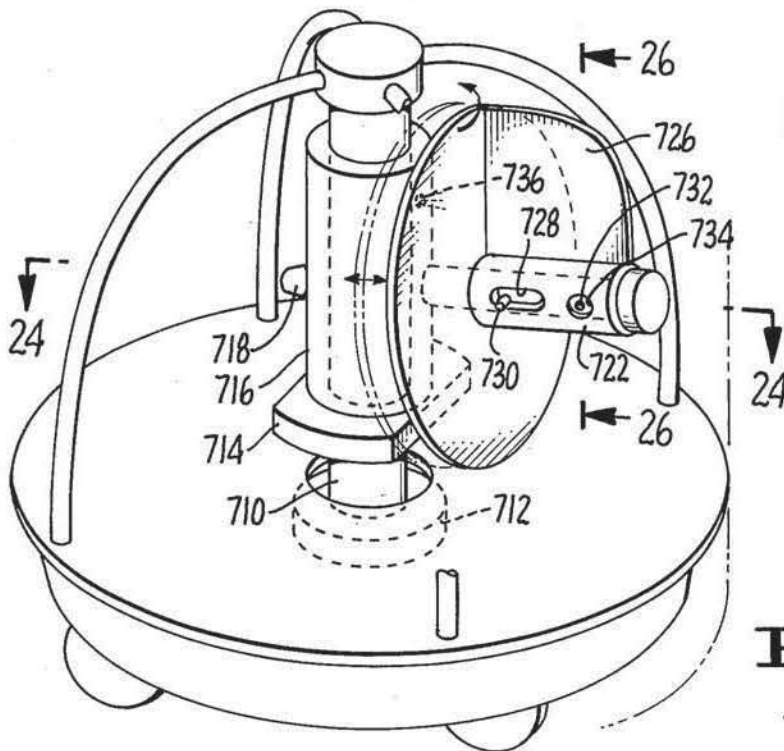


FIG. 25.



4,100,641

1

## SWIMMING POOL CLEANERS

## SUMMARY OF THE INVENTION

Cleaners embodying the present invention travel in a submerged condition along non-repetitive paths until in a given period of time they travel over the entirety of the submerged side wall and floor surfaces of the pool. They differ from the previously known cleaners of this type shown in U.S. Pat. Nos. 3,229,315 and 3,822,754 in that they do not have power driven wheels and instead have selectively operable oppositely directed drive jets which are turned on and off depending upon the ambient pressure forces applied to blade control elements as the cleaner moves through the water. The cleaner may utilize a flow of water issuing from it to cause the cleaner to be pressed against the pool wall surface as well as to rotate a control element to reverse the direction of jet drive when rotation of the control element is permitted by a decrease in the ambient pressure applied to a blade unit carried by the control element. The cleaner may also utilize a flow of water issuing from it to cause it to be pressed against the pool wall surface while employing other means, such as a separate flow of water issuing from a rotatable nozzle, to reverse the direction of jet drive when the ambient pressure permits such reversal.

An object of the invention is to provide a wheel-supported underwater automatic pool cleaner in which the wheels are not employed as traction means but are instead used as means to decrease the friction between the physical pool surfaces and the cleaner.

A further object of the invention is to provide a wheel-supported underwater automatic pool cleaner which is able to continuously move back and forth along varying paths to accomplish full pool cleaning coverage.

Still a further object of the invention is to provide an automatic pool cleaner of the underwater water-powered type as to which water from the pressure side of the pool's filter system is fed back into the pool through the cleaner and there is no need to employ a booster pump for proper operation of the cleaner.

Another object of the invention is to provide a pool cleaner of the type described in which the pressurized water delivered to the cleaner is divided into two parts, one part issuing through a jet nozzle disposed above the vehicle part of the cleaner to drive the cleaner and the other part issuing from the cleaner at the underside thereof to induce a suction force to both press the cleaner against the pool wall surface and induce leaves and other debris to be drawn into a collecting chamber provided in the cleaner.

Other objects and advantages of the invention will be apparent from the following description taken in conjunction with the drawings forming part of this specification, and in which:

FIG. 1 is a view in perspective of one embodiment of the cleaner of the invention;

FIG. 2 is a detail view in perspective of the drive system of the FIG. 1 cleaner and the control means for the drive system;

FIG. 3 is an enlarged view in section taken along a vertical diametral plane of the FIG. 1 cleaner;

FIG. 4 is a detail view taken along lines 4—4 of FIG. 3;

FIG. 5 is a detail view taken along lines 5—5 of FIG. 3;

2

FIG. 6 is a view like FIG. 4 but showing the pressure-responsive control blade in a solid line condition of operation and in a dotted line condition of operation;

FIG. 7 is a view in perspective of another embodiment of the cleaner of the invention;

FIG. 8 is an enlarged view taken along lines 8—8 of FIG. 7;

FIG. 9 is a view reduced in size taken along lines 9—9 of FIG. 8;

FIG. 10 is a view in perspective of a further embodiment of the cleaner of the invention;

FIG. 11 is an enlarged view taken along lines 11—11 of FIG. 10;

FIG. 12 is a view reduced in size taken along lines 12—12 of FIG. 11;

FIG. 13 is a view reduced in size taken along lines 13—13 of FIG. 11;

FIG. 14 is a view like FIG. 12 but showing the direction of movement of the cleaner as being to the left rather than to the right;

FIG. 15 is a view reduced in size taken along lines 15—15 of FIG. 11;

FIG. 16 is a view in diametral section of a further embodiment of the invention;

FIG. 17 is a view taken along lines 17—17 of FIG. 16;

FIG. 18 is a view of another embodiment of the invention;

FIG. 19 is a view taken along lines 19—19 of FIG. 18;

FIG. 20 is a view of another embodiment of the invention;

FIG. 21 is a view taken along lines 21—21 of FIG. 20;

FIG. 22 is a view of another embodiment of the invention

FIG. 23 is a view taken along lines 23—23 of FIG. 22;

FIG. 24 is a view taken along lines 24—24 of FIG. 25 of another embodiment of the invention;

FIG. 25 is a view in perspective of the cleaner of FIG. 24; and

FIG. 26 is an enlarged detail view taken along lines 26—26 of FIG. 25.

Referring first to FIGS. 1-6 of a preferred embodiment of the invention, the cleaner comprises a plate or platform member 10 supported by wheels 12 and in turn supporting bar members 14, collar 16 and fixed tube 18. Tube 18 is provided with oppositely and somewhat upwardly directed jet nozzle tubes 20 and 22. Fixedly attached to tube 18 is a ring member 24 having opposed flat surfaces 26 and 28. An inner tube 30 is rotatably supported within the fixed tube 18 by a novel swivel interconnection comprising cruciform-shaped web 32 fixedly attached to tube 18, cruciform-shaped web 34 fixedly attached to the inner tube 30 at the lower end thereof, a hanger rod 36, and lock nuts 37 attached to the ends of rod 36 and loosely connecting the rod 36 to each of the webs 32 and 34. The tube 30 is provided with a port 38 which is selectively registrable with the inner ends of each of the jet nozzle tubes 20 and 22.

Fixedly attached to the inner tube 30 is a water flow reversing member 40, a reaction impeller 42, and a pivotally supported pressure responsive blade element 44.

Attached to the upper end of the fixed tube 18, as by a clamping ring 46 is a flexible, floatable hose 48 which extends up to the surface, floats on the surface, and is capable of receiving the entire pressurized water output of the pool's filter system. Although not shown in the drawings, hose 48 is made up of a plurality of swivel-connected sections, the swivel connections being similar to the swivel connection system 32, 34, 36, 37. Re-

4,100,641

3

movably attached, as by means including a catch 50, to the underside of the plate 10 is a tray member 52 defining with the plate 10 a filtration compartment or receptacle for leaves and debris, the underside of the tray 52 being provided with a central inlet flow aperture 54. The plate 10 and the side wall of the tray 52 are provided with water flow passageways 56.

The operation of the embodiment of FIGS. 1-6 is as follows. As shown in FIG. 3, the left hand jet nozzle 20 is in operation and the cleaner is moving to the right. Part of the water coming down the tube 18 passes out the drive nozzle 20 and the rest of the water flows out the lower end of the tube 30, is reversed in direction by deflector members 40, traverses spiral grooves 58 (see FIG. 5) of the impeller 42, thereby tending to turn the impeller 42 in a counter-clockwise direction (FIG. 5), and issues substantially horizontally into the leaf compartment defined by plate 10 and tray 52. This flow in turn induces a horizontal suction flow of water beneath the cleaner which creates a low pressure area beneath the cleaner, thereby serving to press the cleaner against the pool wall surface 60. The suction flow beneath the cleaner also removes fine dirt from the pool wall surface and causes the leaves and other larger debris to move into the storage compartment above the tray 52.

As the cleaner moves with normal speed to the right (FIG. 3) the ambient water pressure applied to blade element 44 presses the blade against the flat surface 28 of ring member 24, thereby locking the impeller and tube 30 against rotation. When the cleaner slows down or stops, the impeller begins to rotate, causing the blade element 44 to move away from ring member 24 to the dotted line position where it is free of the blocking ring 24. The impeller 42 continues to rotate in a counter-clockwise direction until the blade element 44 has rotated through 180° (see FIG. 6). This aligns the jet orifice 38 with the jet nozzle 22 and causes the cleaner to be driven to the left (FIG. 3), thereby causing the ambient water pressure to press the blade element 44 against the flat surface 26 of ring member 24 and lock the impeller and the inner tube against further rotation. The cleaner proceeds in the particular direction in which it is going until it again comes to a stop or slows appreciably. The consequent reversal of the jet drive then drives the cleaner off in the generally opposite direction. The cleaner is prevented from moving back and forth along the identical path by a large number of variable resistance forces which the cleaner encounters, as for example the slope and shape of the pool wall surface it is travelling along, the resistance under certain conditions and in certain positions of the flexible inlet hose 48, etc. Due to such variant forces the cleaner is able to traverse the entirety of the submerged pool wall surfaces, including the side walls of the pool up to the water line.

The force holding the cleaner against the pool floor or side wall of the pool as a result of the suction flow beneath the cleaner induced by the water flow from the impeller 42 enables the cleaner to climb the side walls of the pool. When it does so and the blade element 44 reaches the surface of the pool water the resistance to rotative movement of the impeller 42 and the inner tube 30 is decreased to the point where these elements rotate to reverse the jet nozzle drive system. The described hold-down force is augmented by the angular disposition of the jet nozzles 20 and 22, i.e. each of the drive

4

jets furnishes an additional component of hold-down force to the cleaner.

The embodiment of the invention shown in FIGS. 7-9 is somewhat simpler than the FIG. 1-6 embodiment. Parts essentially corresponding to those described for the FIG. 1-6 embodiment are identified by corresponding reference numerals plus 100. The plate or platform 110 is provided with wheels 112, bars 114, collar 116, fixed tube 118 having opposed jet nozzles 120 and 122 extending normal thereto, inner tube 130 having swivel support mounting system 132, 134, 136 and 137 and provided with jet nozzle outlet port 138, an outlet impeller 142 secured to the inner tube 130 and having non-radial outlet passageways 158 adapted to rotate the impeller and the inner tube in a counterclockwise direction (FIG. 9), blade element 144 having a yoke attachment 145 which is pivotally connected to the inner tube 130, and a stop member 147 carried by the yoke 145 and adapted to be alternatively received within sockets 149 and 151 formed in plate 110.

The FIG. 7-9 embodiment operates as follows. In FIG. 8 the cleaner is moving to the right. The ambient water pressure is holding the blade element 144 in the upright solid line position, thereby pressing the locking or detent element 147 into socket 149 and preventing rotation of impeller 142 and inner tube 130. The water issuing from the impeller outlets 158 flushes the dirt off of the adjacent pool wall surface over a substantial circular area, and this high velocity outlet water also sets up a low pressure condition beneath the cleaner which results in a strong hydraulic hold-down force being applied to the cleaner, enabling it to climb the pool side walls as previously described. When the cleaner slows sufficiently or stops, the ambient pressure against blade element 144 is substantially decreased, enabling the blade element 144 to move to the dotted line position of FIG. 8 to thereby move the detent 147 out of socket 149. The impeller 142 and inner tube 130 consequently rotate through 180° and as the port 138 gets into registry with the jet drive nozzle 122 the cleaner moves forwardly in the opposite direction and the ambient pressure moves the blade element 144 to an upright position to lock detent 147 in socket 151.

The embodiment of FIGS. 10-15 is quite similar to that of FIGS. 7-9, differing therefrom in the specific details of the blade element restraint system for the impeller 242 and the inner tube 230 and in the provision of a fixed stabilizer fin 253 disposed in the plane of the normal direction of travel of the cleaner. Parts corresponding to those of FIG. 1-6 are identified by the same reference numerals plus 200.

In the FIG. 10-15 embodiment there are two blade elements 244. They do not rotate about the central tubes as in the previously described embodiments, but instead flop or pivot back and forth. The blade elements are pivotally attached to posts 255 carried by the plate or platform 210 and are interconnected by a yoke member 257. The stabilizer fin is provided with a suitable relief slot, not shown, to accommodate the yoke 257 as the blade elements 244 move between the solid line and dotted line extremes of FIG. 11. The blade elements are attached to bar elements 259 and 261. Attached to one side of bar element 259 is a stop rod 263 (FIG. 11) and attached to the opposite side of the bar element 261 for the other blade element is another and similar stop rod element 265. Connected to the impeller and inner tube assembly is a radially extending rod 267.

4,100,641

5

The operation of the FIG. 10-15 embodiment is as follows. In FIG. 11 the cleaner is in normal movement to the right. Both blade elements 244 are in the solid line position, being supported in that position by engagement between the yoke 257 and the impeller 242. The water issuing from impeller 242 tends to rotate the stop rod 263 is disposed in blocking relation to the radial rod 267, the ambient water pressure exerted against the two blade elements 244 being sufficient to keep the stop rod 263 in its blocking position. When the cleaner slows or stops, the drop in the ambient water pressure acting on the blade elements 244 decreases to the point where the rotative force applied to stop rod 263 by rod 267 swings the blade elements to the dotted line position of FIG. 11, enabling rod 267 to move past rod 263 but placing rod 265 in blocking relation to the rod 267, the latter condition being maintained by the ambient water pressure being applied to the blade elements in their new position by consequent movement of the cleaner toward the left, with reference to FIG. 11. The yoke 257 engages tube 218 to prevent the blade elements from moving further to the right past the dotted line position of FIG. 11.

The stabilizer fin 253 is provided with openings 269 to accommodate the drive jet nozzles. The water jet issuing from the active drive jet nozzle is divided by the stabilizer fin so as to pass half to one side of the fin and half to the other. The combination of the ambient water pressure and the division of the water jet driving the cleaner together make for an effective stabilizer force tending to cause the cleaner to move back and forth in the plane of the stabilizer fin 253. Other forces acting on the cleaner, such as its movement over curved or slanted surfaces, as well as the somewhat restrictive tethering force applied to the cleaner by the floatable hose 248, cause the cleaner to deviate from merely a back and forth movement along the same path so that over a period of a few hours the entirety of the pool floor and side wall surfaces is traversed and cleaned by the cleaner.

The FIG. 16-17 embodiment is quite similar to the FIG. 1-6 embodiment. Corresponding parts are identified by corresponding reference numerals plus 300.

The FIG. 16-17 embodiment differs from the FIG. 1-6 embodiment in that the total water in the inner tube 330 issues horizontally therefrom, i.e. both from the immediately active drive nozzle 320 or 322 and from the impeller 342. The water issuing from tube 330 therefore does not exert a downward thrust on the cleaner. Also, the plate 310 is provided with a central hub 371 which serves to center a free floating disc 373. The disc is provided with a slotted or combed edge 375. The disc 373 prevents the suction jets of the impeller 342 from drawing water downwardly within the leaf and debris storage compartment, thus increasing the suction lift applied beneath the cleaner by the impeller jets. The combed edge serves to prevent leaves within the storage compartment from being lost from this compartment in the midst of removing the cleaner from the pool to empty the leaf tray. The cleaner otherwise operates the same as that of FIGS. 1-6.

It will be appreciated that a swivel system corresponding to the swivel system 32, 34, 36, 37 is employed in all of the above-described embodiments of the invention. This swivel system plays an important part when the form of the subject invention includes inner and outer concentric tubes 18 and 30 which rotate relative

6

to each other. The swivel system minimizes frictional resistance to such relative rotative movement. There is little or no frictional engagement between the outer surface of inner tube 30 and the inner surface of the outer tube 18 due to the undersized outer diameter of tube 30. To insure that dirt particles in the inlet water, which is at a pressure of about 20-30 psi gauge, from the pressure side of the pool filter system does not enter into the clearance space between the two tubes, a tapered ring 37 (FIG. 3) is secured within the tube 18, as well as in all of the embodiments shown in the drawings, to direct the inlet flow into the interior of the inner tube 30. Substantially the only frictional drag between the two tubes 18 and 30, that is, resistance to rotative movement of the inner tube 30 within the outer tube 18 takes place at the loose connection joint between the rod 36 and the web 32. The consequent frictional drag is immaterial insofar as constituting an abstacle to turning movement of the inner tube.

It will also be appreciated that the supply hose is towed or pulled by the wheeled carrier or transporter, and that thus the supply hose tends to tip the transporter over in the various embodiments described. The drive jets from the nozzles 20-22, 120-122, 220-222, 320-322, being located above the center of gravity of the transporter and tending to tip the transporter in the opposite direction, offset the tipping force applied by the supply hose.

It will be appreciated that the drive nozzle means for the carrier may be single and rotatable rather than double and alternately off and on. For example, a rotatable tube on the carrier could carry the blade element, the blade element-turning impeller and a single drive nozzle. When the carrier slowed or stopped, the impeller would rotate the rotatable tube while the nozzle continued to issue its drive jet. However the jet would not become drivingly effective until it becomes turned sufficiently to drive the carrier off in another direction on the carrier wheels.

The FIG. 18-19 cleaner embodiment comprises a wheeled carrier comprising plate 410, leaf compartment lower wall 452, perforate leaf compartment side wall 453, a single fixed water supply tube 470 having a pair of opposed ports 472, a sleeve 474 supported for rotation on tube 470, a port 476 in the sleeve 474 selectively registrable with the ports 472, a water conduit arm 478 carried by sleeve 474 and terminating in a jet nozzle 480 which is disposed at a right angle, or substantially so, to arm 478, blade elements 482 and 484 pivotally attached to supports 486, blade stop members 488 and 490, a water-reversing deflector 492 attached to the lower end of tube 470, and annular deflector 494.

The FIG. 18-19 embodiment operates as follows. As shown in FIG. 18, the cleaner would be travelling at a right angle to the paper and away from the viewer under the influence of jet 472, 476 and the jet from nozzle 480. The ambient water pressure forces the blade 482 against its associated blade stop 488. The other blade 484 assumes a neutral trailing position as shown in FIG. 19. The cleaner travels essentially straight ahead (FIG. 19), the blade 482 tending to cause it to veer to the right but the combined jet action of the two jets serving to offset that tendency. When the cleaner slows or stops, the arm 478 rotates under the influence of the jet from nozzle 480, swinging the blade 482 to the dotted line position in FIG. 19. Rotation of the arm 478 to an amount approaching 180° aligns the sleeve port 476 with the other jet port in tube 470, whereupon the

4,100,641

7

cleaner starts to move in a reverse direction and the ambient water pressure forces the blade 484 to the dotted line position in FIG. 19 where it bears against its associated stop member 490 to block further rotative movement for the time being of arm 478. Meanwhile, beneath the plate 410 the operation remains simple and unchanging, i.e. the balance of the water in tube 470 issues from the lower end of tube 470, is directed upwardly by the deflector member 490, and is directed horizontally into the leaf compartment by the deflector 494. This flow of water from tube 470 into the leaf compartment induces a suction flow of water along the pool wall surface beneath the cleaner, with the result that leaves and other debris are carried into the leaf compartment and the cleaner is pressed against the pool wall surface.

The FIG. 20-21 cleaner embodiment comprises a wheeled carrier comprising plate 510, leaf compartment lower wall 552, perforate leaf compartment upper wall 553, an impeller 555 fixedly attached to a rotatable tube 557, a blade 559 carried by and pivotally connected to the rotatable tube 557, a flange 561 on the blade 559, stop elements 563 to be engaged by the flange 561 and lock the tube 557 against rotation during normal movement of the cleaner, a suction tube 565, a pressure tube 567, a fixed manifold 569 having opposed jet openings 571, 573, an aperture 575 formed in the upper enlarged part of tube 557 and adapted to be selectively aligned with the jets 571, 573, and a swivel connection 577 of the type previously described interconnecting the suction tube 565 with the impeller portion 555 of tube 557 for the rotational support of the latter.

The operation of the FIG. 20-21 embodiment is as follows. Pressurized water passes through the tubes 567 to the manifold 569 and out of the jet opening 571, 573 which is aligned with the orifice 575. In FIG. 20, the cleaner is proceeding toward the right and the ambient water pressure forces the blade flange 561 against the right hand stop 563 to prevent rotation of the tube 557. Pressure tube 567 may be connected to the outlet of a filter pump while suction tube 565 may be connected to the inlet side thereof. Water flows up through the central opening in the leaf compartment lower wall 552, through the impeller 555 tending to rotate the same, and into the suction tube. When the cleaner slows down in its movement to the right, the tube 557 is rotated under the action of water flowing through the impeller 555 into the suction tube 565 and the blade is rotated around into association with the left hand stop 563, whereupon the tube aperture 575 becomes aligned with the jet 571 and the cleaner commences movement to the left.

The FIG. 22-23 embodiment, like the preceding one, uses a suction tube to turn the jet-controlling blade. It comprises a suction tube 665, a pressure tube 667, an impeller 655 fixedly attached to a tube 657 which is carried for rotation within the lower end of the tube 665 by the above-described swivel connection 677, a disc 679 fixedly attached to tube 657 and having a flat 681 enabling the selective connection of the jets 683, 685 to the pressure tube 667, a blade 659 carried by and having a pivotal connection with the tube 657, and a ring member 624 carried by tube 665 and adapted, like the ring member 24 of FIG. 1, to control the position of blade 659.

The operation of the FIG. 22-23 embodiment is as follows. The cleaner is moving to the right in FIG. 22, the flat 681 being disposed adjacent the left jet 685. As the cleaner slows down, suction-induced flow through

8

the impeller 655 rotates the tube 657 to render jet 685 inoperative and jet 681 operative.

It will be appreciated that the embodiments of FIGS. 20-23 are well adapted for use in pools which do not have main drains. The pressurized water for the pressure tube 667 can either be obtained from a booster pump in the pool filter system or merely by tapping into the pool filter system at the discharge side of the filter pump.

The FIG. 24-26 embodiment comprises a fixed central tube 710, to the upper end of which the water supply hose, not shown, is attached, having a water deflector 712 at the lower end thereof. Attached to tube 710 is a cam ring 714. Sleeve 716 carrying a jet outlet 718 and arm 720 is mounted for rotation about tube 710. A sleeve 722 is slidably mounted on arm 720 and the sleeve carries an annular disc 724. The sleeve 722 is provided with a vertical fin 726. The sleeve is also provided with a relief slot 728 for a pin 730 carried by arm 720. The sleeve is also provided with an aperture 734 through which a rotation drive jet 732 for the arm 720 may operate.

The operation of the FIGS. 24-26 embodiment is as follows. The cleaner is set up to move to the right in FIG. 24. Water from within the fixed tube 710 flows into the space between said tube and sleeve 716 through port means, not shown, and the drive jet issuing from jet nozzle 718 moves the cleaner to the right. Ambient water pressure forces the disc 724 against the adjacent flat of the cam ring 714. Jet 732 is closed by the overlying sleeve 722, and consequently no turning force is being applied to the flow direction control sleeve 716. Sleeve 716 is provided with a jet opening 736 through which there issues a jet tending to push the disc 724 to the right. Instead of the jet 736, a spring could be provided to urge the disc 724 to the right. As the cleaner slows or stops, the jet 736 drives the disc to the right to thereby open the rotation jet 732 and drive the arm 720 and the attached sleeve 716 in a counter-clockwise direction (FIG. 24) until the disc comes into parallelism with the left hand flat of cam ring 714, whereupon the nozzle 718 is lined up with the plane of rotation of the wheels and the cleaner commences movement toward the left, the ambient pressure forcing the disc against the cam ring flat to close off the rotation jet 732. On its travel around the outer edge of the cam ring 714, disc 724 and its associated sleeve 722 hold aperture 734 in alignment with rotation jet 732 until the drive jet 718 finds the plane of the wheel alignment. During the course of this 180° movement of the rotatable assembly, the jet 732 is intermittently opened and closed. This enables the usage of a strong jet 732 but slows down the time for the 180° movement so that the time required for it is a few seconds or so. This intermittent operation of jet 732 is accomplished by the vertical fin 726 and a cam surface 738 (FIG. 26) formed in sleeve 722 adjacent aperture 734. As the arm 720 rotates the ambient water pressure moves the fin from the solid line to the dotted line condition of FIG. 26, i.e. due to the degree of over-size between slot 728 and pin 730, to block the jet opening 732. The jet from opening 732 then works against the cam-like surface 738 to drive the sleeve 722 in a clockwise direction (FIG. 26) thereby unblocking the jet 732 and returning the fin 726 to a vertical position. Such repetitive blocking and unblocking of jet 732 takes place during the 180° movement of the rotatable assembly.

4,100,641

9

It will be appreciated that various modifications and ramifications of the foregoing embodiments may be made without departing from the present invention. For example the outer tube may be fixed but made in two vertically spaced sections, the upper section carrying the opposed jet nozzles and the lower section extending, in effect, through the top plate of the carrier into the leaf compartment and terminating in an annular nozzle discharging radially into the leaf compartment, while the rotatable inner tube has a portion between the upper and lower outer tube sections which is exposed and carries a blade of the FIGS. 7-9 type and also carries a rotation arm with jet, as in FIGS. 18-19. Various other combinations of the operating parts of the above-described embodiments will be apparent from the foregoing to those skilled in the art.

What is claimed is:

1. An automatic pool cleaner comprising a wheel-supported carrier, a plurality of concentric tubes extending upwardly from the carrier and comprising an outer tube fixedly attached to the carrier and an inner tube carried for rotation within the outer tube, a plurality of drive jet nozzles directed laterally from the outer tube, a port formed in the inner tube adapted to be selectively moved into and out of communication with the respective drive jet nozzles by rotative movement of the inner tube, a water supply conduit in delivery relation with the inner tube, a nozzle carried by the lower end of the inner tube operable upon the discharge of water therefrom to apply a rotative force to the inner tube, means responsive to a predetermined upper ambient pressure range resulting from movement of the carrier through the pool water to prevent rotation of the inner tube and responsive to a predetermined lower ambient pressure range to permit such rotation of the inner tube and thereby move said port out of communication with one of said drive jet nozzles and into communication with another one of said drive jet nozzles, thereby effecting a change in the direction of movement of said carrier and generally re-establishing said predetermined upper ambient pressure range to act through said means and prevent further rotation of the inner tube.

2. The cleaner of claim 1, said nozzle having an annular pattern of off-center outlets operable to discharge water into a leaf and debris storage compartment defined in said carrier and thereby induce a suction flow of pool water beneath said carrier inwardly to an annular inlet for said compartment, said suction flow being effective to remove dirt from the pool wall surfaces contacted thereby.

3. The cleaner of claim 1, said nozzle having an annular pattern of off-center outlets operable to discharge water outwardly beneath said carrier to remove dirt from the pool wall surfaces contacted thereby.

4. An automatic pool cleaner comprising a wheel-supported carrier, a water supply conduit, tube means mounted on the carrier for receiving water from said conduit, drive jet nozzle means associated with said tube means to receive water from the latter and drive said carrier, means for controlling the direction of flow of water from said nozzle means to thereby control the direction of movement of said carrier, and means responsive to the ambient pressure condition of said pool water to control said means for controlling the direction of flow of water from said nozzle means.

5. An automatic pool cleaner comprising a wheel-supported carrier, a water supply conduit, a plurality of nozzle means carried by said carrier in communication

10

with said conduit and selectively operable by the unblocking of one and the blocking of another of said nozzle means to drive said carrier in a plurality of different directions, means responsive to deceleration in the movement of said carrier in a given direction to block one nozzle means and to unblock another nozzle means to drive said carrier in a different direction, and means to continue driving said carrier in said different direction until its movement therealong is decelerated.

6. An automatic pool cleaner comprising a wheel-supported carrier, a water supply conduit, drive nozzle means carried by said carrier, means to connect and disconnect said nozzle means with respect to said conduit, said latter means including means responsive to deceleration in the movement of said carrier to disconnect said nozzle means from said conduit.

7. An automatic pool cleaner comprising a wheel-supported carrier, a water supply conduit, drive nozzle means rotatably carried by said carrier to selectively direct the movement of said carrier by the selective connection thereof to said conduit, and means responsive to deceleration in the movement of said carrier to rotate said nozzle means to a selected new position.

8. The cleaner of claim 7, including means responsive to the rotation of said nozzle means to said selected new position and to ambient pressure resulting from consequent movement of said carrier to lock said nozzle means in said new position.

9. An automatic pool cleaner comprising a wheel-supported carrier, a water supply conduit, a plurality of jet drive nozzle means carried by said carrier, control means for said drive nozzle means to cause said carrier to be impelled selectively in a plurality of directions by the selective connection of said drive nozzle means to said conduit, said control means including means responsive to deceleration in the movement of said carrier.

10. An automatic pool cleaner comprising a wheel-supported carrier, a pair of jet drive nozzles operative to drive said carrier in different directions by the selective connection and disconnection thereof with respect to a source of water under pressure, first means operative to disconnect one of said nozzles and to connect the other with respect to said source, and second means responsive to deceleration in the movement of said carrier to operate said first means.

11. An automatic pool cleaner comprising a carrier adapted to travel along a submerged surface of a pool, a pair of jet drive nozzles each operative to drive said carrier in a different direction, a source of water under pressure, first means operative to connect one of said nozzles to said source and disconnect the other therefrom, and second means including means connected to said source to operate said first means.

12. An automatic pool cleaner comprising a carrier adapted to travel along a submerged surface of a pool, a jet drive nozzle operative to drive said carrier in a given direction, a source of water under pressure, first means operative to connect and disconnect said nozzle with respect to said source, second means including means connected to said source to operate said first means, and carrier drive means operative a predetermined time after the operation of said first means by said second means and the consequent disconnection of said nozzle with said source to drive said carrier in another direction.

13. An automatic pool cleaner comprising a carrier adapted to travel along a submerged surface of a pool,

4,100,641

11

a pair of jet drive nozzles each operative to drive said carrier in a different direction, a source of water under pressure, first means operative to connect one of said nozzles to said source and disconnect the other therefrom, second means comprising a rotatable jet nozzle continuously connected to said source to operate said first means, and third means responsive to a drop in ambient pressure applied thereto to condition said second means to operate said first means.

14. An automatic pool cleaner comprising a wheel-supported carrier, a tube carried by said carrier having an upper end disposed above said carrier and a lower end disposed adjacent the bottom of said carrier, a water supply conduit connected to the upper end of said tube, a jet drive nozzle connected to said tube above said carrier and operable to receive water from said conduit and drive said carrier, and means associated with said tube to so direct water issuing from the lower end of said tube as to effect a cleaning of the adjacent pool surface, said means comprising a nozzle to direct water substantially parallel to said pool surface and outwardly circumferentially of said tube.

15. The cleaner of claim 14, said means comprising deflector means to direct the issuing water upwardly and outwardly to induce a radially inward annular flow of water beneath said carrier.

16. The cleaner of claim 15, further including means defining with said carrier a compartment to receive leaves and debris which are induced to travel beneath said carrier by said inward flow and are thereafter entrained in said upwardly and outwardly directed water, the latter being directed into said compartment.

17. The cleaner of claim 14, further including means defining with said carrier a compartment to receive leaves and debris which are induced to travel beneath said carrier by the water issuing from said last-men-

12

tioned nozzle, said latter water being directed into said compartment.

18. An automatic pool cleaner comprising a wheel-supported carrier, a water supply conduit, tube means mounted on the carrier for receiving water from said conduit, drive nozzle means rotatably carried by said tube means and in communication with said conduit to drive said carrier and direct the movement thereof back and forth in generally opposite directions, first control means responsive to travel of said carrier at a normal rate in one direction to maintain the positional attitude of said nozzle means, and second control means responsive to travel of said carrier at a lessened or decreasing rate in said one direction to re-position said nozzle means and drive said carrier in the other direction.

19. The cleaner of claim 18, said first control means comprising an annular support member for said nozzle means, a generally horizontally directed tube carried by said support member, a generally vertically directed blade slidably disposed on said tube for inward and outward positioning thereon, and interengaging complementary means associated with said blade and said tube means, operable when said blade is inwardly positioned on said tube in response to ambient water pressure on said blade during travel of said carrier at a normal rate, to lock said nozzle means against rotation.

20. The cleaner of claim 19, said second control means comprising first water-jet discharging means in communication with said supply conduit operable to drive said blade outwardly on said tube, in response to a decrease in said ambient water pressure upon travel of said carrier at a lower rate, to unlock said nozzle means for rotation, and second water-jet discharging means operable when said blade is outwardly positioned on said tube to rotate said nozzle means to drive said carrier in the other direction.

\* \* \* \* \*

40

45

50

55

60

65

# **EXHIBIT**

# **1004**

**United States Patent** [19]

[11] **4,429,429**

**Altschul**

[45] **Feb. 7, 1984**

[54] **DEVICE FOR CLEANING SWIMMING POOL SIDEWALL**

[76] Inventor: **Rod H. Altschul**, 53 Countryside Rd.,  
Newton Centre, Mass. 02159

[21] Appl. No.: **292,159**

[22] Filed: **Aug. 12, 1981**

[51] Int. Cl.<sup>3</sup> ..... **E04H 3/20**

[52] U.S. Cl. .... **15/50 R; 15/1.7;**  
**134/167 R**

[58] Field of Search ..... **15/1.7, 21 R, 49 R,**  
**15/50 R; 134/167 R, 168 R; 114/222**

[56] **References Cited**

**U.S. PATENT DOCUMENTS**

1,466,315	8/1923	Thorsen	15/1.7
3,295,540	1/1967	Ortega	134/167 R
3,315,692	4/1967	Arneson	134/167 R
4,129,904	12/1978	Pansini	15/1.7

**FOREIGN PATENT DOCUMENTS**

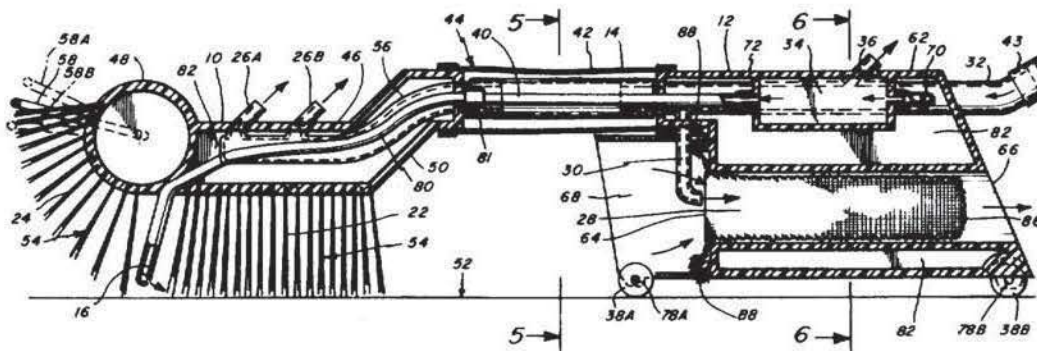
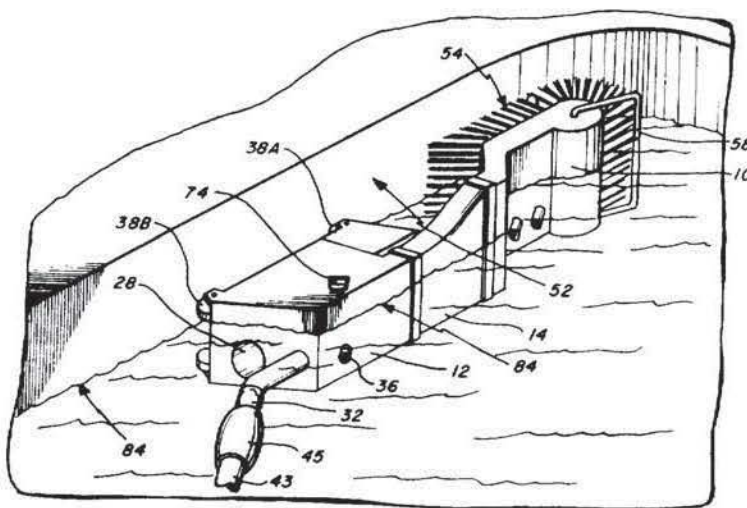
2023593	11/1971	Fed. Rep. of Germany	15/1.7
2138194	3/1973	Fed. Rep. of Germany	15/1.7
584029	1/1947	United Kingdom	15/1.7

*Primary Examiner*—Edward L. Roberts  
*Attorney, Agent, or Firm*—Wolf, Greenfield & Sacks

[57] **ABSTRACT**

A device for cleaning the sidewalls of a swimming pool at the waterline region is self-propelled by water jets which also urge the device against the pool sidewall. The device includes brushes which brush against and clean the sidewall of the swimming pool as the device advances through the water. Means are provided for squirting a cleaning agent against the tiles. In one embodiment, means also are provided for collecting debris and dirt loosened by the brushes.

**33 Claims, 14 Drawing Figures**





4,429,429

1

## DEVICE FOR CLEANING SWIMMING POOL SIDEWALL

### BACKGROUND OF THE INVENTION

#### 1. Field of the Invention

This invention relates to a device for cleaning the sidewalls of a swimming pool in the waterline region, within a few inches above and below the waterline. More specifically, a brush means or the like positioned on the pool cleaning device wipes the tiles of the pool at the waterline region. The pool cleaning device is self-propelled along the pool walls by a water jet system connected to a source of water under pressure. The water jet system acts in conjunction with floatation means to facilitate motion of the pool cleaning device at the waterline so that the brush means is partially above the waterline. In addition, the device has an automatic soap dispensing means for use in conjunction with the brush means. The device is designed to be capable of turning corners to follow the sidewall surfaces of the pool. The water jet system is also utilized in one embodiment of the invention in a system for trapping dirt and debris removed from the tiles by the brush means. A swimming pool ladder guard and a skimmer bypass grate, both specially adapted for use with the device, afford the device unimpeded travel along the swimming pool sidewalls.

#### 2. Description of the Prior Art

Devices for cleaning swimming pools typically have been designed to remove loose debris which sinks to the bottom of the pool, floats on the water surface, or circulates through the water of the pool. While a few vacuum-like devices have been designed to travel along the bottom and lower region of the pool sidewall surfaces, there is no device which is able to clean the upper portions of the pool sidewalls in the waterline region. Typically, the tiles which extend along the upper portion of a swimming pool must be cleaned periodically by hand using cleaning agents and stiff brushes to remove the grime which tends to build up along the waterline tiles.

### SUMMARY OF THE INVENTION

It is among the primary objects of the invention to provide a device adapted to clean the sidewalls of a swimming pool at the waterline region.

More specifically, it is an object of the invention to provide a device which is self-propelled to travel along the sidewalls of a swimming pool at the waterline region.

A further object of the invention is to provide a system for cleaning swimming pool sidewalls at the waterline region which has the capability of turning corners and following the contours of the sidewalls.

Another object of the invention is to provide a device which automatically dispenses soap solution to more efficiently clean the sidewall surfaces of a swimming pool at the waterline region, and which has the further capability of rinsing the soap solution from the sidewall surfaces.

An additional object of the invention is to provide a device of the type described which has the further capability of collecting the dirt removed by the device.

The swimming pool tile cleaning device of the present invention comprises water jet propulsion means, cleaning means, floatation means, water inlet means, and soap-dispensing means. The water inlet means is

2

connected by a floating hose to a source of water under pressure, preferably the pool's water inlet fitting.

The cleaning means is preferably a brush portion which has a curved surface at the leading end, but otherwise has a substantially planar surface. The brush wipes against the sides of the pool as the device advances. The curved brush portion helps the device to initiate turns in the corners of the pool.

The soap-dispensing means is in communication with the water inlet means and includes a soap chamber, which is filled with a concentrated cleaning agent such as soap. Water mixes with the cleaning agent to form a solution which flows to a soap dispenser, which squirts the solution against the swimming pool sidewall near the leading end of the brush means.

The device comprises two or more water propulsion jets, which propel the device in a forward direction while urging it against the swimming pool sidewall. The device also includes floatation material which affords sufficient buoyancy to maintain the device at the proper level in the water, about two to three inches above the waterline as it travels along the sidewalls.

In one embodiment, the present invention also includes a dirt collection means. This embodiment comprises a leading portion which carries the brush and trailing portion which carries the dirt collectors. The leading and trailing portions are joined together by a flexible connecting means so that the device can bend easily and follow the curved contours and corners of the pool. The leading portion also houses the soap-dispensing means. The trailing portion houses the dirt collection filter, the soap chamber, and water inlet fitting. The flexible connection between flexible hoses which carry pressurized water and soap solution from the trailing means to the leading portion.

Floatation means and water jet propulsion means are located on each of the leading and trailing portions. One of the water jets on the trailing portion has the further function of directing a water flow to the collection filter to create suction action to ingest dirt loosened by the cleaning means into a removable filter bag inside the collection means.

In another embodiment of the invention, the dirt collection means and trailing portion are omitted, with all propulsion and guidance jets being carried by a single unit which also carries the brush elements as well as the mixing chamber and dispensing element for the cleaning agent.

### BRIEF DESCRIPTION OF THE DRAWINGS

The foregoing and other objects and advantages of the invention will be appreciated more fully from the following further description thereof, with reference to the accompanying drawings wherein:

FIG. 1 is a somewhat diagrammatic perspective view showing one embodiment of the pool cleaning device as it appears in use travelling along the pool sidewall partially above the waterline;

FIG. 2 is a somewhat diagrammatic top view of the device shown in FIG. 1 partially flexed position as it turns a corner along the pool sidewall;

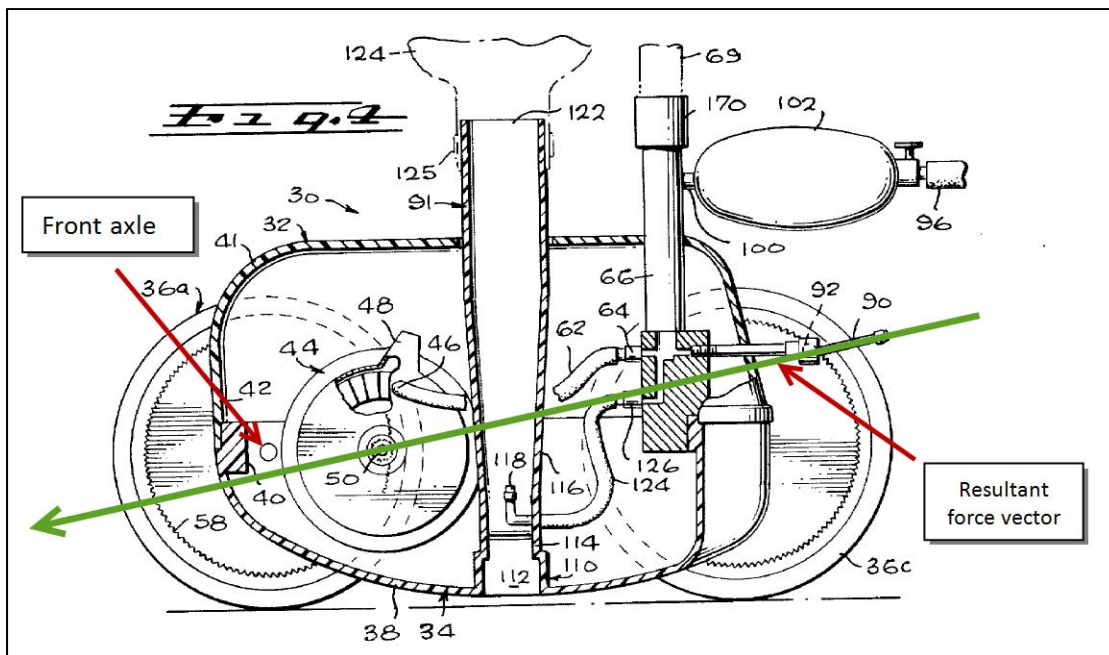
FIG. 3 is a front view of the leading portion of the device shown in FIG. 1 showing the brush and soap dispenser;

FIG. 4 is a plan cross-sectional illustration of the device;

FIG. 5 is a view in cross-section taken along line 5—5 of FIG. 4;

**Henkin in View of Myers**

14. Henkin (Exhibit 1002) discloses a pool cleaner that includes a resultant force vector that has “a downward thrust component (i.e. normal to the vessel surface) for providing traction and a forward component which aids in propelling the car and facilitates the car climbing vertical surfaces and working itself out of corners.” Henkin at 5:19-24. The angle of the resultant force vector is adjustable, as the water jet that produces the resultant force vector exits from “directionally adjustable nozzle 90.” Henkin at 5:8. Below is a modified version of Figure 4 from Henkin. This shows a resultant force vector of Henkin with the directionally adjustable nozzle 90 in one possible position, and identifies the axel of the front wheel.



15. The resultant force vector of the Henkin cleaner passes underneath the front axle of the cleaner. The same resultant force vector is also directed to a position proximate to and rearwardly displaced from the front axis of rotation and passes proximately to and rearwardly of at least one plane containing the front axis of rotation. As a result, the

resultant force vector would tend to keep the Henkin cleaner in a stable, upright position during operation. The Henkin cleaner would not tip over and become an unstable machine if it were to hit a wall or step as described by Mr. Erlich in Exhibits 2010A-2010F.

16. It is inherent that the directionally adjustable nozzle 90 of Henkin could be adjusted from the position shown in Figure 4 to provide a greater downward thrust to provide more traction. This is inherent because the purpose of a directionally adjustable nozzle is for an end user to adjust to nozzle to achieve desired performance. For example, different pools may have different surface roughness where various nozzle angles may be needed to maintain traction.

17. Assuming *arguendo* that it is not inherent to adjust the nozzle 90 to direct the resultant force vector to the surface directly beneath the cleaner, one of ordinary skill in the art would be motivated to combine the direction of the resultant force vector of Myers with the Henkin cleaner to further increase the downward thrust component for providing traction to further increase the stability of the cleaner.

**Pansini in View of Myers**

18. Pansini (Exhibit 1003) discloses a pool cleaner that has a water jet force, wherein the water for the jet is pressurized by the pool filter system pump. Pansini at 2:61-65, 3:12-13.

19. It would be obvious to one of ordinary skill in the art to combine the internal pump of Myers with the Pansini cleaner to eliminate the need for an external source of pressurized water. Further, one of ordinary skill in the art would be motivated to combine these references because both cleaners are using a water jet to propel the cleaner.

**IN THE UNITED STATES PATENT AND TRADEMARK OFFICE**

In the *Inter Partes* Review of:

U.S. Patent No. 8,273,183

Filed: July 12, 2011

Issued: September 25, 2012

Inventors: Giora Erlich et al.

Assignee: Aqua Products, Inc.

For: AUTOMATED SWIMMING POOL  
CLEANER HAVING AN ANGLED  
JET DRIVE PROPULSION SYSTEM

Attorney Docket No.: 222,604

Case No. IPR2013-00159

Panel: Administrative Patent  
Judges Brian McNamara, Rama  
Elluru and James Arpin

**CORRECTED DECLARATION  
OF GIORA ERLICH IN  
SUPPORT OF PATENT  
OWNER'S REPLACEMENT  
CORRECTED MOTION TO  
AMEND CLAIMS AND  
PATENT OWNER'S  
RESPONSE TO PETITION  
FOR *INTER PARTES* REVIEW**

1. I, Giora Erlich, declare as follows:

2. The facts stated are based on my personal knowledge.

3. I submit this declaration in support of Patent Owner's Replacement Corrected Motion to Amend Claims and Patent Owner's Response to the Petition for *Inter Partes* review.

**QUALIFICATIONS**

4. I am a mechanical engineer. I received a bachelor's degree in mechanical engineering from Technion Israeli Institute of Technology in Haifa, Israel in 1964.

Aqua Products, Inc.  
Exhibit No. 2016  
Zodiac Pool Systems, Inc. v. Aqua Products, Inc.  
Case IPR 2013-00159

5. After two (2) years in the Israeli army, where I was a project engineer with responsibilities directed to military tank modification and conversion, I came to the United States and became employed by Pall Corporation (Long Island, New York), and served as a project engineer in the development of filtration and flow control systems used in the aerospace industry.

6. From approximately 1967 until 1970 I was Vice President of engineering and research and development for Hayward Manufacturing Company, Inc. At the time of my employment, Hayward Manufacturing Company, Inc. was a leading manufacturer of swimming pool equipment and supplies in the United States.

7. From 1982 until 1985, my company, Aqua Products, Inc. was the North American distributor and service provider for the robotic pool cleaners manufactured by Maybar Ltd., an Israeli company and its U.S. subsidiary, Aquatronics, Inc. In addition, we also repaired and serviced these robotic pool cleaners. Maybar, Ltd. is today known as Maytronics, Ltd. Maybar's main product was called the "Dolphin" robotic pool cleaner which was the first modern robotic pool cleaner sold in America. The Dolphin pool cleaner included an electric drive motor, drive gear box, complex control circuitry which created a controlled pattern of movement, and a pump motor to provide suction for debris removal and a positive vertical downward force to maintain the robotic cleaner in

contact with the bottom of the pool. This basic configuration remains the same for robotic cleaner designs with electric drive motors that are used worldwide today.

8. In 1982, I established Aqua Products, Inc. (“Aqua Products”) to act as the North American distributor and service provider for the Dolphin products. In 1985, I terminated my relationship with Maybar, Ltd., and partnered with Joseph Porat and started to manufacture electric motor driven robotic cleaners known as the “Aquabot” cleaner.

9. During this time, I was a principal and held positions as the Executive Vice President and subsequently the President of Aqua Products from 1982 until 2010. In 2010, Fluidra, S.A. (“Fluidra”) acquired a controlling interest in Aqua Products. I am presently a Board member of the Aqua Group of Fluidra and still assist Aqua Products in its R&D efforts.

10. I have been involved in the research and development of pool cleaning technology since 1982 and I am intimately familiar with the prior art of automated and robotic swimming pool cleaners. I have a world-wide reputation as a qualified expert in the field of robotic cleaners.

11. I have been named as an inventor or co-inventor in at least 20 U.S. patents in the pool cleaner field and am also one of the co-inventors of U.S. Patent No. 8,273,183 (“183 Patent”), which is the patent at issue in this IPR proceeding (Exhibit 1006). In 1999 I was fully knowledgeable of the robotic pool cleaner

marketplace and its competitors and my knowledge of the industry remains comprehensive today.

12. I have reviewed the August 23, 2013, Decision of the United States Patent and Trademark Patent Trial and Appeal Board (“Board”) in this matter. It is my understanding that the Board has determined that certain claims of the ‘183 Patent (Exhibit 1006), *i.e.*, 1-9, 13, 14, 16 and 19-21, will be reviewed in this proceeding and the remaining claims will not be reviewed.

13. I have also reviewed certain of the prior art cited by the Board in the Decision, that is, U.S. Patent Nos. 3,321,787 to Myers (“Myers” or “787 Patent”) (Exhibit 1001), 3,936,899 to Henkin (“Henkin” or “899 Patent”) (Exhibit 1002) and 4,100,641 to Pansini (“Pansini” or “641 Patent”) (Exhibit 1003). As well, I have reviewed other prior art which I believe will assist in a better understanding of the state of the technology in 1999 and the radical departure from known technology embodied in the invention described in the ‘183 Patent (Exhibit 1006).

### **SUMMARY OF CONCLUSIONS**

14. Set forth below is a summary of the conclusions I have reached:

- (a) In 1999, based on my observations in the field, there was a long-felt need for a simpler, lower cost and more reliable self-propelled, electrically powered and electronically controlled robotic pool cleaner. This was especially necessary in areas

such as the Sun Belt where there was a need for cleaners capable of withstanding extended daily operation which was not required in the Northeast. The result was a cleaner that employed an internal pump which provided suction to clean the surfaces below the cleaner, as well as propelling the cleaner along the submerged surface of the pool without separate drive motors to rotate the wheels and/or brushes, and as well maintaining contact with the pool surface.

- (b) The cleaner I designed includes an angled jet drive, which is critical in producing a resultant force vector that has a downward component and a forward component, and which is directed to a position beneath the surface of the cleaner, and more particularly, proximate to and rearwardly of the axis of rotation of the front rotationally-mounted supports (e.g., front wheels).
- (c) The commercial embodiments of the '183 Patent were met with overwhelming success, and indeed our competitor exhibited interest in our "jet drive" technology.



- (d) I am unaware of any prior art from 1999 and earlier that disclosed a jet drive implemented in the manner I developed or even suggesting such an implementation.

### **THE '183 PATENT**

15. The '183 Patent discloses a self-propelled electrically powered robotic cleaning apparatus for cleaning a submerged surface of a pool or tank.

16. One important feature of the '183 Patent is the discharge of a pressurized stream of water which forms a water jet that is directionally discharged at an acute angle with respect to the surface over which the apparatus is moving. This feature is critical to the stability of the cleaner and enables systematic, rather than random movement over the surfaces of the pool.

### **THE POOL CLEANER INDUSTRY IN 1999**

17. I have been advised that in evaluating issues of patentability, the prior art is evaluated on the basis of what is disclosed to a person of ordinary skill in the field at the time of the invention. In 1999 and earlier, pool cleaning, particularly through the use of an in-pool apparatus was a relatively small industry and many of those involved in product design were self-taught, although some had technical training or degrees. A person of ordinary skill in the art of robotic pool cleaners in 1999 would therefore have possessed at least three (3) years of work in the field with some technical training.

18. The number of manufacturers of robotic swimming pool cleaners in the United States today is relatively small with only five major suppliers. These are Aqua Products and Petitioner, Zodiac Pool Systems, Inc. (“Zodiac”), Maytronics, Smart Pool and Hayward. In 1999, to my recollection, the field was even smaller with only one other major competitive manufacturer to Aqua Products, i.e., Maytronics.

19. To be clear, in 1999 there were other pool cleaner apparatus companies that had automated features to assist in pool cleaning. However, they were not “robotic” pool cleaners, i.e., controlled pattern pool cleaners that included electrically driven motors and a power cable connected to an external source of power, which in turn required a directionally controlled movement to prevent twisting of the cable. In 1999, these companies (including Polaris, now owned by Zodiac) criticized and described electrically powered robotic pool cleaners as being dangerous because of the use of electrically powered components in water.

20(a). As the commercial success of the robotic motor driven cleaners increased (especially in the Sun Belt), so did the time of usage and with it motor servicing issues and utility costs. The pool cleaning markets in the Northeast and Mid-West of the US was approximately a 20-week season, and the cleaners were used 20-30 times a year. In the Sun Belt areas, the season is year-round and the cleaners operate approximately 20-30 times per month. The robotic motor driven

cleaners prior to 1999 normally required approximately 5-7 hours to clean a standard 20x40 residential swimming pool. These long hours of operation resulted in excessive wear and tear and a high failure rate of the drive motors and drive train components.

20(b). In or about 1999, Aqua Products was developing its innovative electric powered water propulsion pool cleaner. The objective was to create a robotic pool cleaner that could move the cleaner in a controlled forward direction over a submerged surface of a pool or tank by directionally discharging a pressurized stream of water from a discharge conduit. The pressurized stream of water was generated by a water pump positioned in the cleaning apparatus to draw water and debris into its filter bag. The pump expelled filtered water back into the pool through an angled discharge conduit which eliminated the need for motorized drives that rotated the wheels or brushes. This type of propulsion technology is referred to by Aqua Products as a “jet drive” system.

20(c). I also note that the Board made an observation in the Decision (Decision at page 26) that electric power to a cleaner could have alternatively been provided by battery power. Using an internal battery or battery pack was not feasible in 1999 to me or any one else of ordinary skill in the art because of the long duration of the cleaning operations (upwards of 5 hours), which would have required large and heavy batteries to last for these time periods without recharging or replacing.

Further, the additional weight of the batteries would have prevented the cleaner from climbing a vertical sidewall of the pool. Indeed, when I contemplated viably implementing the concept of using batteries to power the cleaner, the electric power still had to be provided from an external battery, such as with an external battery provided on a floating platform, which was subsequently described by my partner, Joseph Porat, in U.S. Patent No. 7,089,876. In 1999, the only feasible means of providing power to the internal pump of the robotic motor driven cleaners and my jet drive cleaner was by an external power supply via a power cable.

21. The jet drive abilities of this new Aqua Product design was an immediate success. It replaced the whole drive motor, gear box and expensive circuit board, which controlled the motor and provided its preprogrammed movement pattern. As well, the jet drive eliminated the need for a drive system that required pulleys, drive belts, drive tracks, bearings and wheel tube assemblies. Aqua Products' jet drive provided a less expensive, reliable and less complex robotic cleaner that would clean the entire pool in a much faster and more thorough way than any other robotic cleaner (and indeed could climb the pool walls). Most of the costs associated with powering and maintaining the motorized drives and its associated hardware were eliminated.

## **USE OF PUMPED WATER TO ASSIST CLEANING**

22. Based on my knowledge, experience and judgment, the prior art in the field did not provide any guidance or teaching of the approach taken in the '183 Patent.

By 1999 there were three different approaches to automated pool cleaners:

- (a) **Suction side cleaners** – These types of cleaners used the pool's filtration system/skimmer and a vacuum head that was positioned on the surface of the pool and connected to the filter system's pump via a long suction hose. There were several cleaners which used an apparatus to create automated movement of the vacuum head. These devices, commercially sold under the "Kreepy Krauly", "Pool Vac" and "Barracuda" trademarks, were extremely inefficient from an energy consumption standpoint because the cleaner moved (i) by a vibratory/pulsed motion that caused the vacuum head to randomly "bounce" along the pool bottom (U.S. Patent No. 5,293,659, Rief, et. al. Exhibit, 2005) or (ii) with "walkers" positioned at the bottom of the vacuum head. (Barracuda U.S. Patent No. 5,720,068, Clark, et. al. [Exhibit 2006] and the Hayward Industries "Pool Vac"). They were all inexpensive,

but were also energy inefficient and were based on random motion in the pool.

- (b) **Pressure side cleaners** – These cleaners are typified by the Henkin patent (which was sold under the “Polaris” trademark), and used the water pressure from an external high pressurized booster pump or the pool’s circulation and filtration pump to drive turbines which in turn, turned two of the three wheels of the apparatus. The external pump also produced an upward suction to collect some of the debris, as well as drive a flexible hose which acted as a “tail” (See Exhibit 1002, FIGS. 1, 2 and 4, #96) that stirred up the debris to be collected by the main drain and the skimmers of the pool. The principle of operational movement relied upon a **random** movement, employing a three wheel “outboard” arrangement with a pivoting rear caster as the third wheel to generate even more randomness of the movement. A small adjustable nozzle is included to provide for a minimal degree of assistance in motion and/or surface contact. (Exhibit 1002, FIGS. 1, 2 and 4, #90). Movement in a **highly** random manner was critical. (Exhibit 1002, col. 7, lns. 45 -51). Due to the highly random

movement, the use of an internal electrical pump was not feasible because of twisting and knotting of the electric power cable from the external power supply.

- (c) **Robotic Motor Driven Cleaners** – These cleaners such as those sold under the Dolphin or Aquabot trademark included two types of electric motors. One motor was to drive the wheels and a second motor provided the cleaning function by drawing water and debris from beneath the cleaner and discharging filtered water through an outlet formed at the top of the unit.

23. U.S. Patent Nos. 3,291,145 and 3,817,382 to Arneson (Exhibits 2007 and 2008, respectively) are other examples of the pressure side cleaner which relied upon the pool's pumping and filtration systems or booster pumps as the main source of cleaning. The objective of this type of cleaner was primarily (like Henkin) to create turbulence and agitate debris settled at the pool bottom so that it could be entrained and held by the pool's filtration system. The cleaning unit was positioned on or about the surface of the pool and employed the pool's filtration system or a booster pump to expel streams of pressurized water through submerged hose-like extensions which whipped about and stirred up and suspended the debris at the pool bottom. In essence, Henkin employs this technology, but brought the

unit to the bottom of the pool to pick up some of the debris. The random movement of the Henkin apparatus within the pool was not intended to fully cover the bottom of the pool in a controlled pattern. Quite to the contrary it was intended for random movement of the cleaning unit, which resulted in longer cleaning time and therefore higher operational costs.

24. These pressure side cleaners may include a water jet discharge conduit, but the water jet in these designs have numerous drawbacks, including a negligible propulsive force, random movement, and would become immobilized in sharp corners or on steps of pools. To the extent the water jet created by a pump was employed in these types of cleaners (whether internal or external) to assist movement, the manner of discharge from the water created an inherent instability of the cleaner. This may have been acceptable in random movement devices, but was unacceptable in robotic devices. It is important to note that a hose-connected device could move randomly without twisting the hoses because it included a relatively simple hose swivel.

25. Although robotic motor driven cleaners used electric energy to operate, the costs were significantly less than devices that relied upon the pool's main external circulation and filtration systems and booster pumps to remove the agitated debris. In those pressure-side devices, these two pumps would need to operate at the same time in order to remove most of the dirt and debris suspended in the pool's water.



## **DEVELOPMENT OF THE INVENTION**

26. Prior to my invention, robotic pool cleaners utilized motorized drive mechanisms for controlled movement and included internal drive motors to rotate the wheels or brushes to assist in patterned movements, and a separate internal pump for creating suction power and maintaining the pool cleaner in contact with the pool surface. The internal pump applied a general downward force which helped stabilize the cleaner. Although robotic pool cleaners, when out of the water, have significant weight, when it is in the water they are designed to be substantially weightless. To operate, they must maintain contact with the pool surface. This contact was provided by the downward force of the pump. An example of one of the earlier devices is disclosed in U.S. Patent No. 4,168,557, Rasch (Exhibit 2009).

27. Although electrically driven motorized robotic pool cleaners became widely accepted, the greater daily usage (particularly in Sun Belt areas of the U.S.) resulted in greater wear on the motors and greater frequency of repair as well as greater energy usage. The use of drive motors resulted in the need for associated drive gear boxes and a drive system that included an electronic motion and control circuit board, pulleys, bearings, drive belts and drive tracks.

28. An electrically driven system requires a controlled movement both to assure coverage and to prevent twisting or distortion of an electrical cable. In

1999, preventing this twisting or distortion by including a rotational mounting of an electric cable under water was problematic, and extremely expensive. Therefore, a controlled direction of movement was critical.

29. The basic idea of eliminating the drive motor and drive train, and replacing them by using the existing internal pump in a different way was revolutionary. Indeed, using self-propelled controlled cleaning robots having an internal pump as a functional drive mechanism was never done by anyone prior to our jet drive system and was thought to be impractical and not workable prior to 1999.

30. Prior to 1999, my co-inventor and I conceived a solution. This solution was embodied in a self propelled robotic cleaner that included an internal filter and internal pump for drawing water and debris through the filter, and discharging the filtered water as a pressurized stream of water which is specifically angled not only to propel the cleaner, but also to maintain surface stability. The pressurized stream of water was discharged at an acutely angled trajectory that produced a resultant force vector with a horizontal component and a vertical component.

31. The following graphical illustrations show what I discovered regarding the trajectory of the resultant force vector and why the angle of it is critical to the operation of the cleaner. A cleaning unit having a jet stream that produces a resultant force vector directed downwardly and forward of the axis of rotation of

the leading wheels can result in unstable operation of the cleaner. (Exhibits 2010A to 2010F).

- (a) Illustration A (Exhibit 2010A) is a copy of Fig. 9 from the '183 Patent modified by inclusion of a vertical line "W" representative of a vertical sidewall of a pool that is perpendicular to a bottom surface over which the pool cleaner is moving.
- (b) Illustration B (Exhibit 2010B) shows the pool cleaner having advanced to the base of the wall W while the water jet continues to be discharged from the conduit 120R at an angle  $\alpha$  to produce a resultant force vector  $V_r$  that passes proximate the axial mounting of the rotationally mounted front wheel 30 and displaced rearwardly. The position of the resultant force vector  $V_r$  includes a sufficient vertical component to maintain the pool cleaner on both the horizontal bottom surface of the pool, and on the vertical surface of the pool wall. (In accordance with any one of several disclosed modes of operation, after coming to rest at the sidewall W of the pool, an internal flap valve changes position and the water jet is discharged from conduit 120L to propel the cleaner away from sidewall W.)

- (c) Illustration C (Exhibit 2010C) is similar to illustration A, except that the discharge angle has been lowered to  $\alpha'$ , thereby producing a resultant force factor  $Vr'$  that passes over the front axial wheel mounting 32.
- (d) As shown in illustration D (Exhibit 2010D), when the cleaner reaches the vertical sidewall, the position of the force vector  $Vr'$  produces a force that tends to raise the rear of the cleaner from the horizontal surface by pivoting the body around the front axial mounting 32.
- (e) Illustration E (Exhibit 2010E) shows the pool cleaner in an unstable position with the rear wheel above the horizontal surface and the unit rotated against the vertical wall W, the motion of which is limited by contact with a portion of discharge conduit 120L. In pool cleaners designed with water jet conduits that do not project as schematically illustrated in these series, the resultant force vector  $Vr'$  can cause the unit to assume a highly unstable position on the front of the housing 12, and the unit can tilt over to one side or even come to rest on its top surface so that cannot recover an upright position.

- (f) Illustration F (Exhibit 2010F) shows the pool cleaner having contacted a step "S" and tipped to a vertical highly unstable position from which it may not recover to an operative position.

32. Although the degree of instability may vary with each contact with a wall, step or other obstacle, it may potentially render the cleaner functionally inoperative.

33. I have reviewed the description in the patents to Meyers (Exhibit 1001), Henkin (Exhibit 1002) and Pansini (Exhibit 1003). None of them have or suggest the approach I have taken.

34. The Myers patent apparatus is not intended for a controlled movement. It is premised upon the concept that random, uncontrolled pattern movement is essential to its operation (See Exhibit 1001, col. 2, lns. 47-55). The exiting water stream does not create a force vector that results in providing stability when contacting a vertical wall or step. Further, if the Myers patent included an electric power cable to an internal pump, it would have quickly become twisted, rendering the cleaner inoperable.

35. The Henkin patent provides some adjustment to the water jet angle, but in all cases the resultant force vector is directed ahead of the cleaning apparatus, as opposed to being directed to a position that is beneath the cleaner or proximate to and rearwardly displaced from the axle of the front pair of wheels. While the

water jet in Henkin could potentially assist the water-driven turbines' wheels in moving the apparatus, it does not overcome the instability that often accompanies contact with a vertical wall or step – and the movement is intended to be random. If the Henkin patent included an electric power cable to an internal pump, it would have quickly become twisted.

36. Similarly, Pansini discloses a resultant force vector that is directed forward of a transverse axial mountings of a front pair of wheels, as opposed to being directed to a position that is beneath the cleaner or proximate to and rearwardly displaced from the axle of the front pair of wheels. Again, there is no recognition of the instability issue regarding the cleaner maintaining contact with the surface or potentially turning upside down. Further, if Pansini included an electric power cable to an internal pump, it would have quickly become twisted.

### **EVIDENCE OF NEW AND UNEXPECTED RESULTS**

37. In or about 2001, the use of the technology disclosed in the '183 Patent was incorporated in a line of jet drive robotic cleaning devices known as the "Pool Rover" which revolutionized the robotic pool cleaning industry by quickly, reliably, efficiently and systematically cleaning the entire pool.

38. The benefits of the invention included lower production costs, lower repair and maintenance costs, less down time for maintenance and repairs, less consumption of power to drive the cleaner and improved stability while moving

along the controlled cleaning pattern. Also, the efficient movement of the cleaner saved time, energy and wear of the cleaner at a much lower cost than other commercially available robotic motor driven cleaners. The number of customer inquiries and end-user complaints regarding operational issues for the Pool Rover decreased by approximately 90% by comparison to the motor driven Aquabot cleaner even though the Pool Rover was a brand new product. The improved stability from the angled resultant force vector directed at the surface beneath the cleaner was immediately apparent to me based on the favorable comments of our customers and end-users.

39. Prior to 1999 and during the period that Aqua Products was developing its jet drive system, no other commercially available pool cleaner existed in the market which utilized this technology. In fact, there was no commercially available pool cleaning devices which effectively utilized jet drive technology as the main source of propulsion without the use of motorized drive mechanisms until Aqua Products introduced its Pool Rover.

40. Consumers have exhibited a very positive reaction to Aqua Products jet drive cleaners purchasing well in excess of 100,000 units in the first ten (10) years from its introduction. Sales have increased every year since 2002. Within approximately four (4) years from the introduction of the Pool Rover, annual sales

exceeded ten thousand (10,000) units. Today these sales represent more than 2/3 of all of Aqua Products' robotic pool cleaner sales.

41. In or about 2002, our competitor, Zodiac, exhibited significant interest in our jet drive pool cleaners, and indicated that it was interested in purchasing Aqua Products. Exploratory discussions between the two companies were held at Aqua Products' headquarters in Cedar Grove, New Jersey.

42. Zodiac representatives, including Mr. Jean Marc Daillance, the Chief Operating Officer of Zodiac as well as Mr. Jean Michel Renard, Zodiacs' President, toured Aqua Products' facilities and observed products and manufacturing operations including those related to Aqua Products' proprietary propulsion technology. In addition, detailed technical specifications for jet drive devices were disclosed to Zodiac.

43. At the time of this meeting, I observed the Zodiac representatives as being surprised both by their comments and visual reactions to the jet drive. Zodiac acknowledged that they never contemplated a commercially reliable controlled movement jet drive. Aqua Products was later advised by Zodiac that it had to defer further discussions due to internal Zodiac reorganizational issues.

44. Contact with Zodiac was established again in 2008. At that time, Zodiac was interested in either distributing jet drive units for or purchasing private label jet drive units from Aqua Products. As part of that initiative, Aqua Products



provided several jet drive robotic pool cleaners to Zodiac for purposes of evaluation. Copies of the order confirmation and invoice for the sale of these pool cleaners from Aqua Products to Zodiac are attached to this declaration as Exhibit 2011 and 2012 respectively.

45. After receiving and testing samples of Aqua Products' jet drive products, Zodiac expressed interest in a possible "joint venture" with Aqua Products.

46. Later in 2008, a follow up meeting between Aqua Products including myself and Zodiac's top management and personnel including many who were identified as executives and technical personnel was held at Zodiac's facility in or near Chatsworth, California.

47. At this meeting, I made a presentation to approximately fifteen to twenty of Zodiac's top business and technical personnel. We discussed the possible joint venture, with most of the discussion centered on Aqua Products' jet drive cleaners. During that meeting the parties discussed providing the jet drive technology of Aqua Product for use in Zodiac's products.

48. I explained the advantages of the jet drive technology over Zodiac's then Polaris product which was based on the Henkin patent.

49. Sometime after the meeting, Zodiac advised me that due to the economy's collapse, it did not want to enter into the proposed joint venture.

50. Nevertheless, Zodiac obviously recognized the breakthrough development in jet drive propulsion technology and it is my understanding that Zodiac also filed a patent application relating to jet drive propulsion technology.

51. In or about 2009, Zodiac introduced its new Polaris line of robotic pool cleaners which incorporated a jet drive propulsion system that produces an angled jet drive with a resultant force vector that is directed toward the surface of the pool beneath the cleaning apparatus, and more specifically, proximate to and rearward of the axis of rotation of the front wheels or brushes. This jet drive technology is present in Zodiac's 9100, 9300 and 9400 series models. Today, sales of the Zodiac's Polaris 9100, 9300 and 9400 models of pool cleaners and the Aqua Products' Pool Rover pool cleaners collectively constitute the vast majority of the jet drive robotic pool cleaner sales in the United States. Without the jet drive propulsion, commercial success of the new Polaris and Pool Rover products would not be possible.

### **THE "FRONT" OF THE APPARATUS**

52. I have reviewed the Board's analysis of the claims of the '183 Patent and in particular that portion of the claim that relates to the interrelationship between apparatus and its direction of motion.

53. It is my understanding that the Board concluded that based upon the wording used, whatever direction the cleaner travels becomes the “front portion” of the unit and, therefore, the “direction of movement”. (Decision at 19).

54. The Board observed that “the direction of movement may change depending upon which [water jet discharge] conduit ejects the water.” (Decision at 5). The ‘183 cleaner has consistently disclosed two opposing water jet discharge conduits. The Board further concluded that the language of claim 1 “describes the front portion based on (1) the direction of movement of the apparatus, and (2) the time, e.g., “when” the apparatus is propelled by the water jet.” *Id.* at 10. The Board further concluded that “the front portion of the housing may change with time, and no single portion of the housing may be identified exclusively as the front portion.” *Id.* at 11.

55. The Board’s interpretation of “front” and “rear” of the cleaner was not the meaning I understood nor one that would be understood by one skilled in the art particularly because the claim further uses singular words such as “a” or “the” or “said” to refer to the front of the cleaner. Thus, to my understanding, as appears in most dictionaries, the singular modifier describes a constant (not variable) front during the forward direction of movement. (*See, e.g.,* Exhibit 2014 - “a” as defined in Webster’s New World Dictionary (2<sup>nd</sup> ed. 1984).

56. Thus, for example when Claim 21 states:

“a housing having a baseplate with at least one water inlet, and further including a front portion as defined by the direction of movement of the cleaning apparatus when propelled by a water jet, an opposing rear portion and adjoining side portions defining the periphery of the apparatus...”

it is defining a single “front portion” that remains in constant alignment with the water jet which is propelling the cleaner in a forward direction. This is demonstrated in Figure 1A of the ‘183 Patent.

57. I have been advised that the interpretation of the Board is not subject to review. However, I wanted nonetheless to point out what I believed to be an overly broad reading of the claims of the ‘183 Patent, which permitted the Board to find all of the claimed elements in the Myers patent. However, as set forth below, even if the Board’s interpretation is correct, Myers does not necessarily move in the direction of the “front”.

## **THE CITED PRIOR ART AND CLAIM 21**

### **The Myers 787 Patent**

58. Myers does not have “a front portion as defined by the direction of movement of the cleaning apparatus when propelled by a water jet” and

“propelling the apparatus in **a forward** direction of movement” because Myers, when moving, does not necessarily follow the path being urged by the jet drive.

59. Although Myers will be urged to move by the jet, the direction of the movement is erratic. Due to the rotation of the angular brushes, the movement may not and, based upon my understanding of what is described in the patent, generally will not be in the direction of the exiting water jet. There is no constant movement in the direction of the discharge of the water jet as is present in the ‘183 Patent. Although the “front” may be urged forward, the body may move sideways. Therefore at different times the movement may be towards the “front” or “sides”. There is no “single” direction at a given time while being propelled by the water jet nor is the direction of movement necessarily to the “front.”

60. Myers is generally oval in shape and the pump outlet is provided asymmetrically on a top end of the housing. (Exhibit 1001, FIG. 1 and 2) The water jet of the Myers cleaner has an ancillary force vector intended to work in conjunction with the single projecting swivel wheel and the pair of brushes that are axially mounted at an acute angle displaced slightly from the vertical to create an erratic movement. (See Exhibit 1001, col. 2 lns. 59 - 63; FIG. 1 (swivel wheel 41)) This arrangement of the three elements: water jet, counter-rotating angularly mounted brushes and the single displaced swivel wheel collectively will cause the Myers cleaner to rotate erratically, more randomly and not necessarily in the

direction of movement of the apparatus. The angular displacement of the swivel wheel from the direction of the horizontal force vector produced by the discharged water stream may assist in propelling the cleaner in some direction, just not necessarily forward. Claim 21 of the '183 Patent describes the water exiting direction and a correlated movement direction. Myers does not have this feature.

61. Myers identifies numerous other factors that contribute to the highly erratic movement including the configuration and arrangement of the scrubbing brushes, the angles of the brush drive shafts, and the swivel wheel. See Myers (Exhibit 1001), col. 2, ln. 47 to col. 3, ln. 25. The erratic movement requires the swivel wheel to stabilize it from tipping over. In other words, the cleaner essentially spins as it moves and the direction of the existing water stream notwithstanding, the direction of the movement may not be forward. Thus neither the direction of movement nor the 'front' is constant. In my experience, this spinning and erratic motion would cause an uncontrolled twisting and coiling of the electrical cable which would quickly render the device inoperable, while the apparatus disclosed in claim 21 does not encounter this problem.

62. Therefore, even if Myers disclosed the claimed force vector (which it does not) Myers does not have all of the features of claim 21 even under the Board's interpretation of the claim.

**Claim 21 Is Not Obvious (Henkin '899 Patent and Myers '787 Patent)**

63. I have studied both Henkin and Myers for an explicit or implicit disclosure of “discharging the filtered water through the directional discharge conduit at an acute angle with respect to the surface over which the apparatus is moving, said discharged filtered water forming a water jet having a resultant force vector acutely angled towards the **surface beneath the apparatus**” (emphasis added) and have found none.

64. In Henkin, the jet stream nozzle is mounted on a universal fitting and the angle of the nozzle must be manually selected, as opposed to being fixed at a specific angle during manufacture of the apparatus. The nozzle is preferably mounted on some type of universal fitting such as a ball coupling which couples the nozzle to the supply manifold for receiving a water supply from a booster pump. The angle is selected to yield both a downward thrust component, i.e., normal to the vessel surface, for providing traction and a forward component which aids in propelling the apparatus. Set means can be provided for holding the selected angle of the nozzle and valve means for varying the flow rate through the nozzle. (See Henkin, col. 5, lns. 15-27.) However, there is no recognition that the angle should be selected to provide a resultant force vector that is directed to the surface beneath the cleaning apparatus. The ability to randomly select the angle exhibits a total lack of recognition of the importance of any particular angle for purposes of

stability. As stated in the Henkin patent – and as I can acknowledge by my experience, stability is provided by having a lighter top portion, a heavier bottom with a low center of gravity, and an almost balloon-like bag that is vertically attached to and above the body to keep it stable. (See Exhibit 1002, FIG. 2).

65. The angle illustrated in the preferred embodiment of Henkin further supports this because it does not result in a force vector trajectory “towards the surface beneath the apparatus.”

66. As noted, Myers also does not disclose a resultant force vector that is directed towards the surface of the pool beneath the cleaner as is required by claim 21 of the ‘183 Patent. Myers generally states that the outlet of the pump is capable of serving to jet a stream of water for propelling said chassis over the floor of a swimming pool. (See Myers, col. 7, Ins. 46-48). The “resultant force vector” from the Myers water jet stream may assist in propelling the cleaner, but it also contributes to the erratic turning of the cleaner caused by the swivel wheel and rotating brushes. To achieve its purpose, the resultant force vector of Myers can be directed almost in any direction to further contribute to the erratic movement of the cleaner. Controlled directional movement is neither disclosed nor suggested.

67. In my invention “the angle “ $\alpha$ ” [of the resultant force vector] is critical to the proper movement of the robot 10 while on and off the vertical or angled side wall of a pool.” ‘183 Patent (Exhibit 1006), col. 10, Ins. 60-64. The resultant force



vector  $V_r$  is directed beneath the cleaner to provide a longitudinal force vector component, while at the same time exerting a downward force component to help maintain the cleaning apparatus along the surface being cleaned. The forward and downward force components of the resultant force vector are particularly important when climbing a vertical surface that is substantially normal to a horizontal bottom surface of the pool. The forward component assists propelling the cleaner up the sidewall and the downward force component assists in maintaining the cleaner along the surface of the pool.

**Claim 21 Is Not Obvious (Pansini '641 Patent and Myers '787 Patent)**

68. In Pansini, the angle of the nozzle tubes produce a resultant force vector that is directed forward of a transverse axial mounting of a front pair of wheels and the resultant force vector is angled somewhat downwardly in front of the Pansini cleaner to propel it along the bottom surface of the pool. The angle of the resultant force vector of Pansini is not directed toward the surface beneath the cleaning apparatus. Pansini also suggests use of a somewhat upwardly angled nozzle to discharge water to help stabilize the cleaning unit. However, this cleaning unit remains unstable. The very nature of the design is unstable as the rear end of the housing is subject to flipping upward upon contact with an opposing sidewall of the pool.

69. I disagree with the unsupported assertion by the Petitioner that the internal pump of Myers could be used in place of the external pump. Pansini did not believe it desirable to have an internal pump given its design and despite the very significant increase in cost of operation of a pool pumping system versus an internal pump. Even with an internal pump, the Pansini patent would still encounter problems with power cable entanglement.

70. I have reviewed the file history of the Pansini application. It reveals that a cleaning apparatus using an external pump was highly susceptible to being tipped over by the drag force of the hose which provided the water source to propel the cleaning device. (Exhibit 2013 at Paper No. 8, page 25, canceled claim 19). In other words, Pansini's invention related to solving the problem of **using** an external pump, not eliminating it.

71. Pansini's water discharge nozzles were included to offset the resulting drag forces produced by the water supply hose extending from an external water source. (Exhibit 2013 at Paper No. 8, pg. 25). Myers also employs an external water source to operate the cleaning device. (Exhibit 1001, col. 2, lns. 13-18).

72. Neither Pansini nor Myers disclose or suggest "discharging the filtered water through the directional discharge conduit at an acute angle with respect to the surface over which the apparatus is moving, said discharged filtered water forming a water jet having a resultant force vector acutely angled towards the

surface beneath the apparatus.” Even if the Pansini apparatus somehow operatively included the internal pump provided in the Myers patent, it would still not contemplate the use of a resultant force vector acutely angled toward the surface beneath the apparatus. An electric power cable will quickly become twisted due to the constant turning and random movement of this cleaner in a pool.

### **THE PROPOSED AMENDED CLAIMS**

73. I understand that Aqua Products has requested that it be allowed to amend claims 1, 8 and 20 of the ‘183 Patent (Exhibit 1006) by replacing them with proposed substitute claims 22, 23 and 24, respectively.

74. I have reviewed all of the proposed substitute claims.

#### **The Myers ‘787 Patent**

75. In substitute claims 22 and 24, “The rotationally-mounted supports” (substitute claim 22) or the “at least one pair of wheels” (substitute claim 24) are “axially mounted transverse to the longitudinal axis ... to control the directional movement of said apparatus over the submerged surface”. The two brushes in Myers are mounted not horizontally, but at an angle that is acute to the vertical and not parallel to each other because Myers intends erratic movement. (Exhibit 1001, Col 2, Ins. 59 – 63 and FIG. 2) The ‘183 Patent is directed to a controlled movement cleaning apparatus. (See Exhibit 1006, col. 5, Ins. 4-9).

76. The resultant force vector, as recited in original claim 11 of the '183 Patent (Exhibit 1006), is not present in Myers because the mounting arrangement of Myers' brushes are not transverse to the longitudinal axis. Thus, the benefit of my invention is not and cannot be achieved by Myers.

**The Henkin '899 Patent and the Myers '787 Patent**

77. As previously discussed, neither Henkin nor Myers teach or suggest an apparatus with the “resultant force vector that is directed to a position that is proximate to and rearwardly displaced from a line passing through the transverse axial mountings of the front rotationally-mounted supports” (substituted claim 22) or the “front pair of wheels” (substituted claim 24).

78. As disclosed in the '183 Patent, the resultant force vector enables the apparatus to maintain consistent traction with the pool surface, advance the cleaner in a forward direction, and maintain proper orientation when contacting a vertical wall that is even normal to the horizontal bottom surface beneath the cleaner. Myers (Exhibit 1006), col. 10, ln. 60 – col. 11, ln. 3; col. 10, lns. 47 – 51; col. 25, lns. 10-13.

79. As stated earlier, a key to the utility of a controlled robotic pool cleaner is to move in a controlled direction and maintain its stability. In motorized robots, the stability is assisted by the vertical force of the pump to keep the apparatus in contact with the pool surface. Although relatively heavy out of the water, robotic

pool cleaners are designed to be of nearly neutral buoyancy under water with a minimal downward pressure created by the pump. If the angle of the pump discharge is altered for drive purposes, the stability will be lost when the apparatus comes into contact with a vertical surface normal to the horizontal bottom surface, unless the angle and direction, i.e., positioning of the resultant force vector  $V_r$  ensures that the apparatus does not flip over in the forward direction and disrupt the cleaning pattern. No one prior to the invention of the '183 Patent recognized this.

80. Henkin and Myers did not recognize the problem, yet alone try and solve it. These cleaners were directed only to using random movement to clean, while we were looking for the opposite – a stable, systematic, controlled pattern of movement to avoid twisting of the cable, as well as shorter cleaning operations to prevent excessive wear and tear on the cleaners and unnecessary waste of energy.

#### **The Pansini '641 Patent and the Myers "787 Patent**

81. Pansini does not recognize the problem or address the solution provided by the cleaner of the '183 Patent. Neither Pansini nor Myers suggest the resultant force vector that is directed to a position that is proximate to, and rearwardly displaced from a line passing through the transverse axial mountings of “the front rotationally-mounted supports” (substituted claim 22) or the “front pair of wheels” (substituted claim 24).

82. It is self-evident that Pansini never contemplated this force vector. The angle of the jet nozzle tubes 20 and 22 as shown in FIG. 3 of Pansini (Exhibit 1003) produces a resultant force vector that is directed forward of a line passing through the transverse axial mountings of the front pair of wheels. Similarly, any resultant force vector from Myers would be directed towards the upright/normally mounted brushes.

83. In 1999, it was not considered a viable alternative to use a jet drive as the principal propulsion force in robotic motor driven pool cleaners. Indeed, Zodiac, among others, warned against the use of electrical motors in submerged pool cleaners because of the inherent dangers of this combination.

84. I declare under the penalty of perjury that the foregoing is true and correct to the best of my knowledge and belief.

Dated: February 28, 2014



---

Giora Erlich

Filed on behalf of:

AQUA PRODUCTS, INC.

By:

Jeffrey A. Schwab Reg. No., Reg. No. 24,249  
Anthony A. Coppola, Reg. No. 41,493  
ABELMAN, FRAYNE & SCHWAB  
666 Third Avenue  
New York, New York 10017  
Tel: 212-949-9022  
Facsimile: 212-949-9190  
E-mail: [jaschwab@lawabel.com](mailto:jaschwab@lawabel.com),  
[aacoppola@lawabel.com](mailto:aacoppola@lawabel.com)  
(Atty. Docket No. 220,604)

UNITED STATES PATENT AND TRADEMARK OFFICE

---

BEFORE THE PATENT TRIAL AND APPEALBOARD

---

ZODIAC POOL SYSTEMS, INC.  
Petitioner

v.

AQUA PRODUCTS, INC.  
Patent Owner

---

Case IPR2013-00159  
Patent No. 8,273,183

---

Before BRIAN J. McNAMARA, RAMA G. ELLURU, and JAMES B. ARPIN

**PATENT OWNER AQUA PRODUCTS NOTICE OF APPEAL**

**A2911**

Director of the United States Patent and Trademark Office  
c/o Office of the General Counsel  
Madison Building East, 10B20  
600 Dulany Street  
Alexandria, VA 22314-5793

Pursuant to 35 U.S.C. § 141 and 37 C.F.R. § 90.2, Patent Owner, Aqua Products, Inc. (“Aqua Products”) hereby provides notice that it appeals to the United States Court of Appeals for the Federal Circuit from the Final Written Decision in IPR2013-00159, entered August 22, 2014 (Paper 71), and from all underlying orders, decisions, rulings, and opinions regarding Aqua Products U.S. Patent No. 8,273,183 (“the ‘183 patent”), including, without limitation, the Decision - Institution of *Inter Partes* Review entered on August 23, 2013 (Paper 18) and the Decision – Motion for Additional Discovery entered on October 18, 2013 (Paper 26).

In accordance with 37 C.F.R. § 90.2(a)(3)(ii), Aqua Products indicates that the issues on appeal include, but are not limited to, the Patent Trial and Appeal Board’s application and use of the broadest reasonable interpretation standard; claim construction; institution of *Inter Partes* Review of the ‘183 Patent; determination of unpatentability that claims 1, 2, 13, 14, 16, and 19-21 of the ‘183 patent are anticipated under 35 U.S.C. § 102(b) by U.S. Patent No. 3,321,787 by Myers (“Myers”); determination of unpatentability that claims 1-5 and 19-21 of the ‘183 patent are rendered obvious under 35 U.S.C. § 103(a) by U.S. Patent No.



3,936,899 by Henkin et al. (“Henkin”) and Myers; determination of unpatentability that claims 1-9 and 19-21 of the ’183 patent are rendered obvious under 35 U.S.C. § 103(a) by U.S. Patent No. 4,100,641 by Pansini (“Pansini”) and Myers; denial of Patent Owner’s Replacement Corrected Motion to Amend Claims; and any finding or determination supporting or relating to those issues, as well as all other issues decided adversely to Aqua Products in any order, decision, ruling, or opinion by the Patent Trial and Appeal Board in this Inter Partes Review Proceeding.

Pursuant to 35 U.S.C. § 142 and 37 C.F.R. § 90.2(a), this Notice is being filed with the Director of the United States Patent and Trademark Office, and a copy of this Notice is being concurrently filed with the Patent Trial and Appeal Board. In addition, three copies of this Notice along with the required docketing

//

//

//

fees are being filed with the Clerk's Office for the United States of Appeals for the Federal Circuit.

Respectfully submitted,

Date: October 23, 2014

By: /s/Jeffrey A. Schwab  
Jeffrey A. Schwab (Lead Counsel)  
Reg. No. 24,490  
Anthony A. Coppola  
Reg. No 41, 493  
Abelman, Frayne & Schwab  
666 Third Avenue  
New York, New York 10017  
Telephone: (212) 949-9022  
Facsimile: (212) 949-9190  
Email: jaschwab@lawabel.com  
Email: aacoppola@lawabel.com

Counsel for Patent Owner,  
Aqua Products, Inc.

**CERTIFICATE OF SERVICE AND FILING**

I hereby certify that on this 23rd day of October, 2014, the foregoing “PATENT OWNER AQUA PRODUCTS NOTICE OF APPEAL,” was filed with the Patent Trial and Appeal Board through the Board’s Patent Review Processing System, and true and correct copies thereof were filed and served as set forth below:

FILING BY OVERNIGHT FEDERAL EXPRESS

The Director of the United States Patent and Trademark Office, at the following address:

Director of the United States Patent and Trademark Office  
c/o Office of the General Counsel, 10B20  
Madison Building East  
600 Dulany Street  
Alexandria, Virginia

and

The Clerk’s Office of the United States Court of Appeals for the Federal Circuit (three true and correct copies), at the following address:

United States Court of Appeals for the Federal Circuit  
717 Madison Place, N.W., Suite 401  
Washington, DC 20005

SERVICE ELECTRONICALLY AND BY OVERNIGHT FEDERAL EXPRESS

I also hereby certify that on this 23<sup>rd</sup> day of October 2014, a true and correct copy of the foregoing “PATENT OWNER AQUA PRODUCTS NOTICE OF APPEAL,” was served, by electronic mail and overnight Federal Express Delivery, upon the following:

Christopher D. Bright  
Gregory D. Yoder  
McDermott Will & Emory LLP  
4 Park Plaza, Suite 1700  
Irvine, California 92614  
[cbright@mwe.com](mailto:cbright@mwe.com)  
[gyoder@mwe.com](mailto:gyoder@mwe.com)

Respectfully submitted,

October 23, 2014

/s/Jeffrey A. Schwab

### **CERTIFICATE OF SERVICE**

I certify that on July 24, 2015, this JOINT APPENDIX was filed electronically using the CM/ECF system and served via the CM/ECF system on counsel for the U.S. Patent and Trademark Office, as follows:

Nathan K. Kelley  
Farheena Rasheed  
Meredith Schoenfeld  
Scott C. Weidenfeller  
United States Patent and Trademark Office  
Office of the Solicitor  
P.O. Box 1450, Mail Stop 8  
Alexandria, VA 22313

/s/ John W. Kozikowski  
Litigation Legal Assistant  
Finnegan, Henderson, Farabow,  
Garrett & Dunner, LLP