

**UNITED STATES DISTRICT COURT  
SOUTHERN DISTRICT OF NEW YORK**

NEUROPUBLIC S.A.- Information Technologies

Plaintiff,

v.

LADAS & PARRY LLP,

Defendant.

Case No. 1:24-cv-4156

**COMPLAINT**

**Jury Trial Demanded**

**COMPLAINT**

Plaintiff, Neuropublic S.A. - Information Technologies (“Plaintiff” or “Neuropublic”), as and for its complaint against Defendant, Ladas & Parry LLP (“Defendant” or “Ladas & Parry”), states and alleges as follows:

**PARTIES**

1. Neuropublic S.A. - Information Technologies is a corporation organized under the laws of Greece, with a principal place of business located at Methoni str. 6, Piraeus, Post Code 18545. Neuropublic’s business is primarily focused in the areas of Informatics & Communications and Systems & Software Development Services.

2. Neuropublic owns the trade secrets and confidential information that are the subject of this action.

3. Ladas & Parry is a limited liability partnership organized under the laws of New York with a principal place of business located at 1040 Avenues of the Americas New York, NY 10018.

**JURISDICTION AND VENUE**

4. This Court has subject matter jurisdiction over this action.

5. This is an action for misappropriation of trade secrets and confidential information under the Defend Trade Secrets Act of 2016, 18 U.S.C. §§ 1831 *et seq.*, and for copyright infringement under the Copyright Act, 17 U.S.C. §§ 101 *et seq.* This Court has subject matter jurisdiction pursuant to 28 U.S.C. §§ 1331 and 1338. This Court has supplemental jurisdiction over the additional claims in this action for misappropriation of trade secrets, legal malpractice, and breach of fiduciary duty pursuant to 28 U.S.C. § 1367.

6. Venue is proper in this District pursuant to 28 U.S.C. § 1391 because the Defendant resides in this District, is registered as a limited liability partnership in this District, and the events that give rise to this action originated in this District. Venue is also proper in this District pursuant to 28 U.S.C. § 1400(b) because the Defendant has a regular and established place of business in this District.

7. The Court has personal jurisdiction over the Defendant because, among other things, Defendant resides and conducts business in this District, and the events that give rise to this action occurred in this District.

### **BACKGROUND**

8. Neuropublic is an innovative informatics and technology company founded in 2003 in Piraeus, Greece, specializing in developing cutting-edge technologies in geo-informatics and artificial intelligence.

9. At all relevant times, one integral part of Neuropublic's business is, and was, the proprietary telemeter station technology which Neuropublic described in the proposed invention disclosure (the "Proposed Invention Disclosure"). After entering into an attorney-client relationship with Ladas & Parry, Neuropublic provided this Proposed Invention Disclosure to Ladas & Parry in fall of 2020 on a confidential and privileged basis. In breach of its obligations

to Neuropublic, Ladas & Parry sent the entirety of the Proposed Invention Disclosure to a third-party, PatentManiac Consulting Private Limited (“PatentManiac”), without prior consent from, or notification to, Neuropublic, and without any indication to PatentManiac that the Proposed Invention Disclosure was Confidential, and was required to be treated confidentially.

10. Ladas & Parry is a law firm that provides legal services, including patent prosecution services, to clients and companies throughout the world. Ladas & Parry holds itself out as an expert in IP matters. On its website, Ladas & Parry asserts that: “Our expertise extends across all areas of intellectual property throughout the world.”

11. In addition to Ladas & Parry’s New York office, Ladas & Parry also has offices in Los Angeles, Chicago, Washington D.C., and London.

12. The growth and success of Neuropublic is, and was, in large part, due to its significant investment in inventing, developing, and protecting its innovative telemeter station technology, which is currently used in the agriculture industry, and which was embodied in the Proposed Invention Disclosure. The telemeter station technology makes real-time transmissions of relevant data collected from the field via the internet, including specifically atmospheric and soil parameters, permitting communication between the stations and other devices/platforms so that the data can be registered, analyzed, interpreted, and acted upon. For example, Neuropublic’s telemeter station technology can be used to predict expected crop efficiency, determine the amount that will be harvested under specific conditions, and identify crops and map them.

13. Neuropublic’s business model combines its proprietary technology with expertise in production and manufacturing, operations, risk management, and marketing, giving it control

over every step in the production process. Neuropublic provides this comprehensive suite of technologies and services by contract to customers, mainly in Europe.

14. Using its telemeter station technology, Neuropublic developed the first and only large-scale Internet of Things (“IoT”) infrastructure in Greece, installing thousands of sensors, which it designed and manufactured, on agricultural land.

15. Neuropublic restricted access to its telemeter station technology. Until 2023, when information concerning Neuropublic’s telemeter station technology was published as part of the patent application process (as more fully set forth below), all employees of Neuropublic who had access to the information contained within Neuropublic’s Proposed Invention Disclosure had duties of confidentiality to Neuropublic that required them to keep that information confidential. Neuropublic’s Proposed Invention Disclosure was stored on the personal computer belonging to the Director of Neuropublic’s IoT. This director was one of the inventors of Neuropublic’s telemeter station technology, and he was the only person with access to it. His password was required to be changed regularly. Upon information and belief, no other individual accessed Neuropublic’s Proposed Invention Disclosure aside from the Neuropublic’s Director of IoT, who then provided it to Neuropublic’s internal legal counsel and Neuropublic’s Chief Executive Officer (“CEO”).

16. Neuropublic’s Proposed Invention Disclosure has always been maintained in Greek, except that the final version was translated to English by the legal counsel retained by Neuropublic who provided the English version to Ladas & Parry. No other Neuropublic employees had access to the English translation of Neuropublic’s Proposed Invention Disclosure. Neuropublic’s Proposed Invention Disclosure has been otherwise confidentially maintained and protected in Greek.

17. Neuropublic has at all times taken reasonable measures to keep Neuropublic's telemeter station technology secret until the publication of its patent application number EP21210898.9 on May 31, 2023 as EP4186355 A1.

18. Neuropublic did not publish or otherwise publicly disclose the details of Neuropublic's telemeter station technology and/or Neuropublic's Proposed Invention Disclosure before May 31, 2023.

19. Neuropublic restricts access to key documents to a select few employees, limits visitor access to company facilities only to people who have appointments with specific employees of the company, and forbids the taking of photographs. With respect to Neuropublic's Proposed Invention Disclosure, access was even more limited.

20. On July 29, 2020, Neuropublic retained ARCHONTOULA PAPAPANAGIOTOU & ASSOCIATES based in Athens, 64 Skoufa Street, PC 10680 with registration number 80154 of the Athens Bar Association ("AP Law Firm") for counseling on patentability of its telemeter station technology, among other things.

21. On July 29, 2020, AP Law Firm requested from Neuropublic a complete description of Neuropublic's invention so that AP Law Firm could seek assistance from a U.S. law firm regarding the possibility of filing a patent application in the United States.

22. On August 7, 2020, an attorney from AP Law Firm emailed Ladas & Parry about a firm client (Neuropublic) interested in mapping and managing its IP portfolio and potentially filing for United States patent protection, and seeking legal counsel in the United States for those purposes. AP Law Firm requested information from Ladas & Parry about the costs and fees for assessing patentability and filing a patent application in the United States. AP Law Firm stated

that they were in possession of “a detailed draft with the description of the invention,” but that it was in Greek.

23. On August 31, 2020, Ladas & Parry responded to AP Law Firm with a schedule of charges for filing patent applications. The email also requested an English translation of Neuropublic’s Proposed Invention Disclosure and any information as to the state of the art, so that Ladas & Parry could provide its opinion as to the desirability of conducting a preliminary novelty search, the prospects for obtaining a patent that provides a reasonable scope of protection, and an estimate of Ladas & Parry’s likely charges for assisting in preparation of the patent application.

24. AP Law Firm, acting on behalf of Neuropublic, engaged Ladas & Parry to act as United States counsel for Neuropublic, for the purpose of assessing the patentability of the telemeter station technology, and potentially for the purpose of filing a patent application in the United States, based on the results of such assessment and potentially other factors.

25. On or about September 1, 2020, the AP Law Firm confirmed to Neuropublic that it had received Neuropublic's Proposed Invention Disclosure via a secure Virtual Data Room. Neuropublic’s secure Virtual Data Room was only accessible to certain legal professionals from the AP Law Firm.

26. Prior to loading Neuropublic’s Proposed Invention Disclosure to the Virtual Data Room, only Neuropublic’s Director of IoT, Neuropublic’s internal legal counsels, and Neuropublic’s CEO had access to Neuropublic’s Proposed Invention Disclosure.

27. On September 14, 2020, AP Law Firm sent the English translation of Neuropublic’s Proposed Invention Disclosure for the telemeter station technology to Neuropublic and requested their assistance with translating certain words from Greek to English.

28. On September 15, 2020, Neuropublic provided a revised version of the English translation to AP Law Firm, and agreed that it could be sent to Neuropublic's United States counsel, Ladas & Parry, so that Ladas & Parry could evaluate patentability in the United States.

29. On September 24, 2020, AP Law Firm added "CONFIDENTIAL" to the subject line of an email exchange with Ladas & Parry, and attached thereto the 21-page English translation of Neuropublic's Proposed Invention Disclosure. On behalf of Neuropublic, AP Law Firm requested that Ladas & Parry provide its legal opinion as to the next steps for their mutual client Neuropublic (hereinafter also the "Client").

30. On October 2, 2020, Ladas & Parry provided a preliminary review of Neuropublic's Proposed Invention Disclosure, noting that "[w]ith respect to the mast support system, we believe there may be subject matter that could be patented in a utility patent especially with respect to claims covering the mast support system with the components assembled thereon in designated positions that take advantage of their respective functions. In this respect, we would want further input as to how the positioning of each of the individual components improve their functions and, especially, as to how the soil multisensor unit fits into the mast support system."

31. On October 2, 2020, Ladas & Parry recommended that, before proceeding with a utility patent application, it should procure a preliminary novelty search. Ladas & Parry also requested additional technical information from the Client regarding specific aspects of the telemeter station technology invention. Ladas & Parry noted that the ornamental appearance of the mast support system could be patentable in a design patent application.

32. On October 6, 2020, on behalf of Neuropublic, AP Law Firm provided additional technical information and Neuropublic's answers to Ladas & Parry's questions.

33. On October 7, 2020, Ladas & Parry, based on the additional information received from the Client, recommended that the proposed patentability search also include another aspect of Neuropublic's telemeter station technology, the leaf multi-sensor.

34. On October 12, 2020, AP Law Firm informed Ladas & Parry that it could proceed with the preliminary novelty search for both the mast support system and the leaf multi-sensor contained in Neuropublic's Proposed Invention Disclosure as recommended by Ladas & Parry.

35. On October 16, 2020, Ladas & Parry informed AP Law Firm that it had initiated the preliminary novelty search.

36. Ladas & Parry did not seek Neuropublic's consent to hire a third party to conduct the preliminary novelty search. Ladas & Parry did not seek to notify Neuropublic that it would cause the search to be conducted by a third party outside the United States. Ladas & Parry did not seek to inform Neuropublic that it would send the entirety of the Proposed Invention Disclosure to any third party, nor did it seek consent to do so.

37. The same day, Ladas & Parry sent "Harry Jolly" from PatentManiac the 21-page English translation of Neuropublic's Proposed Invention Disclosure for its telemeter station technology, and requested an estimate for a preliminary novelty search directed "to the specific features discussed in section 1.7, which describes the construction of the mast support system, and section 1.3, which describes the leaf sensor. We want a search that is focused both on (a) the mast support system, as shown, which is constructed to be inserted into the soil and to stably accommodate a plurality of different sensors and processors with a small footprint and in desired orientation to the crops being measured, and (b) a leaf sensor that is capable of sensing a combination of different parameters, including leaf temperature, leaf humidity and leaf moisture,



and which is designed for disposition on the mast support at a desired angle relative to the leaves of a crop.”

38. On information and belief, PatentManiac is headquartered in New Delhi, India with only a P.O. Box located in the United States. According to its website, PatentManiac provides cost-effective and quality solutions in a timely manner to Attorneys, Law/IP Firms, Corporations, Legal Departments, Patent Brokerage Firms, in-house counsels, and individual inventors.

39. Upon information and belief, Ladas & Parry did not obtain a confidentiality, non-disclosure, service, or retainer agreement with PatentManiac before it provided the entirety of Neuropublic’s Proposed Invention Disclosure to PatentManiac. Upon information and belief, Ladas & Parry never obtained such an agreement with PatentManiac with respect to Neuropublic’s Proposed Invention Disclosure.

40. Ladas & Parry sent the entirety of the English translation of Neuropublic’s Proposed Invention Disclosure to PatentManiac without marking the document or email confidential. There were no instructions within Ladas & Parry’s email attaching Neuropublic’s Proposed Invention Disclosure that identified the document or the email as confidential, or that requested assurances the information would not be used or disclosed to others. There were no instructions to restrict access to the Proposed Invention Disclosure only to the individuals performing the search. There were also no instructions to destroy the material once the search was complete.

41. Upon information and belief, Ladas & Parry’s communications with PatentManiac were exclusively through email correspondence, and Ladas & Parry never

informed PatentManiac, in any of its communications, of the confidential nature of Neuropublic's Proposed Invention Disclosure.

42. On October 27, 2020, PatentManiac sent Ladas & Parry a document titled Patentability Search Report dated October 22, 2020. According to the Patentability Search Report dated October 22, 2020, the patentability search was conducted by a research associate at PatentManiac.

43. On October 28, 2020, Ladas & Parry sent the Patentability Search Report dated October 22, 2020 to AP Law Firm and requested that the Client review the report and provide Ladas & Parry with comments. Ladas & Parry further stated that they would study the report and provide their analysis and recommendations after receiving Neuropublic's comments.

44. On November 9, 2020, Neuropublic requested the final English translation of its Proposed Invention Disclosure that AP Law Firm had sent to Ladas & Parry so that Neuropublic could make any comment and additions, if necessary.

45. On December 9, 2020, after receiving comments from Neuropublic, Ladas & Parry provided a summary of patentability for Neuropublic and noted the possibility of obtaining patent protection on their telemeter station technology was good.

46. On May 31, 2021, AP Law Firm informed Ladas & Parry that Neuropublic decided not to proceed with filing of a patent on its telemeter station technology in the United States.

47. On June 8, 2021, Ladas & Parry acknowledged receipt by email to AP Law Firm and referenced a copy of the final debit note to close out the billing on the matter.

48. Neuropublic filed a European patent application on its telemeter station technology, EP21210898.9, with the European Patent Office ("EPO") on November 26, 2021.

This document remained unavailable to the public until it was published by the EPO on May 31, 2023.

49. As part of its examination of Neuropublic’s patent application, the EPO identified Australian Patent Application Publication No. AU2021102664A4 (“AU2021102664A4”) by Search Report dated April 25, 2022 as a document it considered relevant to Neuropublic’s EP21210898.9.

50. After learning of its existence from the EPO, Neuropublic investigated AU2021102664A4 and determined that it was nearly identical to Neuropublic’s Proposed Invention Disclosure for its telemeter station technology that it provided to Ladas & Parry, via AP Law Firm, in September 2020.

51. AU2021102664A4, titled “Plant and Soil Attribute Monitoring Station,” was filed with the Australia Government on May 18, 2021, identifying Ankush Gosh and Milan Kumar as applicants and co-inventors. Rabindra Nath Shaw, Koushik Majumder, and Baishali Ghosal were also identified as co-inventors.

52. On April 26, 2024, the EPO sent correspondence related to Neuropublic’s pending application and identified AU2021102664A4 stating, among other things, that “it appears that the present application does not meet the requirements of Article 52(1) EPC because the subject matter of claim 1 is not new...” The EPO then describes the similarities between AU2021102664A4 and Neuropublic’s pending claims. AU2021102664A4 remains an obstacle to the patentability of Neuropublic’s invention.

53. The Australia Patents Act 1990 Statement of Entitlement for AU2021102664A4 was filed by IPQuad Partners. The Cover Sheet for the Patent New Application Innovation for AU2021102664A4 shows that it was also requested by IPQuad Partners.

54. On information and belief, IPQuad Partners has its registered office in New Delhi, India and, according to its website, is an Indian IP research and analytical service firm with a full range of IP services.

55. Upon information and belief, IPQuad Partners' owner and co-founder was employed by PatentManiac for several years until September 2019.

56. Upon information and belief, Neuropublic's Proposed Invention Disclosure that Neuropublic sent to Ladas & Parry, on a confidential and attorney-client privileged basis, and which Ladas & Parry sent to PatentManiac in October 2020, formed the basis of AU2021102664A4.

57. Material portions of AU2021102664A4 are the same or substantially the same as the corresponding portions of the English translation of Neuropublic's Proposed Invention Disclosure provided to PatentManiac by Ladas & Parry.

58. As shown below, certain depictions of the system and components thereof are also identical or nearly identical:

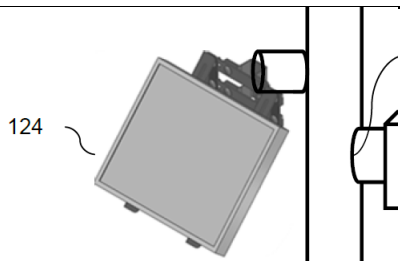
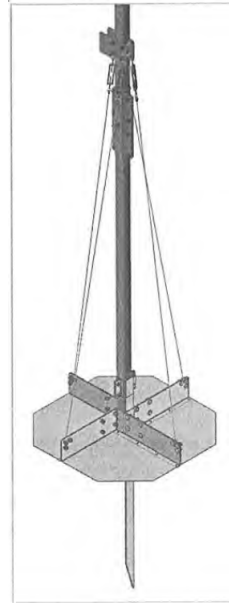
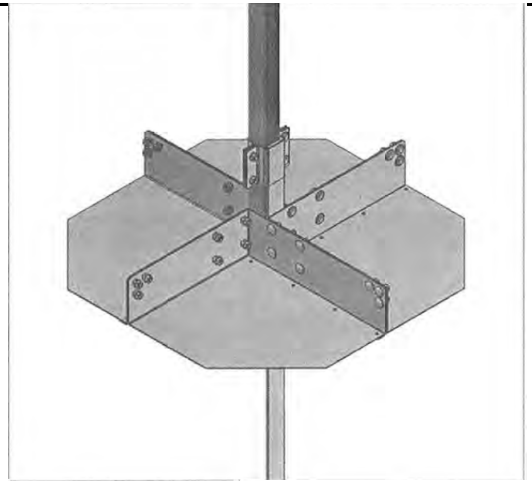
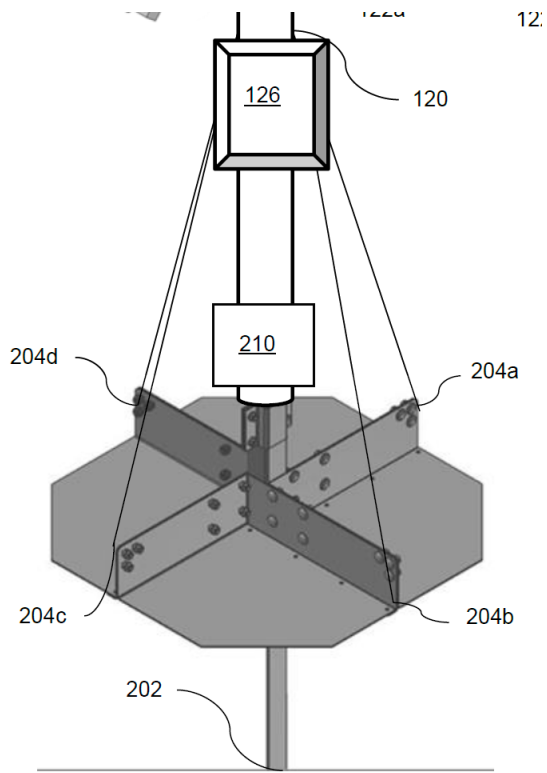

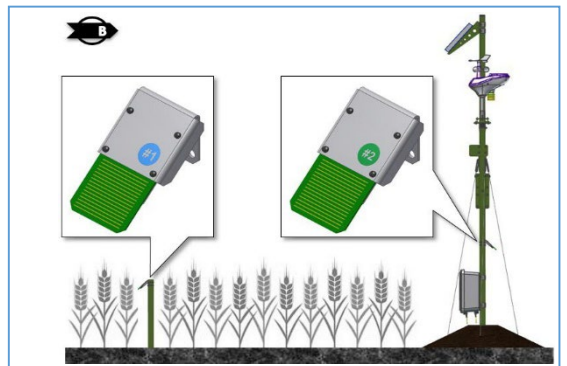
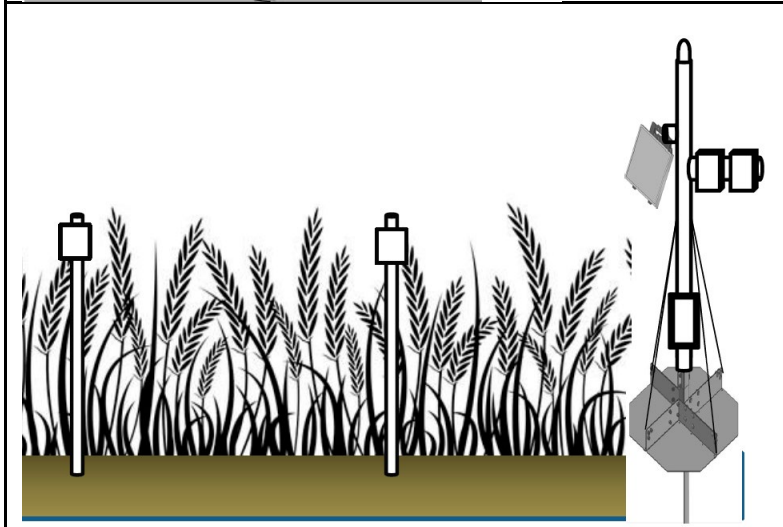
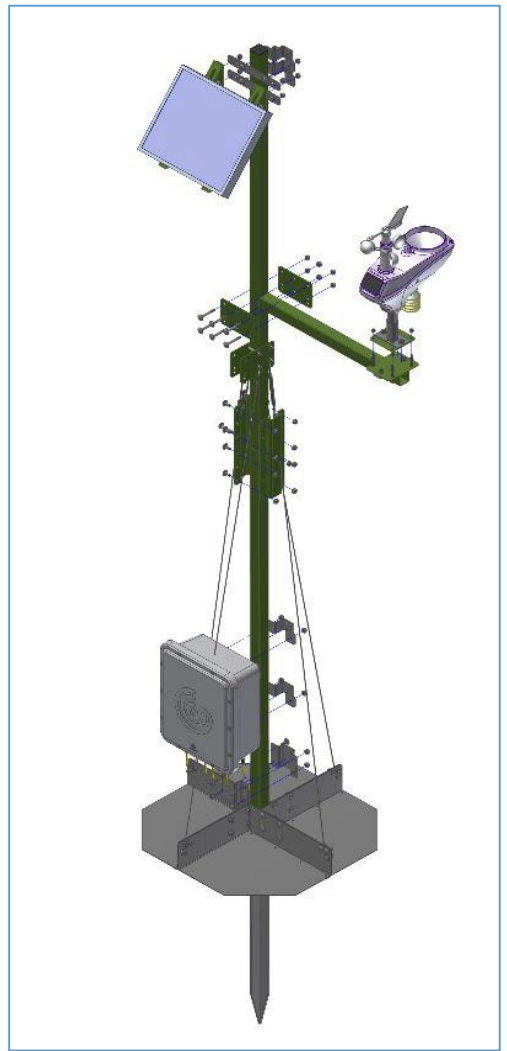
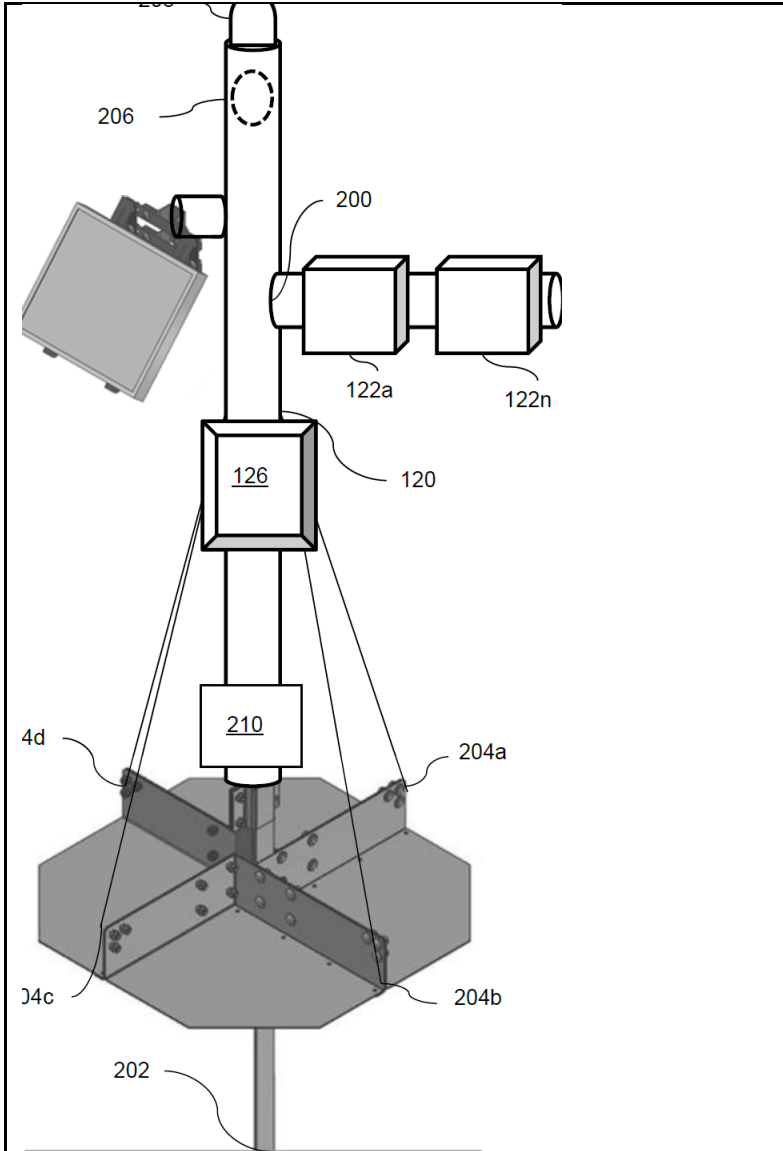

**COUNT I**  
**Misappropriation of Neuropublic's Trade Secrets**  
**Defend Trade Secrets Act (18 U.S.C. § 1831, et seq.)**

59. Plaintiff realleges and incorporates by reference the allegations of Paragraphs 1 through 58 above as though fully set forth herein.

60. Neuropublic is the owner of valuable trade secret information that was reflected in Neuropublic's non-public Proposed Invention Disclosure relating to its telemeter station invention.

61. Neuropublic has taken reasonable measures to keep its trade secret information confidential.

62. Neuropublic's trade secret derived independent economic value, actual and potential, from not being generally known to, and not being readily ascertainable through proper means by, another person who can obtain economic value from the disclosure or use of the information.

63. Neuropublic's trade secret information was disclosed to Defendant Ladas & Parry as part of a confidential attorney-client relationship. Thus, the disclosure was made under circumstances giving rise to a duty to maintain the secrecy of the trade secret.

64. Defendant Ladas & Parry disclosed the entirety of Neuropublic's trade secret information to a third party, PatentManiac, without (a) informing Neuropublic that it intended to disclose the entirety of Neuropublic's Proposed Invention Disclosure to PatentManiac; (b) obtaining consent from Neuropublic to disclose the entirety of Neuropublic's invention disclose to PatentManiac; or (c) putting any restrictions in place with respect to PatentManiac via nondisclosure agreement or any other means.

65. Neuropublic's trade secret information is related to a product or service used in and intended for use in interstate or foreign commerce.

66. As a result of the misappropriation alleged herein, Plaintiff has been damaged in an amount to be determined at trial.

**COUNT II**  
**Copyright Infringement Under the United States Copyright Act**  
**17 U.S.C. Sections 101 *et seq.* (the "Copyright Act")**

67. Plaintiff realleges and incorporates by reference the allegations of Paragraphs 1 through 66 above as though fully set forth herein.

68. Neuropublic's Proposed Invention Disclosure relating to its telemeter station invention is a work made for hire that was prepared by employees within the scope of their employment with Neuropublic.

69. Neuropublic is and at all times has been the owner of the copyright in the Proposed Invention Disclosure.

70. Neuropublic's Proposed Invention Disclosure was sent to Defendant Ladas & Parry as part of a confidential attorney-client relationship. Thus, the disclosure was made under circumstances giving rise to a duty to maintain the secrecy of the Proposed Invention Disclosure.

71. Ladas & Parry wrongfully exported the Proposed Invention Disclosure from the United States without the authority of Neuropublic.

72. Ladas & Parry's wrongful exportation of the Proposed Invention Disclosure from the United States without the authority of Neuropublic infringed upon Neuropublic's exclusive right to distribute copies of the Proposed Invention Disclosure.

73. As a result of the copyright infringement alleged herein, Plaintiff has been damaged in an amount to be determined at trial.



**COUNT III**  
**Misappropriation of Neuropublic's Trade Secret**  
**New York State Law**

74. Plaintiff realleges and incorporates by reference the allegations of Paragraphs 1 through 73 above as though fully set forth herein.

75. Neuropublic is the owner of valuable trade secret information that was reflected in Neuropublic's non-public Proposed Invention Disclosure relating to its telemeter station invention.

76. Neuropublic has taken reasonable measures to keep its trade secret information confidential.

77. Neuropublic's trade secret derived independent economic value, actual and potential, from not being generally known to, and not being readily ascertainable through proper means by, another person who can obtain economic value from the disclosure or use of the information.

78. Neuropublic's trade secret information was disclosed to Defendant Ladas & Parry as part of a confidential attorney-client relationship. Thus, the disclosure was made under circumstances giving rise to a duty to maintain the secrecy of the trade secret.

79. Defendant Ladas & Parry wrongfully used the entirety of Neuropublic's trade secret information by disclosing it to a third party, PatentManiac, without (a) informing Neuropublic that it intended to disclose the entirety of Neuropublic's Proposed Invention Disclosure to PatentManiac; (b) consent from Neuropublic to disclose the entirety of Neuropublic's Invention Disclosure to PatentManiac; or (c) putting any restrictions in place with respect to Patent Maniac via nondisclosure agreement or any other means.

80. As a result of the misappropriation alleged herein, Plaintiff has been damaged in an amount to be determined at trial.

**COUNT IV**  
**Legal Malpractice**

81. Plaintiff realleges and incorporates by reference the allegations of Paragraphs 1 through 80 above as though fully set forth herein.

82. Ladas & Parry entered into an attorney-client relationship with Neuropublic. Specifically, Neuropublic engaged Ladas & Parry, via AP Law Firm, to perform legal services with respect to its consideration of patent protection in the United States with respect to Neuropublic's telemeter station invention.

83. By virtue of this relationship, Ladas & Parry owed a duty to Neuropublic to adequately and properly represent its interest, and to meet the applicable standard of care attendant to its representation.

84. Ladas & Parry departed from the standard of care, skill, and diligence expected by a member of the legal community by at least (1) sending Neuropublic's entire Proposed Invention Disclosure to a third-party firm, PatentManiac; (2) doing so without any written confidentiality or non-disclosure agreements or obligations between Ladas & Parry (or Neuropublic) and PatentManiac; and (3) failing to mark Neuropublic's Proposed Invention Disclosure as confidential or referencing confidentiality in its cover email to PatentManiac.

85. Ladas & Parry's negligence caused harm to Neuropublic. After Ladas & Parry sent Neuropublic's Proposed Invention Disclosure to PatentManiac, a former PatentManiac associate filed a suspiciously similar patent application in Australia. The Australian patent application contains similarities to Neuropublic's Invention Disclosure, including at least some

identical language, identical dimensions and specifications, and nearly identical figures. These similarities are too numerous and specific to be the result of coincidence.

86. Neuropublic has been harmed in numerous ways, including at least: (1) that its trade secret and confidential Proposed Invention Disclosure was published to the entire world without Neuropublic's knowledge or consent; (2) that its trade secret and confidential Proposed Invention Disclosure has become prior art to Neuropublic's own patent filings and has already been identified as prior art in the European Patent Office against Neuropublic's pending patent application; and (3) Neuropublic is likely unable to obtain patent coverage in at least Australia.

87. Neuropublic has suffered actual damages as a result of Ladas & Parry's malpractice in an amount to be determined at trial.

**COUNT V**  
**Breach of Fiduciary Duty**

88. Plaintiff realleges and incorporates by reference the allegations of Paragraphs 1 through 87 above as though fully set forth herein.

89. Defendant Ladas & Parry, in connection with its attorney-client relationship with Neuropublic, had a fiduciary duty to Neuropublic to act in Neuropublic's best interest. This fiduciary duty included, at minimum, maintaining Neuropublic's confidentiality and safeguarding Neuropublic's property.

90. Ladas & Parry breached its fiduciary duty at least by: (1) sending Neuropublic's entire Proposed Invention Disclosure to a third-party firm, PatentManiac; (2) doing so without securing any written confidentiality or non-disclosure agreements between Ladas & Parry (or Neuropublic) and PatentManiac; and (3) failing to mark Neuropublic's Proposed Invention Disclosure as confidential or referencing confidentiality in its cover email to PatentManiac.

91. Neuropublic has been harmed by Defendant's breach of its fiduciary duty in numerous ways, including at least: (1) that its trade secret and confidential Proposed Invention Disclosure was published to the entire world without Neuropublic's knowledge or consent; (2) that its trade secret and confidential Proposed Invention Disclosure has become prior art to Neuropublic's own patent filings and has already been identified as prior art in the European Patent Office against Neuropublic's pending patent application; and (3) Neuropublic is likely unable to obtain patent coverage in at least Australia.

92. Neuropublic has suffered actual damages as a result of Ladas & Parry's breach of fiduciary duty in an amount to be determined at trial.

#### **PRAYER FOR RELIEF**

WHEREFORE, Plaintiff demands judgment against Defendant as follows:

A. Permanent injunctive relief barring Defendant from using or disclosing Plaintiff's trade secret information;

B. On its First Claim for Relief, awarding Plaintiff damages in an amount to be determined at trial;

C. On its Second Claim for Relief, awarding Plaintiff damages in an amount to be determined at trial;

D. On its Third Claim for Relief, awarding Plaintiff damages in an amount to be determined at trial;

E. On its Fourth Claim for Relief, awarding Plaintiff damages in an amount to be determined at trial;

F. On its Fifth Claim for Relief, awarding Plaintiff damages in an amount to be determined at trial;

G. Awarding Plaintiff pre-judgment and post-judgment interest in the maximum allowed permitted by law;

H. Awarding Plaintiff the cost of this action, and its reasonable disbursements and attorney' fees; and

L. Such other and further relief as this Court deems just and equitable.

**DEMAND FOR JURY TRIAL**

Plaintiff hereby requests a trial by jury on all issues of fact and damages stated herein.

Dated: May 30, 2024

Respectfully submitted,

**WITHERS BERGMAN LLP**

By: \_\_\_\_\_

  
Joseph P. Gallo  
Christopher N. LaVigne  
Chaya Weinberg-Brodt

430 Park Avenue  
New York, New York 10022  
[Joseph.Gallo@Withersworldwide.com](mailto:Joseph.Gallo@Withersworldwide.com)  
[Christopher.LaVigne@Withersworldwide.com](mailto:Christopher.LaVigne@Withersworldwide.com)

*Counsel for Plaintiff*