

United States Court of Appeals for the Federal Circuit

03-1269, -1286

EDWARD H. PHILLIPS,

Plaintiff-Appellant,

v.

AWH CORPORATION,
HOPEMAN BROTHERS, INC., and LOFTON CORPORATION,

Defendants-Cross Appellants.

Carl F. Manthei, Attorney at Law, of Boulder, Colorado, argued for plaintiff-appellant.

Mark W. Fischer, Faegre & Benson LLP, of Boulder, Colorado, argued for defendants-cross appellants. With him on the brief were Neal S. Cohen and Peter J. Kinsella. Of counsel on the brief were Maurice M. Klee, Law Office of Maurice M. Klee, Ph.D., Fairfield, Connecticut, and Kenneth C. Bass, III, Sterne, Kessler, Goldstein & Fox, of Washington, DC. Of counsel was Scott E. Holwick, Faegre & Benson LLP.

John M. Whealan, Solicitor, United States Patent and Trademark Office, of Alexandria, Virginia, argued for amicus curiae United States. With him on the brief were James A. Toupin, General Counsel; Cynthia C. Lynch; Linda Moncys Isacson; and Thomas W. Krause, Associate Solicitors. Of counsel on the brief were Peter D. Keisler, Assistant Attorney General; John J. Fargo, Director, Commercial Litigation Branch, and Anthony J. Steinmeyer, Attorney, Appellate Staff, Civil Division, United States Department of Justice, of Washington, DC; and William E. Kovacic, General Counsel, and Suzanne T. Michel, Chief Counsel for Intellectual Property, Federal Trade Commission, of Washington, DC.

Robert L. Baechtold, Fitzpatrick, Cella, Harper & Scinto, of New York, New York, for amici curiae Novartis Pharmaceuticals Corporation, et al. With him on the brief were Nicholas N. Kallas, Stevan J. Bosses, and Brian V. Slater.

Paul H. Berghoff, McDonnell Boehnen Hulbert & Berghoff LLP, of Chicago, Illinois, for amicus curiae Intellectual Property Owners Association. With him on the brief was Joshua R. Rich. Of counsel on the brief was J. Jeffery Hawley, President, Intellectual Property Owners Association, of Washington, DC. Of counsel was Herbert C. Wamsley, Intellectual Property Owners Association.

Charles W. Bradley, Rader, Fishman & Grauer, PLLC, of Bloomfield Hills, Michigan, for amicus curiae Charles W. Bradley.

Henry C. Bunsow, Howrey Simon Arnold & White, LLP, of San Francisco, California, for amicus curiae AD HOC Committee of Patent Owners in the Wireless Industry. With him on the brief were Robert C. Laurenson and David W. Long. Of counsel on the brief were Robert D. Yeager, Thomas J. Edgington, and Mark G. Knedeisen, Kirkpatrick & Lockhart LLP, of Pittsburgh, Pennsylvania.

Alexander C. Johnson, Jr., Marger, Johnson & McCollom, P.C., of Portland, Oregon, for amicus curiae Oregon Patent Law Association.

Alice A. Kipel, Steptoe & Johnson, LLP, of Washington, DC, for amicus curiae International Trade Commission Trial Lawyers Association.

Stephen P. McNamara, St. Onge Steward Johnston & Reens LLC, of Stamford, Connecticut, for amicus curiae Connecticut Intellectual Property Law Association. With him on the brief was Richard J. Basile. Of counsel on the brief were William J. Sapone, Coleman Sudol Sapone, P.C., of Bridgeport, Connecticut, Michael J. Rye, Cantor Colburn LLP, of Bloomfield, Connecticut.

Douglas E. Olson, Paul, Hastings, Janofsky & Walker, LLP, of San Diego, California, for amicus curiae San Diego Intellectual Property Law Association. With him on the brief were Kurt M. Kjelland, John E. Peterson, and April M. Alex. Of counsel on the brief were Ned A. Israelsen, Knobbe Martens Olson & Bear, LLP, of San Diego, California, and William L. Respass, Nanogen, Inc., of San Diego, California.

John Will Ongman, Barnes & Thornburg LLP, of Washington, DC, for amicus curiae Biotechnology Industry Organization. With him on the brief was Alice O. Martin, of Chicago, Illinois. Of counsel on the brief was Stephan E. Lawton, Vice President and General Counsel, Biotechnology Industry Organization, of Washington, DC.

Steve Z. Szczepanski, Kelley Drye & Warren LLP, of Chicago, Illinois, for amicus curiae Parus Holdings, Inc. With him on the brief was Mary Jo Boldingh.

Frederick A. Tecce, McShea Tecce, P.C., of Philadelphia, Pennsylvania, for amici curiae McShea Tecce, P.C., et al.

Michael P. Dougherty, Morgan & Finnegan, L.L.P., of New York, New York, for amicus curiae Federal Circuit Bar Association. Of counsel on the brief was Charles F. Schill, President, Federal Circuit Bar Association, of Washington, DC.

Edward D. Manzo, Cook, Alex, McFarron, Manzo, Cummings & Mehler, Ltd., of Chicago, Illinois, for amicus curiae The Intellectual Property Law Association of Chicago. Of counsel with him on the brief were Patrick G. Burns, Greer, Burns & Crain, Ltd., of Chicago, Illinois, Dean A. Monco, Wood, Phillips, Katz, Clark & Mortimer, of Chicago, Illinois, Bradford

P. Lyerla, Marshall, Gerstein & Borun, of Chicago, Illinois, and Timothy J. Vezeau, Katten Muchin Zavis Rosenman, of Chicago, Illinois.

Maxim H. Waldbaum, Schiff Hardin LLP, of New York, New York, for amicus curiae Federation Internationale Des Conseils En Propriete Industrielle. Of counsel on the brief was John P. Sutton, of San Francisco, California.

Michael R. Dzwonczyk, Sughrue Mion, PLLC, of Washington, DC, for amicus curiae Sughrue Mion, PLLC. With him on the brief were Frank L. Bernstein of Mountain View, California, and Brandon M. White of Washington, DC.

Sharon A. Israel, Jenkins & Gilchrist, P.C., of Houston, Texas, for amicus curiae Houston Intellectual Property Law Association. Of counsel on the brief were Jeremy P. Welch, Jonathan M. Pierce, and Jeffrey L. Johnson, Conley Rose, P.C., of Houston, Texas.

George C. Summerfield, Jr., Stadheim & Gear, of Chicago, Illinois, for amici curiae The Wisconsin Alumni Research Foundation, et al. With him on the brief were Joseph A. Gear and Keith A. Vogt.

Bruce M. Wexler, Fitzpatrick, Cella, Harper & Scinto, of New York, New York, for amicus curiae New York Intellectual Property Law Association. With him on the brief were Matthew S. Seidner and John D. Murnane.

Rick D. Nydegger, Workman Nydegger, of Salt Lake City, Utah, for amicus curiae American Intellectual Property Law Association. With him on the brief was David R. Todd. Of counsel on the brief were Denise W. DeFranco, Foley Hoag LLP, of Boston, Massachusetts, and Joseph R. Re and Joseph S. Cianfrani, Knobbe Martens Olson & Bear, of Irvine, California.

Christopher Landau, Kirkland & Ellis LLP, of Washington, DC, for amicus curiae Infineon Technologies North America Corp. With him on the brief were John C. O'Quinn, of Washington, DC, and John M. Desmarais, Gregory S. Arovas, and Michael P. Stadnick, of New York, New York.

Mark I. Levy, Kilpatrick Stockton, LLP, of Washington, DC, for amicus curiae Association of Corporate Counsel. With him on the brief were Anthony B. Askew and Eugene B. Joswick, of Atlanta, Georgia. Of counsel on the brief were Frederick J. Krebs and Susan Hackett of Washington, DC, Nelson A. Blish, Eastman Kodak, of Rochester, New York, John W. Hogan, Jr., Wyeth, of Madison, New Jersey, and Taraneh Maghame, Hewlett Packard, of Cupertino, California.

Mark A. Lemley, Kecker & VanNest, LLP, of San Francisco, California, for amici curiae Intel Corporation, et al. With him on the brief were Brian L. Ferrall and Ryan M. Kent.

Erik Paul Belt, Bromberg and Sunstein LLP, of Boston, Massachusetts, for amicus curiae Boston Patent Law Association. Of counsel on the brief was Peter Corless, Edwards and Angell LLP, of Boston, Massachusetts.

Susan M. Dadio, Burns, Doane, Swecker & Mathis, L.L.P., of Alexandria, Virginia, for amicus curiae Bar Association of the District of Columbia – Patent, Trademark & Copyright Section. Of counsel on the brief was Lynn E. Eccleston, The Eccleston Law Firm, of Washington, DC.

W. Thomas McGough, Jr., Reed Smith LLP, of Pittsburgh, Pennsylvania, for amicus curiae Medrad, Inc. With him on the brief were Frederick H. Colen and Barry J. Coyne. Of counsel on the brief was Gregory L. Bradley, Medrad, Inc., of Indianola, Pennsylvania.

Peter A. Sullivan, Hughes Hubbard & Reed LLP, of New York, New York, for amicus curiae The Association of the Bar of the City of New York. Of counsel on the brief was Catriona M. Collins, Cowan, Liebowitz & Latman, P.C., of New York, New York.

Anthony R. Zeuli, Merchant & Gould P.C., of Minneapolis, Minnesota, for amicus curiae Association of Patent Law Firms. With him on the brief were Thomas J. Leach, III and Rachel Clark-Hughey. Of counsel on the brief were Scott P. McBride and Christopher R. Carroll, McAndrews, Held & Malloy Ltd., of Chicago, Illinois, and Eric R. Moran, McDonnell, Boehnen, Hulbert & Berghoff LLP, of Chicago, Illinois.

Daniel B. Ravicher, Public Patent Foundation, of New York, New York, for amicus curiae Public Patent Foundation.

Theodore T. Herhold, Townsend and Townsend and Crew LLP, of Palo Alto, California, for amici curiae VISA U.S.A. Inc., et al. With him on the brief were Daniel J. Furniss, Susan M. Spaeth, Madison C. Jellins, and Mark G. Sandbaken.

Mark A. Goldstein, SoCal IP Law Group, of Westlake Village, California, for amicus curiae Conejo Valley Bar Association. With him on the brief were Steven C. Sereboff and Joel G. Landau.

Robert J. Grey, Jr., President, American Bar Association, of Chicago, Illinois, for amicus curiae American Bar Association. With him on the brief was William L. LaFuze. Of counsel on the brief were Donald R. Dunner and Richard L. Rainey, Finnegan, Henderson, Farabow, Garrett & Dunner, L.L.P., of Washington, DC.

R. Polk Wagner, University of Pennsylvania Law School, of Philadelphia, Pennsylvania, for amicus curiae Patent Law Professors R. Polk Wagner, et al.

Joshua D. Sarnoff, Washington College of Law, American University, of Washington, DC, for amici curiae Consumers Union, et al.

Laura M. Slenzak, Siemens Corporation, of Auburn Hills, Michigan, for amicus curiae The State Bar of Michigan, Intellectual Property Law Section, joined in the brief of the New York Intellectual Property Law Association.

Lea Hall Speed, Baker, Donelson, Bearman & Caldwell, of Memphis, Tennessee, for amicus curiae Tennessee Bar Association, joined in the brief of the New York Intellectual Property Law Association.

Appealed from: United States District Court for the District of Colorado

Judge Marcia S. Krieger

United States Court of Appeals for the Federal Circuit

03-1269, -1286

EDWARD H. PHILLIPS,

Plaintiff-Appellant,

v.

AWH CORPORATION,
HOPEMAN BROTHERS, INC., and LOFTON CORPORATION,

Defendants-Cross Appellants.

DECIDED: July 12, 2005

Before MICHEL, Chief Judge, NEWMAN, MAYER, LOURIE, CLEVINGER, RADER, SCHALL, BRYSON, GAJARSA, LINN, DYK, and PROST, Circuit Judges.

Opinion for the court filed by Circuit Judge BRYSON, in which Chief Judge MICHEL and Circuit Judges CLEVINGER, RADER, SCHALL, GAJARSA, LINN, DYK, and PROST join; and in which Circuit Judge LOURIE joins with respect to parts I, II, III, V, and VI; and in which Circuit Judge NEWMAN joins with respect to parts I, II, III, and V. Opinion concurring in part and dissenting in part filed by Circuit Judge LOURIE, in which Circuit Judge NEWMAN joins. Dissenting opinion filed by Circuit Judge MAYER, in which Circuit Judge NEWMAN joins.

BRYSON, Circuit Judge.

Edward H. Phillips invented modular, steel-shell panels that can be welded together to form vandalism-resistant walls. The panels are especially useful in building prisons because they are load-bearing and impact-resistant, while also insulating against fire and noise. Mr. Phillips obtained a patent on the invention, U.S. Patent No. 4,677,798 (“the ’798 patent”), and he subsequently entered into an arrangement with

AWH Corporation, Hopeman Brothers, Inc., and Lofton Corporation (collectively “AWH”) to market and sell the panels. That arrangement ended in 1990. In 1991, however, Mr. Phillips received a sales brochure from AWH that suggested to him that AWH was continuing to use his trade secrets and patented technology without his consent. In a series of letters in 1991 and 1992, Mr. Phillips accused AWH of patent infringement and trade secret misappropriation. Correspondence between the parties regarding the matter ceased after that time.

In February 1997, Mr. Phillips brought suit in the United States District Court for the District of Colorado charging AWH with misappropriation of trade secrets and infringement of claims 1, 21, 22, 24, 25, and 26 of the '798 patent. Phillips v. AWH Corp., No. 97-N-212 (D. Colo.). The district court dismissed the trade secret misappropriation claim as barred by Colorado’s three-year statute of limitations.

With regard to the patent infringement issue, the district court focused on the language of claim 1, which recites “further means disposed inside the shell for increasing its load bearing capacity comprising internal steel baffles extending inwardly from the steel shell walls.” The court interpreted that language as “a means . . . for performing a specified function,” subject to 35 U.S.C. § 112, paragraph 6, which provides that such a claim “shall be construed to cover the corresponding structure, material, or acts described in the specification and equivalents thereof.” Looking to the specification of the '798 patent, the court noted that “every textual reference in the Specification and its diagrams show baffle deployment at an angle other than 90° to the wall faces” and that “placement of the baffles at such angles creates an intermediate interlocking, but not solid, internal barrier.” The district court therefore ruled that, for

purposes of the '798 patent, a baffle must “extend inward from the steel shell walls at an oblique or acute angle to the wall face” and must form part of an interlocking barrier in the interior of the wall module. Because Mr. Phillips could not prove infringement under that claim construction, the district court granted summary judgment of noninfringement.

Mr. Phillips appealed with respect to both the trade secret and patent infringement claims. A panel of this court affirmed on both issues. Phillips v. AWH Corp., 363 F.3d 1207 (Fed. Cir. 2004). As to the trade secret claim, the panel unanimously upheld the district court’s ruling that the claim was barred by the applicable statute of limitations. Id. at 1215. As to the patent infringement claims, the panel was divided. The majority sustained the district court’s summary judgment of noninfringement, although on different grounds. The dissenting judge would have reversed the summary judgment of noninfringement.

The panel first determined that because the asserted claims of the '798 patent contain a sufficient recitation of structure, the district court erred by construing the term “baffles” to invoke the “means-plus-function” claim format authorized by section 112, paragraph 6. Id. at 1212. Nonetheless, the panel concluded that the patent uses the term “baffles” in a restrictive manner. Based on the patent’s written description, the panel held that the claim term “baffles” excludes structures that extend at a 90 degree angle from the walls. The panel noted that the specification repeatedly refers to the ability of the claimed baffles to deflect projectiles and that it describes the baffles as being “disposed at such angles that bullets which might penetrate the outer steel panels are deflected.” '798 patent, col. 2, ll. 13-15; see also id. at col. 5, ll. 17-19 (baffles are “disposed at angles which tend to deflect the bullets”). In addition, the panel observed

that nowhere in the patent is there any disclosure of a baffle projecting from the wall at a right angle and that baffles oriented at 90 degrees to the wall were found in the prior art. Based on “the specification’s explicit descriptions,” the panel concluded “that the patentee regarded his invention as panels providing impact or projectile resistance and that the baffles must be oriented at angles other than 90°.” Phillips, 363 F.3d at 1213. The panel added that the patent specification “is intended to support and inform the claims, and here it makes it unmistakably clear that the invention involves baffles angled at other than 90°.” Id. at 1214. The panel therefore upheld the district court’s summary judgment of noninfringement.

The dissenting judge argued that the panel had improperly limited the claims to the particular embodiment of the invention disclosed in the specification, rather than adopting the “plain meaning” of the term “baffles.” The dissenting judge noted that the parties had stipulated that “baffles” are a “means for obstructing, impeding, or checking the flow of something,” and that the panel majority had agreed that the ordinary meaning of baffles is “something for deflecting, checking, or otherwise regulating flow.” Phillips, 363 F.3d at 1216-17. In the dissent’s view, nothing in the specification redefined the term “baffles” or constituted a disclaimer specifically limiting the term to less than the full scope of its ordinary meaning. Instead, the dissenting judge contended, the specification “merely identifies impact resistance as one of several objectives of the invention.” Id. at 1217. In sum, the dissent concluded that “there is no reason to supplement the plain meaning of the claim language with a limitation from the preferred embodiment.” Id. at 1218. Consequently, the dissenting judge argued that the court should have adopted the general purpose dictionary definition of the term

baffle, i.e., “something for deflecting, checking, or otherwise regulating flow,” *id.*, and therefore should have reversed the summary judgment of noninfringement.

This court agreed to rehear the appeal en banc and vacated the judgment of the panel. Phillips v. AWH Corp., 376 F.3d 1382 (Fed. Cir. 2004). We now affirm the portion of the district court’s judgment addressed to the trade secret misappropriation claims. However, we reverse the portion of the court’s judgment addressed to the issue of infringement.

I

Claim 1 of the ’798 patent is representative of the asserted claims with respect to the use of the term “baffles.” It recites:

Building modules adapted to fit together for construction of fire, sound and impact resistant security barriers and rooms for use in securing records and persons, comprising in combination, an outer shell . . . , sealant means . . . and further means disposed inside the shell for increasing its load bearing capacity comprising internal steel baffles extending inwardly from the steel shell walls.

As a preliminary matter, we agree with the panel that the term “baffles” is not means-plus-function language that invokes 35 U.S.C. § 112, paragraph 6. To be sure, the claim refers to “means disposed inside the shell for increasing its load bearing capacity,” a formulation that would ordinarily be regarded as invoking the means-plus-function claim format. However, the claim specifically identifies “internal steel baffles” as structure that performs the recited function of increasing the shell’s load-bearing capacity. In contrast to the “load bearing means” limitation, the reference to “baffles” does not use the word “means,” and we have held that the absence of that term creates a rebuttable presumption that section 112, paragraph 6, does not apply. See

Personalized Media Communications, LLC v. Int'l Trade Comm'n, 161 F.3d 696, 703-04 (Fed. Cir. 1998).

Means-plus-function claiming applies only to purely functional limitations that do not provide the structure that performs the recited function. See Watts v. XL Sys., Inc., 232 F.3d 877, 880-81 (Fed. Cir. 2000). While the baffles in the '798 patent are clearly intended to perform several functions, the term “baffles” is nonetheless structural; it is not a purely functional placeholder in which structure is filled in by the specification. See TurboCare Div. of Demag Delaval Turbomachinery Corp. v. Gen. Elec. Co., 264 F.3d 1111, 1121 (Fed. Cir. 2001) (reasoning that nothing in the specification or prosecution history suggests that the patentee used the term “compressed spring” to denote any structure that is capable of performing the specified function); Greenberg v. Ethicon Endo-Surgery, Inc., 91 F.3d 1580, 1583 (Fed. Cir. 1996) (construing the term “detent mechanism” to refer to particular structure, even though the term has functional connotations). The claims and the specification unmistakably establish that the “steel baffles” refer to particular physical apparatus. The claim characterizes the baffles as “extend[ing] inwardly” from the steel shell walls, which plainly implies that the baffles are structures. The specification likewise makes clear that the term “steel baffles” refers to particular internal wall structures and is not simply a general description of any structure that will perform a particular function. See, e.g., '798 patent, col. 4, ll. 25-26 (“the load bearing baffles 16 are optionally used with longer panels”); id., col. 4, ll. 49-50 (opposing panels are “compressed between the flange 35 and the baffle 26”). Because the term “baffles” is not subject to section 112, paragraph 6, we agree with the panel that the district court erred by limiting the term to corresponding structures disclosed in the

specification and their equivalents. Accordingly, we must determine the correct construction of the structural term “baffles,” as used in the ’798 patent.

II

The first paragraph of section 112 of the Patent Act, 35 U.S.C. § 112, states that the specification

shall contain a written description of the invention, and of the manner and process of making and using it, in such full, clear, concise, and exact terms as to enable any person skilled in the art to which it pertains . . . to make and use the same

The second paragraph of section 112 provides that the specification

shall conclude with one or more claims particularly pointing out and distinctly claiming the subject matter which the applicant regards as his invention.

Those two paragraphs of section 112 frame the issue of claim interpretation for us. The second paragraph requires us to look to the language of the claims to determine what “the applicant regards as his invention.” On the other hand, the first paragraph requires that the specification describe the invention set forth in the claims. The principal question that this case presents to us is the extent to which we should resort to and rely on a patent’s specification in seeking to ascertain the proper scope of its claims.

This is hardly a new question. The role of the specification in claim construction has been an issue in patent law decisions in this country for nearly two centuries. We addressed the relationship between the specification and the claims at some length in our en banc opinion in Markman v. Westview Instruments, Inc., 52 F.3d 967, 979-81 (Fed. Cir. 1995) (en banc), aff’d, 517 U.S. 370 (1996). We again summarized the applicable principles in Vitronics Corp. v. Conceptor, Inc., 90 F.3d 1576 (Fed. Cir.

1996), and more recently in Innova/Pure Water, Inc. v. Safari Water Filtration Systems, Inc., 381 F.3d 1111 (Fed. Cir. 2004). What we said in those cases bears restating, for the basic principles of claim construction outlined there are still applicable, and we reaffirm them today. We have also previously considered the use of dictionaries in claim construction. What we have said in that regard requires clarification.

A

It is a “bedrock principle” of patent law that “the claims of a patent define the invention to which the patentee is entitled the right to exclude.” Innova, 381 F.3d at 1115; see also Vitronics, 90 F.3d at 1582 (“we look to the words of the claims themselves . . . to define the scope of the patented invention”); Markman, 52 F.3d at 980 (“The written description part of the specification itself does not delimit the right to exclude. That is the function and purpose of claims.”). That principle has been recognized since at least 1836, when Congress first required that the specification include a portion in which the inventor “shall particularly specify and point out the part, improvement, or combination, which he claims as his own invention or discovery.” Act of July 4, 1836, ch. 357, § 6, 5 Stat. 117, 119. In the following years, the Supreme Court made clear that the claims are “of primary importance, in the effort to ascertain precisely what it is that is patented.” Merrill v. Yeomans, 94 U.S. 568, 570 (1876). Because the patentee is required to “define precisely what his invention is,” the Court explained, it is “unjust to the public, as well as an evasion of the law, to construe it in a manner different from the plain import of its terms.” White v. Dunbar, 119 U.S. 47, 52 (1886); see also Cont’l Paper Bag Co. v. E. Paper Bag Co., 210 U.S. 405, 419 (1908) (“the claims measure the invention”); McCarty v. Lehigh Valley R.R. Co., 160 U.S. 110,

116 (1895) (“if we once begin to include elements not mentioned in the claim, in order to limit such claim . . . , we should never know where to stop”); Aro Mfg. Co. v. Convertible Top Replacement Co., 365 U.S. 336, 339 (1961) (“the claims made in the patent are the sole measure of the grant”).

We have frequently stated that the words of a claim “are generally given their ordinary and customary meaning.” Vitronics, 90 F.3d at 1582; see also Toro Co. v. White Consol. Indus., Inc., 199 F.3d 1295, 1299 (Fed. Cir. 1999); Renishaw PLC v. Marposs Societa’ per Azioni, 158 F.3d 1243, 1249 (Fed. Cir. 1998). We have made clear, moreover, that the ordinary and customary meaning of a claim term is the meaning that the term would have to a person of ordinary skill in the art in question at the time of the invention, i.e., as of the effective filing date of the patent application. See Innova, 381 F.3d at 1116 (“A court construing a patent claim seeks to accord a claim the meaning it would have to a person of ordinary skill in the art at the time of the invention.”); Home Diagnostics, Inc. v. LifeScan, Inc., 381 F.3d 1352, 1358 (Fed. Cir. 2004) (“customary meaning” refers to the “customary meaning in [the] art field”); Ferguson Beauregard/Logic Controls v. Mega Sys., LLC, 350 F.3d 1327, 1338 (Fed. Cir. 2003) (claim terms “are examined through the viewing glass of a person skilled in the art”); see also PC Connector Solutions LLC v. SmartDisk Corp., 406 F.3d 1359, 1363 (Fed. Cir. 2005) (meaning of claim “must be interpreted as of [the] effective filing date” of the patent application); Schering Corp. v. Amgen Inc., 222 F.3d 1347, 1353 (Fed. Cir. 2000) (same).

The inquiry into how a person of ordinary skill in the art understands a claim term provides an objective baseline from which to begin claim interpretation. See Innova,

381 F.3d at 1116. That starting point is based on the well-settled understanding that inventors are typically persons skilled in the field of the invention and that patents are addressed to and intended to be read by others of skill in the pertinent art. See Verve, LLC v. Crane Cams, Inc., 311 F.3d 1116, 1119 (Fed. Cir. 2002) (patent documents are meant to be “a concise statement for persons in the field”); In re Nelson, 280 F.2d 172, 181 (CCPA 1960) (“The descriptions in patents are not addressed to the public generally, to lawyers or to judges, but, as section 112 says, to those skilled in the art to which the invention pertains or with which it is most nearly connected.”).

Importantly, the person of ordinary skill in the art is deemed to read the claim term not only in the context of the particular claim in which the disputed term appears, but in the context of the entire patent, including the specification. This court explained that point well in Multiform Desiccants, Inc. v. Medzam, Ltd., 133 F.3d 1473, 1477 (Fed. Cir. 1998):

It is the person of ordinary skill in the field of the invention through whose eyes the claims are construed. Such person is deemed to read the words used in the patent documents with an understanding of their meaning in the field, and to have knowledge of any special meaning and usage in the field. The inventor’s words that are used to describe the invention—the inventor’s lexicography—must be understood and interpreted by the court as they would be understood and interpreted by a person in that field of technology. Thus the court starts the decisionmaking process by reviewing the same resources as would that person, viz., the patent specification and the prosecution history.

See also Medrad, Inc. v. MRI Devices Corp., 401 F.3d 1313, 1319 (Fed. Cir. 2005) (“We cannot look at the ordinary meaning of the term . . . in a vacuum. Rather, we must look at the ordinary meaning in the context of the written description and the prosecution history.”); V-Formation, Inc. v. Benetton Group SpA, 401 F.3d 1307, 1310 (Fed. Cir. 2005) (intrinsic record “usually provides the technological and temporal context to

enable the court to ascertain the meaning of the claim to one of ordinary skill in the art at the time of the invention”); Unitherm Food Sys., Inc. v. Swift-Eckrich, Inc., 375 F.3d 1341, 1351 (Fed. Cir. 2004) (proper definition is the “definition that one of ordinary skill in the art could ascertain from the intrinsic evidence in the record”).

B

In some cases, the ordinary meaning of claim language as understood by a person of skill in the art may be readily apparent even to lay judges, and claim construction in such cases involves little more than the application of the widely accepted meaning of commonly understood words. See Brown v. 3M, 265 F.3d 1349, 1352 (Fed Cir. 2001) (holding that the claims did “not require elaborate interpretation”). In such circumstances, general purpose dictionaries may be helpful. In many cases that give rise to litigation, however, determining the ordinary and customary meaning of the claim requires examination of terms that have a particular meaning in a field of art. Because the meaning of a claim term as understood by persons of skill in the art is often not immediately apparent, and because patentees frequently use terms idiosyncratically, the court looks to “those sources available to the public that show what a person of skill in the art would have understood disputed claim language to mean.” Innova, 381 F.3d at 1116. Those sources include “the words of the claims themselves, the remainder of the specification, the prosecution history, and extrinsic evidence concerning relevant scientific principles, the meaning of technical terms, and the state of the art.” Id.; see also Gemstar-TV Guide Int’l, Inc. v. Int’l Trade Comm’n, 383 F.3d 1352, 1364 (Fed. Cir. 2004); Vitronics, 90 F.3d at 1582-83; Markman, 52 F.3d at 979-80.

Quite apart from the written description and the prosecution history, the claims themselves provide substantial guidance as to the meaning of particular claim terms. See Vitronics, 90 F.3d at 1582; see also ACTV, Inc. v. Walt Disney Co., 346 F.3d 1082, 1088 (Fed. Cir. 2003) (“the context of the surrounding words of the claim also must be considered in determining the ordinary and customary meaning of those terms”).

To begin with, the context in which a term is used in the asserted claim can be highly instructive. To take a simple example, the claim in this case refers to “steel baffles,” which strongly implies that the term “baffles” does not inherently mean objects made of steel. This court’s cases provide numerous similar examples in which the use of a term within the claim provides a firm basis for construing the term. See, e.g., Mars, Inc. v. H.J. Heinz Co., 377 F.3d 1369, 1374 (Fed. Cir. 2004) (claim term “ingredients” construed in light of the use of the term “mixture” in the same claim phrase); Process Control Corp. v. HydReclaim Corp., 190 F.3d 1350, 1356 (Fed. Cir. 1999) (claim term “discharge rate” construed in light of the use of the same term in another limitation of the same claim).

Other claims of the patent in question, both asserted and unasserted, can also be valuable sources of enlightenment as to the meaning of a claim term. Vitronics, 90 F.3d at 1582. Because claim terms are normally used consistently throughout the patent, the usage of a term in one claim can often illuminate the meaning of the same term in other claims. See Rexnord Corp. v. Laitram Corp., 274 F.3d 1336, 1342 (Fed. Cir. 2001); CVI/Beta Ventures, Inc. v. Tura LP, 112 F.3d 1146, 1159 (Fed. Cir. 1997). Differences among claims can also be a useful guide in understanding the meaning of

particular claim terms. See Laitram Corp. v. Rexnord, Inc., 939 F.2d 1533, 1538 (Fed. Cir. 1991). For example, the presence of a dependent claim that adds a particular limitation gives rise to a presumption that the limitation in question is not present in the independent claim. See Liebel-Flarsheim Co. v. Medrad, Inc., 358 F.3d 898, 910 (Fed. Cir. 2004).

2

The claims, of course, do not stand alone. Rather, they are part of “a fully integrated written instrument,” Markman, 52 F.3d at 978, consisting principally of a specification that concludes with the claims. For that reason, claims “must be read in view of the specification, of which they are a part.” Id. at 979. As we stated in Vitronics, the specification “is always highly relevant to the claim construction analysis. Usually, it is dispositive; it is the single best guide to the meaning of a disputed term.” 90 F.3d at 1582.

This court and its predecessors have long emphasized the importance of the specification in claim construction. In Autogiro Co. of America v. United States, 384 F.2d 391, 397-98 (Ct. Cl. 1967), the Court of Claims characterized the specification as “a concordance for the claims,” based on the statutory requirement that the specification “describe the manner and process of making and using” the patented invention. The Court of Customs and Patent Appeals made a similar point. See In re Fout, 675 F.2d 297, 300 (CCPA 1982) (“Claims must always be read in light of the specification. Here, the specification makes plain what the appellants did and did not invent . . .”).

Shortly after the creation of this court, Judge Rich wrote that “[t]he descriptive part of the specification aids in ascertaining the scope and meaning of the claims

inasmuch as the words of the claims must be based on the description. The specification is, thus, the primary basis for construing the claims.” Standard Oil Co. v. Am. Cyanamid Co., 774 F.2d 448, 452 (Fed. Cir. 1985). On numerous occasions since then, we have reaffirmed that point, stating that “[t]he best source for understanding a technical term is the specification from which it arose, informed, as needed, by the prosecution history.” Multiform Dessicants, 133 F.3d at 1478; Metabolite Labs., Inc. v. Lab. Corp. of Am. Holdings, 370 F.3d 1354, 1360 (Fed. Cir. 2004) (“In most cases, the best source for discerning the proper context of claim terms is the patent specification wherein the patent applicant describes the invention.”); see also, e.g., Kinik Co. v. Int’l Trade Comm’n, 362 F.3d 1359, 1365 (Fed. Cir. 2004) (“The words of patent claims have the meaning and scope with which they are used in the specification and the prosecution history.”); Moba, B.V. v. Diamond Automation, Inc., 325 F.3d 1306, 1315 (Fed. Cir. 2003) (“[T]he best indicator of claim meaning is its usage in context as understood by one of skill in the art at the time of invention.”).

That principle has a long pedigree in Supreme Court decisions as well. See Hogg v. Emerson, 47 U.S. (6 How.) 437, 482 (1848) (the specification is a “component part of the patent” and “is as much to be considered with the [letters patent] in construing them, as any paper referred to in a deed or other contract”); Bates v. Coe, 98 U.S. 31, 38 (1878) (“in case of doubt or ambiguity it is proper in all cases to refer back to the descriptive portions of the specification to aid in solving the doubt or in ascertaining the true intent and meaning of the language employed in the claims”); White v. Dunbar, 119 U.S. 47, 51 (1886) (specification is appropriately resorted to “for the purpose of better understanding the meaning of the claim”); Schriber-Schroth Co. v.

Cleveland Trust Co., 311 U.S. 211, 217 (1940) (“The claims of a patent are always to be read or interpreted in light of its specifications.”); United States v. Adams, 383 U.S. 39, 49 (1966) (“[I]t is fundamental that claims are to be construed in the light of the specifications and both are to be read with a view to ascertaining the invention.”).

The importance of the specification in claim construction derives from its statutory role. The close kinship between the written description and the claims is enforced by the statutory requirement that the specification describe the claimed invention in “full, clear, concise, and exact terms.” 35 U.S.C. § 112, para. 1; see Network, LLC v. Centraal Corp., 242 F.3d 1347, 1352 (Fed. Cir. 2001) (“The claims are directed to the invention that is described in the specification; they do not have meaning removed from the context from which they arose.”); see also Markman v. Westview Instruments, Inc., 517 U.S. 370, 389 (1996) (“[A claim] term can be defined only in a way that comports with the instrument as a whole.”). In light of the statutory directive that the inventor provide a “full” and “exact” description of the claimed invention, the specification necessarily informs the proper construction of the claims. See Merck & Co. v. Teva Pharms. USA, Inc., 347 F.3d 1367, 1371 (Fed. Cir. 2003) (“A fundamental rule of claim construction is that terms in a patent document are construed with the meaning with which they are presented in the patent document. Thus claims must be construed so as to be consistent with the specification, of which they are a part.”) (citations omitted). In Renishaw, this court summarized that point succinctly:

Ultimately, the interpretation to be given a term can only be determined and confirmed with a full understanding of what the inventors actually invented and intended to envelop with the claim. The construction that stays true to the claim language and most naturally aligns with the patent’s description of the invention will be, in the end, the correct construction.

158 F.3d at 1250 (citations omitted).

Consistent with that general principle, our cases recognize that the specification may reveal a special definition given to a claim term by the patentee that differs from the meaning it would otherwise possess. In such cases, the inventor's lexicography governs. See CCS Fitness, Inc. v. Brunswick Corp., 288 F.3d 1359, 1366 (Fed. Cir. 2002). In other cases, the specification may reveal an intentional disclaimer, or disavowal, of claim scope by the inventor. In that instance as well, the inventor has dictated the correct claim scope, and the inventor's intention, as expressed in the specification, is regarded as dispositive. See SciMed Life Sys., Inc. v. Advanced Cardiovascular Sys., Inc., 242 F.3d 1337, 1343-44 (Fed. Cir. 2001).

The pertinence of the specification to claim construction is reinforced by the manner in which a patent is issued. The Patent and Trademark Office ("PTO") determines the scope of claims in patent applications not solely on the basis of the claim language, but upon giving claims their broadest reasonable construction "in light of the specification as it would be interpreted by one of ordinary skill in the art." In re Am. Acad. of Sci. Tech. Ctr., 367 F.3d 1359, 1364 (Fed. Cir. 2004). Indeed, the rules of the PTO require that application claims must "conform to the invention as set forth in the remainder of the specification and the terms and phrases used in the claims must find clear support or antecedent basis in the description so that the meaning of the terms in the claims may be ascertainable by reference to the description." 37 C.F.R. § 1.75(d)(1). It is therefore entirely appropriate for a court, when conducting claim construction, to rely heavily on the written description for guidance as to the meaning of the claims.

In addition to consulting the specification, we have held that a court “should also consider the patent’s prosecution history, if it is in evidence.” Markman, 52 F.3d at 980; see also Graham v. John Deere Co., 383 U.S. 1, 33 (1966) (“[A]n invention is construed not only in the light of the claims, but also with reference to the file wrapper or prosecution history in the Patent Office.”). The prosecution history, which we have designated as part of the “intrinsic evidence,” consists of the complete record of the proceedings before the PTO and includes the prior art cited during the examination of the patent. Autogiro, 384 F.2d at 399. Like the specification, the prosecution history provides evidence of how the PTO and the inventor understood the patent. See Lemelson v. Gen. Mills, Inc., 968 F.2d 1202, 1206 (Fed. Cir. 1992). Furthermore, like the specification, the prosecution history was created by the patentee in attempting to explain and obtain the patent. Yet because the prosecution history represents an ongoing negotiation between the PTO and the applicant, rather than the final product of that negotiation, it often lacks the clarity of the specification and thus is less useful for claim construction purposes. See Inverness Med. Switz. GmbH v. Warner Lambert Co., 309 F.3d 1373, 1380-82 (Fed. Cir. 2002) (the ambiguity of the prosecution history made it less relevant to claim construction); Athletic Alternatives, Inc. v. Prince Mfg., Inc., 73 F.3d 1573, 1580 (Fed. Cir. 1996) (the ambiguity of the prosecution history made it “unhelpful as an interpretive resource” for claim construction). Nonetheless, the prosecution history can often inform the meaning of the claim language by demonstrating how the inventor understood the invention and whether the inventor limited the invention in the course of prosecution, making the claim scope narrower than

it would otherwise be. Vitronics, 90 F.3d at 1582-83; see also Chimie v. PPG Indus., Inc., 402 F.3d 1371, 1384 (Fed. Cir. 2005) (“The purpose of consulting the prosecution history in construing a claim is to ‘exclude any interpretation that was disclaimed during prosecution.’”), quoting ZMI Corp. v. Cardiac Resuscitator Corp., 844 F.2d 1576, 1580 (Fed. Cir. 1988); Southwall Techs., Inc. v. Cardinal IG Co., 54 F.3d 1570, 1576 (Fed. Cir. 1995).

C

Although we have emphasized the importance of intrinsic evidence in claim construction, we have also authorized district courts to rely on extrinsic evidence, which “consists of all evidence external to the patent and prosecution history, including expert and inventor testimony, dictionaries, and learned treatises.” Markman, 52 F.3d at 980, citing Seymour v. Osborne, 78 U.S. (11 Wall.) 516, 546 (1870); see also Vitronics, 90 F.3d at 1583. However, while extrinsic evidence “can shed useful light on the relevant art,” we have explained that it is “less significant than the intrinsic record in determining ‘the legally operative meaning of claim language.’” C.R. Bard, Inc. v. U.S. Surgical Corp., 388 F.3d 858, 862 (Fed. Cir. 2004), quoting Vanderlande Indus. Nederland BV v. Int’l Trade Comm’n, 366 F.3d 1311, 1318 (Fed. Cir. 2004); see also Astrazeneca AB v. Mutual Pharm. Co., 384 F.3d 1333, 1337 (Fed. Cir. 2004).

Within the class of extrinsic evidence, the court has observed that dictionaries and treatises can be useful in claim construction. See Renishaw, 158 F.3d at 1250; Rexnord, 274 F.3d at 1344. We have especially noted the help that technical dictionaries may provide to a court “to better understand the underlying technology” and the way in which one of skill in the art might use the claim terms. Vitronics, 90 F.3d at

1584 n.6. Because dictionaries, and especially technical dictionaries, endeavor to collect the accepted meanings of terms used in various fields of science and technology, those resources have been properly recognized as among the many tools that can assist the court in determining the meaning of particular terminology to those of skill in the art of the invention. See Teleflex, Inc. v. Ficosa N. Am. Corp., 299 F.3d 1313, 1325 (Fed. Cir. 2002). Such evidence, we have held, may be considered if the court deems it helpful in determining “the true meaning of language used in the patent claims.” Markman, 52 F.3d at 980.

We have also held that extrinsic evidence in the form of expert testimony can be useful to a court for a variety of purposes, such as to provide background on the technology at issue, to explain how an invention works, to ensure that the court’s understanding of the technical aspects of the patent is consistent with that of a person of skill in the art, or to establish that a particular term in the patent or the prior art has a particular meaning in the pertinent field. See Pitney Bowes, Inc. v. Hewlett-Packard Co., 182 F.3d 1298, 1308-09 (Fed. Cir. 1999); Key Pharms. v. Hercon Labs. Corp., 161 F.3d 709, 716 (Fed. Cir. 1998). However, conclusory, unsupported assertions by experts as to the definition of a claim term are not useful to a court. Similarly, a court should discount any expert testimony “that is clearly at odds with the claim construction mandated by the claims themselves, the written description, and the prosecution history, in other words, with the written record of the patent.” Key Pharms., 161 F.3d at 716.

We have viewed extrinsic evidence in general as less reliable than the patent and its prosecution history in determining how to read claim terms, for several reasons.

First, extrinsic evidence by definition is not part of the patent and does not have the specification's virtue of being created at the time of patent prosecution for the purpose of explaining the patent's scope and meaning. Second, while claims are construed as they would be understood by a hypothetical person of skill in the art, extrinsic publications may not be written by or for skilled artisans and therefore may not reflect the understanding of a skilled artisan in the field of the patent. Third, extrinsic evidence consisting of expert reports and testimony is generated at the time of and for the purpose of litigation and thus can suffer from bias that is not present in intrinsic evidence. The effect of that bias can be exacerbated if the expert is not one of skill in the relevant art or if the expert's opinion is offered in a form that is not subject to cross-examination. See Senmed, Inc. v. Richard-Allan Med. Indus., Inc., 888 F.2d 815, 819 n.8 (Fed. Cir. 1989). Fourth, there is a virtually unbounded universe of potential extrinsic evidence of some marginal relevance that could be brought to bear on any claim construction question. In the course of litigation, each party will naturally choose the pieces of extrinsic evidence most favorable to its cause, leaving the court with the considerable task of filtering the useful extrinsic evidence from the fluff. See Daubert v. Merrell Dow Pharms., Inc., 509 U.S. 579, 595 (1993) ("Expert evidence can be both powerful and quite misleading because of the difficulty in evaluating it."). Finally, undue reliance on extrinsic evidence poses the risk that it will be used to change the meaning of claims in derogation of the "indisputable public records consisting of the claims, the specification and the prosecution history," thereby undermining the public notice function of patents. Southwall Techs., 54 F.3d at 1578.

In sum, extrinsic evidence may be useful to the court, but it is unlikely to result in a reliable interpretation of patent claim scope unless considered in the context of the intrinsic evidence. Nonetheless, because extrinsic evidence can help educate the court regarding the field of the invention and can help the court determine what a person of ordinary skill in the art would understand claim terms to mean, it is permissible for the district court in its sound discretion to admit and use such evidence. In exercising that discretion, and in weighing all the evidence bearing on claim construction, the court should keep in mind the flaws inherent in each type of evidence and assess that evidence accordingly.

III

Although the principles outlined above have been articulated on numerous occasions, some of this court's cases have suggested a somewhat different approach to claim construction, in which the court has given greater emphasis to dictionary definitions of claim terms and has assigned a less prominent role to the specification and the prosecution history. The leading case in this line is Texas Digital Systems, Inc. v. Telegenix, Inc., 308 F.3d 1193 (Fed. Cir. 2002).

A

In Texas Digital, the court noted that “dictionaries, encyclopedias and treatises are particularly useful resources to assist the court in determining the ordinary and customary meanings of claim terms.” 308 F.3d at 1202. Those texts, the court explained, are “objective resources that serve as reliable sources of information on the established meanings that would have been attributed to the terms of the claims by those of skill in the art,” and they “deserve no less fealty in the context of claim

construction” than in any other area of law. Id. at 1203. The court added that because words often have multiple dictionary meanings, the intrinsic record must be consulted to determine which of the different possible dictionary meanings is most consistent with the use of the term in question by the inventor. If more than one dictionary definition is consistent with the use of the words in the intrinsic record, the court stated, “the claim terms may be construed to encompass all such consistent meanings.” Id.

The Texas Digital court further explained that the patent’s specification and prosecution history must be consulted to determine if the patentee has used “the words [of the claim] in a manner clearly inconsistent with the ordinary meaning reflected, for example, in a dictionary definition.” 308 F.3d at 1204. The court identified two circumstances in which such an inconsistency may be found. First, the court stated, “the presumption in favor of a dictionary definition will be overcome where the patentee, acting as his or her own lexicographer, has clearly set forth an explicit definition of the term different from its ordinary meaning.” Id. Second, “the presumption also will be rebutted if the inventor has disavowed or disclaimed scope of coverage, by using words or expressions of manifest exclusion or restriction, representing a clear disavowal of claim scope.” Id.

The Texas Digital court explained that it advanced the methodology set forth in that opinion in an effort to combat what this court has termed “one of the cardinal sins of patent law—reading a limitation from the written description into the claims,” SciMed Life Sys., 242 F.3d at 1340. The court concluded that it is improper to consult “the written description and prosecution history as a threshold step in the claim construction process, before any effort is made to discern the ordinary and customary meanings

attributed to the words themselves.” Texas Digital, 308 F.3d at 1204. To do so, the court reasoned, “invites a violation of our precedent counseling against importing limitations into the claims.” Id. Summarizing its analysis, the Texas Digital court stated:

By examining relevant dictionaries, encyclopedias, and treatises to ascertain possible meanings that would have been attributed to the words of the claims by those skilled in the art, and by further utilizing the intrinsic record to select from those possible meanings the one or ones most consistent with the use of the words by the inventor, the full breadth of the limitations intended by the inventor will be more accurately determined and the improper importation of unintended limitations from the written description into the claims will be more easily avoided.

Id. at 1205.

B

Although the concern expressed by the court in Texas Digital was valid, the methodology it adopted placed too much reliance on extrinsic sources such as dictionaries, treatises, and encyclopedias and too little on intrinsic sources, in particular the specification and prosecution history. While the court noted that the specification must be consulted in every case, it suggested a methodology for claim interpretation in which the specification should be consulted only after a determination is made, whether based on a dictionary, treatise, or other source, as to the ordinary meaning or meanings of the claim term in dispute. Even then, recourse to the specification is limited to determining whether the specification excludes one of the meanings derived from the dictionary, whether the presumption in favor of the dictionary definition of the claim term has been overcome by “an explicit definition of the term different from its ordinary meaning,” or whether the inventor “has disavowed or disclaimed scope of coverage, by using words or expressions of manifest exclusion or restriction, representing a clear disavowal of claim scope.” 308 F.3d at 1204. In effect, the Texas Digital approach

limits the role of the specification in claim construction to serving as a check on the dictionary meaning of a claim term if the specification requires the court to conclude that fewer than all the dictionary definitions apply, or if the specification contains a sufficiently specific alternative definition or disavowal. See, e.g., Texas Digital, 308 F.3d at 1202 (“unless compelled otherwise, a court will give a claim term the full range of its ordinary meaning”); Nystrom v. TREX Co., 374 F.3d 1105, 1111-13 (Fed. Cir. 2004) (ascertaining the “full range” of the ordinary meaning of the term “board” through a collection of dictionary definitions, and stating that those candidate definitions should be removed from consideration only if they were “disclaimed” in the written description or prosecution history); Inverness Med. Switz., 309 F.3d at 1379 (claim should be construed to encompass multiple dictionary meanings unless “the specification or prosecution history clearly demonstrates that only one of the multiple meanings was intended”). That approach, in our view, improperly restricts the role of the specification in claim construction.

Assigning such a limited role to the specification, and in particular requiring that any definition of claim language in the specification be express, is inconsistent with our rulings that the specification is “the single best guide to the meaning of a disputed term,” and that the specification “acts as a dictionary when it expressly defines terms used in the claims or when it defines terms by implication.” Vitronics, 90 F.3d at 1582; Irdeto Access, Inc. v. EchoStar Satellite Corp., 383 F.3d 1295, 1300 (Fed. Cir. 2004) (“Even when guidance is not provided in explicit definitional format, the specification may define claim terms by implication such that the meaning may be found in or ascertained by a reading of the patent documents.”) (citations omitted); Novartis Pharms. Corp. v. Abbott

Labs., 375 F.3d 1328, 1334-35 (Fed. Cir. 2004) (same); Bell Atl. Network Servs., Inc. v. Covad Communications Group, Inc., 262 F.3d 1258, 1268 (Fed. Cir. 2001) (“[A] claim term may be clearly redefined without an explicit statement of redefinition.”).

The main problem with elevating the dictionary to such prominence is that it focuses the inquiry on the abstract meaning of words rather than on the meaning of claim terms within the context of the patent. Properly viewed, the “ordinary meaning” of a claim term is its meaning to the ordinary artisan after reading the entire patent. Yet heavy reliance on the dictionary divorced from the intrinsic evidence risks transforming the meaning of the claim term to the artisan into the meaning of the term in the abstract, out of its particular context, which is the specification. The patent system is based on the proposition that claims cover only the invented subject matter. As the Supreme Court has stated, “[i]t seems to us that nothing can be more just and fair, both to the patentee and the public, than that the former should understand, and correctly describe, just what he has invented, and for what he claims a patent.” Merrill v. Yeomans, 94 U.S. at 573-74. The use of a dictionary definition can conflict with that directive because the patent applicant did not create the dictionary to describe the invention. Thus, there may be a disconnect between the patentee’s responsibility to describe and claim his invention, and the dictionary editors’ objective of aggregating all possible definitions for particular words.

Although the Texas Digital line of cases permit the dictionary definition to be narrowed in some circumstances even when there is not an explicit disclaimer or redefinition in the specification, too often that line of cases has been improperly relied upon to condone the adoption of a dictionary definition entirely divorced from the

context of the written description. The problem is that if the district court starts with the broad dictionary definition in every case and fails to fully appreciate how the specification implicitly limits that definition, the error will systematically cause the construction of the claim to be unduly expansive. The risk of systematic overbreadth is greatly reduced if the court instead focuses at the outset on how the patentee used the claim term in the claims, specification, and prosecution history, rather than starting with a broad definition and whittling it down.

Dictionaries, by their nature, provide an expansive array of definitions. General dictionaries, in particular, strive to collect all uses of particular words, from the common to the obscure. By design, general dictionaries collect the definitions of a term as used not only in a particular art field, but in many different settings. In such circumstances, it is inevitable that the multiple dictionary definitions for a term will extend beyond the “construction of the patent [that] is confirmed by the avowed understanding of the patentee, expressed by him, or on his behalf, when his application for the original patent was pending.” Goodyear Dental Vulcanite Co. v. Davis, 102 U.S. 222, 227 (1880). Thus, the use of the dictionary may extend patent protection beyond what should properly be afforded by the inventor’s patent. See Smith v. Snow, 294 U.S. 1, 14 (1935) (“if the claim were fairly susceptible of two constructions, that should be adopted which will secure to the patentee his actual invention”) (emphasis added). For that reason, we have stated that “a general-usage dictionary cannot overcome art-specific evidence of the meaning” of a claim term. Vanderlande Indus. Nederland, 366 F.3d at 1321; see also Renishaw, 158 F.3d at 1250, quoting Liebscher v. Boothroyd, 258 F.2d 948, 951 (CCPA 1958) (“Indiscriminate reliance on definitions found in dictionaries can often

produce absurd results. . . . One need not arbitrarily pick and choose from the various accepted definitions of a word to decide which meaning was intended as the word is used in a given claim. The subject matter, the context, etc., will more often than not lead to the correct conclusion.”).

Even technical dictionaries or treatises, under certain circumstances, may suffer from some of these deficiencies. There is no guarantee that a term is used in the same way in a treatise as it would be by the patentee. In fact, discrepancies between the patent and treatises are apt to be common because the patent by its nature describes something novel. See Autogiro, 384 F.2d at 397 (“Often the invention is novel and words do not exist to describe it. The dictionary does not always keep abreast of the inventor. It cannot.”).

Moreover, different dictionaries may contain somewhat different sets of definitions for the same words. A claim should not rise or fall based upon the preferences of a particular dictionary editor, or the court’s independent decision, uninformed by the specification, to rely on one dictionary rather than another. Finally, the authors of dictionaries or treatises may simplify ideas to communicate them most effectively to the public and may thus choose a meaning that is not pertinent to the understanding of particular claim language. See generally Ellen P. Aprill, The Law of the Word: Dictionary Shopping in the Supreme Court, 30 Ariz. St. L.J. 275, 293-314 (1998). The resulting definitions therefore do not necessarily reflect the inventor’s goal of distinctly setting forth his invention as a person of ordinary skill in that particular art would understand it.

As we have noted above, however, we do not intend to preclude the appropriate use of dictionaries. Dictionaries or comparable sources are often useful to assist in understanding the commonly understood meaning of words and have been used both by our court and the Supreme Court in claim interpretation. See Exhibit Supply Co. v. Ace Patents Corp., 315 U.S. 126, 134 (1942) (relying on dictionaries to construe the claim term “embedded”); Weber Elec. Co. v. E.H. Freeman Elec. Co., 256 U.S. 668, 678 (1921) (approving circuit court’s use of dictionary definitions to define claim terms); Renishaw, 158 F.3d at 1247-53 (approving the use of dictionaries with proper respect for the role of intrinsic evidence). A dictionary definition has the value of being an unbiased source “accessible to the public in advance of litigation.” Vitronics, 90 F.3d at 1585. As we said in Vitronics, judges are free to consult dictionaries and technical treatises

at any time in order to better understand the underlying technology and may also rely on dictionary definitions when construing claim terms, so long as the dictionary definition does not contradict any definition found in or ascertained by a reading of the patent documents.

Id. at 1584 n.6.

We also acknowledge that the purpose underlying the Texas Digital line of cases—to avoid the danger of reading limitations from the specification into the claim—is sound. Moreover, we recognize that the distinction between using the specification to interpret the meaning of a claim and importing limitations from the specification into the claim can be a difficult one to apply in practice. See Comark Communications, Inc. v. Harris Corp., 156 F.3d 1182, 1186-87 (Fed. Cir. 1998) (“there is sometimes a fine line between reading a claim in light of the specification, and reading a limitation into the claim from the specification”). However, the line between construing terms and

importing limitations can be discerned with reasonable certainty and predictability if the court's focus remains on understanding how a person of ordinary skill in the art would understand the claim terms. For instance, although the specification often describes very specific embodiments of the invention, we have repeatedly warned against confining the claims to those embodiments. See, e.g., Nazomi Communications, Inc. v. ARM Holdings, PLC, 403 F.3d 1364, 1369 (Fed. Cir. 2005) (claims may embrace "different subject matter than is illustrated in the specific embodiments in the specification"); Liebel-Flarsheim, 358 F.3d at 906-08; Teleflex, 299 F.3d at 1327; SRI Int'l v. Matsushita Elec. Corp. of Am., 775 F.2d 1107, 1121 (Fed. Cir. 1985). In particular, we have expressly rejected the contention that if a patent describes only a single embodiment, the claims of the patent must be construed as being limited to that embodiment. Gemstar-TV Guide, 383 F.3d at 1366. That is not just because section 112 of the Patent Act requires that the claims themselves set forth the limits of the patent grant, but also because persons of ordinary skill in the art rarely would confine their definitions of terms to the exact representations depicted in the embodiments.

To avoid importing limitations from the specification into the claims, it is important to keep in mind that the purposes of the specification are to teach and enable those of skill in the art to make and use the invention and to provide a best mode for doing so. See Spectra-Physics, Inc. v. Coherent, Inc., 827 F.2d 1524, 1533 (Fed. Cir. 1987). One of the best ways to teach a person of ordinary skill in the art how to make and use the invention is to provide an example of how to practice the invention in a particular case. Much of the time, upon reading the specification in that context, it will become clear whether the patentee is setting out specific examples of the invention to accomplish

those goals, or whether the patentee instead intends for the claims and the embodiments in the specification to be strictly coextensive. See SciMed Life Sys., 242 F.3d at 1341. The manner in which the patentee uses a term within the specification and claims usually will make the distinction apparent. See Snow v. Lake Shore & M.S. Ry. Co., 121 U.S. 617, 630 (1887) (it was clear from the specification that there was “nothing in the context to indicate that the patentee contemplated any alternative” embodiment to the one presented).

In the end, there will still remain some cases in which it will be hard to determine whether a person of skill in the art would understand the embodiments to define the outer limits of the claim term or merely to be exemplary in nature. While that task may present difficulties in some cases, we nonetheless believe that attempting to resolve that problem in the context of the particular patent is likely to capture the scope of the actual invention more accurately than either strictly limiting the scope of the claims to the embodiments disclosed in the specification or divorcing the claim language from the specification.

In Vitronics, this court grappled with the same problem and set forth guidelines for reaching the correct claim construction and not imposing improper limitations on claims. 90 F.3d at 1582. The underlying goal of our decision in Vitronics was to increase the likelihood that a court will comprehend how a person of ordinary skill in the art would understand the claim terms. See id. at 1584. In that process, we recognized that there is no magic formula or catechism for conducting claim construction. Nor is the court barred from considering any particular sources or required to analyze sources in any specific sequence, as long as those sources are not used to contradict claim

meaning that is unambiguous in light of the intrinsic evidence. See id. at 1583-84; Intel Corp. v. VIA Techs., Inc., 319 F.3d 1357, 1367 (Fed. Cir. 2003). For example, a judge who encounters a claim term while reading a patent might consult a general purpose or specialized dictionary to begin to understand the meaning of the term, before reviewing the remainder of the patent to determine how the patentee has used the term. The sequence of steps used by the judge in consulting various sources is not important; what matters is for the court to attach the appropriate weight to be assigned to those sources in light of the statutes and policies that inform patent law. Vitronics, 90 F.3d at 1582. In Vitronics, we did not attempt to provide a rigid algorithm for claim construction, but simply attempted to explain why, in general, certain types of evidence are more valuable than others. Today, we adhere to that approach and reaffirm the approach to claim construction outlined in that case, in Markman, and in Innova. We now turn to the application of those principles to the case at bar.

IV

A

The critical language of claim 1 of the '798 patent—"further means disposed inside the shell for increasing its load bearing capacity comprising internal steel baffles extending inwardly from the steel shell walls"—imposes three clear requirements with respect to the baffles. First, the baffles must be made of steel. Second, they must be part of the load-bearing means for the wall section. Third, they must be pointed inward from the walls. Both parties, stipulating to a dictionary definition, also conceded that the term "baffles" refers to objects that check, impede, or obstruct the flow of something.

The intrinsic evidence confirms that a person of skill in the art would understand that the term “baffles,” as used in the '798 patent, would have that generic meaning.

The other claims of the '798 patent specify particular functions to be served by the baffles. For example, dependent claim 2 states that the baffles may be “oriented with the panel sections disposed at angles for deflecting projectiles such as bullets able to penetrate the steel plates.” The inclusion of such a specific limitation on the term “baffles” in claim 2 makes it likely that the patentee did not contemplate that the term “baffles” already contained that limitation. See Dow Chem. Co. v. United States, 226 F.3d 1334, 1341-42 (Fed. Cir. 2000) (concluding that an independent claim should be given broader scope than a dependent claim to avoid rendering the dependent claim redundant). Independent claim 17 further supports that proposition. It states that baffles are placed “projecting inwardly from the outer shell at angles tending to deflect projectiles that penetrate the outer shell.” That limitation would be unnecessary if persons of skill in the art understood that the baffles inherently served such a function. See TurboCare, 264 F.3d at 1123 (claim terms should not be read to contain a limitation “where another claim restricts the invention in exactly the [same] manner”). Dependent claim 6 provides an additional requirement for the baffles, stating that “the internal baffles of both outer panel sections overlap and interlock at angles providing deflector panels extending from one end of the module to the other.” If the baffles recited in claim 1 were inherently placed at specific angles, or interlocked to form an intermediate barrier, claim 6 would be redundant.

The specification further supports the conclusion that persons of ordinary skill in the art would understand the baffles recited in the '798 patent to be load-bearing objects

that serve to check, impede, or obstruct flow. At several points, the specification discusses positioning the baffles so as to deflect projectiles. See '798 patent, col. 2, ll. 13-15; id., col. 5, ll. 17-19. The patent states that one advantage of the invention over the prior art is that “[t]here have not been effective ways of dealing with these powerful impact weapons with inexpensive housing.” Id., col. 3, ll. 28-30. While that statement makes clear the invention envisions baffles that serve that function, it does not imply that in order to qualify as baffles within the meaning of the claims, the internal support structures must serve the projectile-deflecting function in all the embodiments of all the claims. The specification must teach and enable all the claims, and the section of the written description discussing the use of baffles to deflect projectiles serves that purpose for claims 2, 6, 17, and 23, which specifically claim baffles that deflect projectiles. See In re Wright, 999 F.2d 1557, 1561 (Fed. Cir. 1993).

The specification discusses several other purposes served by the baffles. For example, the baffles are described as providing structural support. The patent states that one way to increase load-bearing capacity is to use “at least in part inwardly directed steel baffles 15, 16.” '798 patent, col. 4, ll. 14-15. The baffle 16 is described as a “strengthening triangular baffle.” Id., col. 4, line 37. Importantly, Figures 4 and 6 do not show the baffles as part of an “intermediate interlocking, but not solid, internal barrier.” In those figures, the baffle 16 simply provides structural support for one of the walls, as depicted below:

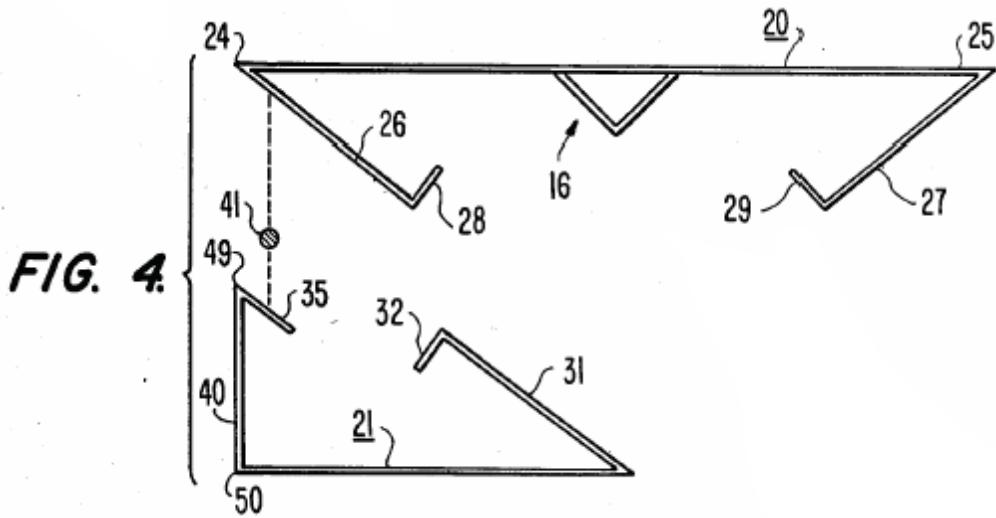
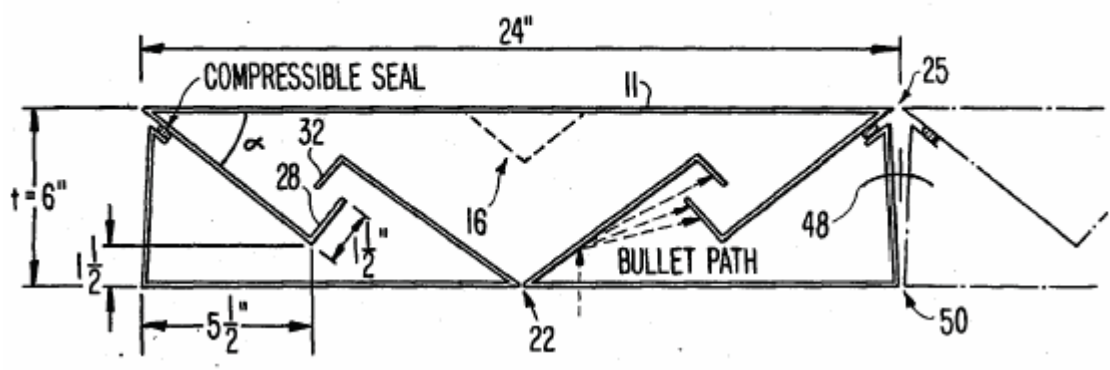
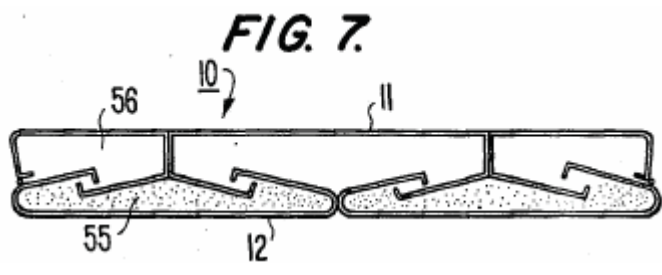

FIG. 6.



Other uses for the baffles are listed in the specification as well. In Figure 7, the overlapping flanges "provide for overlapping and interlocking the baffles to produce substantially an intermediate barrier wall between the opposite [wall] faces":



'798 patent, col. 5, ll. 26-29. Those baffles thus create small compartments that can be filled with either sand and thermal insulation or rock and gravel to stop projectiles. Id.,

col. 5, ll. 29-34. By separating the interwall area into compartments (see, e.g., compartment 55 in Figure 7), the user of the modules can choose different types of material for each compartment, so that the module can be “easily custom tailored for the specific needs of each installation.” Id., col. 5, ll. 36-37. When material is placed into the wall during installation, the baffles obstruct the flow of material from one compartment to another so that this “custom tailoring” is possible.

The fact that the written description of the '798 patent sets forth multiple objectives to be served by the baffles recited in the claims confirms that the term “baffles” should not be read restrictively to require that the baffles in each case serve all of the recited functions. We have held that “[t]he fact that a patent asserts that an invention achieves several objectives does not require that each of the claims be construed as limited to structures that are capable of achieving all of the objectives.” Liebel-Flarsheim, 358 F.3d at 908; see also Resonate Inc. v. Alteon Websystems, Inc., 338 F.3d 1360, 1367 (Fed. Cir. 2003). Although deflecting projectiles is one of the advantages of the baffles of the '798 patent, the patent does not require that the inward extending structures always be capable of performing that function. Accordingly, we conclude that a person of skill in the art would not interpret the disclosure and claims of the '798 patent to mean that a structure extending inward from one of the wall faces is a “baffle” if it is at an acute or obtuse angle, but is not a “baffle” if it is disposed at a right angle.

B

Invoking the principle that “claims should be so construed, if possible, as to sustain their validity,” Rhine v. Casio, Inc., 183 F.3d 1342, 1345 (Fed Cir. 1999), AWH

argues that the term “baffles” should be given a restrictive meaning because if the term is not construed restrictively, the asserted claims would be invalid.

While we have acknowledged the maxim that claims should be construed to preserve their validity, we have not applied that principle broadly, and we have certainly not endorsed a regime in which validity analysis is a regular component of claim construction. See Nazomi Communications, 403 F.3d at 1368-69. Instead, we have limited the maxim to cases in which “the court concludes, after applying all the available tools of claim construction, that the claim is still ambiguous.” Liebel-Flarsheim, 358 F.3d at 911; see also Generation II Orthonics Inc. v. Med. Tech. Inc., 263 F.3d 1356, 1365 (Fed. Cir. 2001) (“[C]laims can only be construed to preserve their validity where the proposed claim construction is ‘practicable,’ is based on sound claim construction principles, and does not revise or ignore the explicit language of the claims.”); Elekta Instrument S.A. v. O.U.R. Scientific Int’l, Inc., 214 F.3d 1302, 1309 (Fed. Cir. 2000) (“having concluded that the amended claim is susceptible of only one reasonable construction, we cannot construe the claim differently from its plain meaning in order to preserve its validity”); E.I. du Pont de Nemours & Co. v. Phillips Petroleum Co., 849 F.2d 1430, 1434 (Fed. Cir. 1988) (rejecting argument that limitations should be added to claims to preserve the validity of the claims). In such cases, we have looked to whether it is reasonable to infer that the PTO would not have issued an invalid patent, and that the ambiguity in the claim language should therefore be resolved in a manner that would preserve the patent’s validity.

That is the rationale that gave rise to the maxim in the first place. In Klein v. Russell, 86 U.S. (19 Wall.) 433, 466 (1873), the owner of a reissued patent argued for a

narrow construction of the patent, while the accused infringer argued for a broader construction. The Court noted that the law “required that the reissue should be for the same invention as the original patent.” Id. Because the reissue, which was granted under the predecessor to 35 U.S.C. § 251, would have been improper under the broader construction, the Court “presumed the Commissioner did his duty” and did not issue an invalid patent. For that reason, among others, the Court construed the disputed claim language in a manner that “sustain[ed] the patent and the construction claimed by the patentee,” since that “can be done consistently with the language which he has employed.” Id. The applicability of the doctrine in a particular case therefore depends on the strength of the inference that the PTO would have recognized that one claim interpretation would render the claim invalid, and that the PTO would not have issued the patent assuming that to be the proper construction of the term.

In this case, unlike in Klein and other cases in which the doctrine of construing claims to preserve their validity has been invoked, the claim term at issue is not ambiguous. Thus, it can be construed without the need to consider whether one possible construction would render the claim invalid while the other would not. The doctrine of construing claims to preserve their validity, a doctrine of limited utility in any event, therefore has no applicability here.

In sum, we reject AWH’s arguments in favor of a restrictive definition of the term “baffles.” Because we disagree with the district court’s claim construction, we reverse the summary judgment of noninfringement. In light of our decision on claim construction, it is necessary to remand the infringement claims to the district court for further proceedings.

V

With respect to Mr. Phillips's allegation of misappropriation of trade secrets, we agree with the panel's decision upholding the district court's ruling on that issue, in which the district court dismissed the trade secret claim on statute of limitations grounds. See Phillips, 363 F.3d at 1214-1216. Accordingly, based on the panel's disposition of that issue, we affirm the district court's dismissal of the trade secret claim. With respect to AWH's cross-appeal, we also agree with the panel's reasoning and its conclusion that the cross-appeal is improper. See id. at 1216. We therefore dismiss the cross-appeal.

VI

In our order granting rehearing en banc, we asked the parties to brief various questions, including the following: "Consistent with the Supreme Court's decision in Markman v. Westview Instruments, 517 U.S. 370 (1996), and our en banc decision in Cybor Corp. v. FAS Technologies, Inc., 138 F.3d 1448 (Fed. Cir. 1998), is it appropriate for this court to accord any deference to any aspect of trial court claim construction rulings? If so, on what aspects, in what circumstances, and to what extent?" After consideration of the matter, we have decided not to address that issue at this time. We therefore leave undisturbed our prior en banc decision in Cybor.

Each party shall bear its own costs for this appeal.

AFFIRMED IN PART, REVERSED IN PART, DISMISSED IN PART, and REMANDED.

United States Court of Appeals for the Federal Circuit

03-1269,-1286

EDWARD H. PHILLIPS,

Plaintiff-Appellant,

v.

AWH CORPORATION,
HOPEMAN BROTHERS, INC., and LOFTON CORPORATION,

Defendants-Cross Appellants.

LOURIE, Circuit Judge, concurring in part and dissenting in part, with whom NEWMAN, Circuit Judge, joins.

I fully join the portion of the court's opinion resolving the relative weights of specification and dictionaries in interpreting patent claims, in favor of the specification. I could elaborate more expansively on that topic, but Judge Bryson's opinion for the majority says it so well, there is little reason for me to repeat its truths. I also agree with the court that claims need not necessarily be limited to specific or preferred embodiments in the specification, although they are limited to what is contained in the overall disclosure of the specification.

However, I do dissent from the court's decision to reverse and remand the district court's decision. The original panel decision of this court, which implicitly decided the case based on the priorities that the en banc court has now reaffirmed, interpreted the claims in light of the specification and found that the defendant did not infringe the

claims. We affirmed the district court, which had arrived at a similar conclusion. The dissent from the panel decision relied on the "dictionaries first" procedure, which the court now has decided not to follow. Thus, while the claim construction issue had to be decided by the en banc court, I see no reason for the court, having reaffirmed the principle on which the district judge and the panel originally decided the case, to send it back for further review.

The court premises its reverse-and-remand decision on the concept of claim differentiation and the reasoning that the contested term "baffle" need not fulfill all of the functions set out for it in the specification. Reasonable people can differ on those points. However, the court did not take this case en banc because the full court differed with the panel majority on those disputable criteria. It did so to resolve the claim construction issue, which it has now done so well. Having done so, I believe that it should simply affirm the district court's decision on the merits, consistently with that court's rationale and that of the panel that affirmed the district court, which it now adopts.

I will not critique in detail particular statements the majority makes in rationalizing its reversal of the district court's decision, such as "that a person of skill in the art would not interpret the disclosure and claims of the '798 patent to mean that a structure extending inward from one of the wall faces is a 'baffle' if it is at an acute or obtuse angle, but is not a 'baffle' if it is disposed at a right angle," or that "the patent does not require that the inward extending structures always be capable of performing that function [deflecting projectiles]" in order to be considered 'baffles'.

I will simply point out that the specification contains no disclosure of baffles at right angles. Moreover, as the majority correctly states, a patent specification is intended to describe one's invention, and it is essential to read a specification in order to interpret the meaning of the claims. This specification makes clear that the "baffles" in this invention are angled. There is no reference to baffles that show them to be other than angled. The abstract refers to "bullet deflecting . . . baffles." Only angled baffles can deflect. It then mentions "internal baffles at angles for deflecting bullets." That could not be clearer. The specification then refers several times to baffles, often to figures in the drawings, all of which are to angled baffles. A compelling point is that the only numbered references to baffles (15, 16, 26, 27, 30, and 31) all show angled baffles.

The specification further states that steel panels "form the internal baffles at angles for deflecting bullets." It states that the baffles are "disposed at such angles that bullets which might penetrate the outer steel panels are deflected." It explains that if bullets "were to penetrate the outer steel wall, the baffles are disposed at angles which tend to deflect the bullets." There is no specific reference in this patent to a baffle that is not angled at other than 90°.

While, as the majority states, the specification indicates that multiple objectives are achieved by the invention, none of the other objectives is dependent upon whether the baffles are at other than a 90° angle, whereas the constantly stated objective of deflection of bullets is dependent upon such an angle.

Finally, even though claim construction is a question of law, reviewable by this court without formal deference, I do believe that we ought to lean toward affirmance of a claim construction in the absence of a strong conviction of error. I do not have such a

conviction in this case, after considering the district court's opinion and the patent specification.

For these reasons, while I wholeheartedly join the majority opinion in its discussion and resolution of the "specification v. dictionaries" issue, I would affirm the decision below.

United States Court of Appeals for the Federal Circuit

03-1269, -1286

EDWARD H. PHILLIPS,

Plaintiff-Appellant,

v.

AWH CORPORATION,
HOPEMAN BROTHERS, INC., and LOFTON CORPORATION,

Defendants-Cross Appellants.

MAYER, Circuit Judge, with whom NEWMAN, Circuit Judge, joins, dissenting.

Now more than ever I am convinced of the futility, indeed the absurdity, of this court's persistence in adhering to the falsehood that claim construction is a matter of law devoid of any factual component. Because any attempt to fashion a coherent standard under this regime is pointless, as illustrated by our many failed attempts to do so, I dissent.

This court was created for the purpose of bringing consistency to the patent field. See H.R. Rep. No. 312, 97th Cong., 1st Sess. 20-23 (1981). Instead, we have taken this noble mandate, to reinvigorate the patent and introduce predictability to the field, and focused inappropriate power in this court. In our quest to elevate our importance, we have, however, disregarded our role as an appellate court; the resulting mayhem has seriously undermined the legitimacy of the process, if not the integrity of the institution.

In the name of uniformity, Cybor Corp. v. FAS Technologies, Inc., 138 F.3d 1448 (Fed. Cir. 1998) (en banc), held that claim construction does not involve subsidiary or underlying questions of fact and that we are, therefore, unbridled by either the expertise or efforts of the district court.¹ What we have wrought, instead, is the substitution of a black box, as it so pejoratively has been said of the jury, with the black hole of this court. Out of this void we emit “legal” pronouncements by way of “interpretive necromancy”²; these rulings resemble reality, if at all, only by chance. Regardless, and with a blind eye to the consequences, we continue to struggle under this irrational and reckless regime, trying every alternative—dictionaries first, dictionaries second, never dictionaries, etc., etc., etc.

Again today we vainly attempt to establish standards by which this court will interpret claims. But after proposing no fewer than seven questions, receiving more than thirty amici curiae briefs, and whipping the bar into a frenzy of expectation, we say nothing new, but merely restate what has become the practice over the last ten years—that we will decide cases according to whatever mode or method results in the outcome we desire, or at least allows us a seemingly plausible way out of the case. I am not surprised by this. Indeed, there can be no workable standards by which this court will interpret claims so long as we are blind to the factual component of the task. See

¹ The Supreme Court did not suggest in affirming Markman v. Westview Instruments, Inc., 52 F.3d 967 (1995) (en banc), that claim construction is a purely legal question. 517 U.S. 370 (1996). It held only that, as a policy matter, the judge, as opposed to the jury, should determine the meaning of a patent claim. See Cybor, 138 F.3d at 1464 (Mayer, C.J., dissenting) (explaining that “the [Supreme] Court chose not to accept our formulation of claim construction: as a pure question of law to be decided de novo in all cases on appeal”).

² See The Holmes Group, Inc. v. Vornado Air Circulation Sys., Inc., 535 U.S. 826, 833 (2002).

Cooter & Gell v. Hartmarx Corp., 496 U.S. 384, 405 (1990) (“Fact-bound resolutions cannot be made uniform through appellate review, de novo or otherwise.” (quoting Mars Steel Corp. v. Cont’l Bank N.A., 880 F.2d 928, 936 (7th Cir.1989))).³

Federal Rule of Civil Procedure 52(a) states that “[f]indings of fact . . . shall not be set aside unless clearly erroneous, and due regard shall be given to the opportunity of the trial court to judge of the credibility of witnesses.” According to the Supreme Court, this “[r]ule means what it says”—that findings of fact, even “those described as ‘ultimate facts’ because they may determine the outcome of litigation,” are to be reviewed deferentially on appeal.⁴ Bose Corp. v. Consumers Union of United States,

³ The question asked but not answered by the court which might have allowed it to cure its self-inflicted wound was: “Question 7. Consistent with the Supreme Court’s decision in Markman v. Westview Instruments, Inc., 517 U.S. 370 (1996) and our *en banc* decision in Cybor Corp. v. FAS Technologies, Inc., 138 F.3d 1448 (Fed. Cir. 1998), is it appropriate for this court to accord any deference to any aspect of trial court claim construction rulings? If so, on what aspects, in what circumstances, and to what extent?”

⁴ Because some facts are so intertwined with a constitutional standard the Supreme Court has held that de novo review is appropriate. For example, whether a defendant has acted with actual malice in a defamation suit is reviewed de novo because, among other reasons, the scope of the First Amendment is shaped and applied by reference to such factual determinations. Bose, 466 U.S. at 502 (“[T]he content of the rule is not revealed simply by its literal text, but rather is given meaning through the evolutionary process of common-law adjudication.”). Similarly, whether there is reasonable suspicion to conduct an investigatory stop or probable cause to perform a search under the Fourth Amendment are reviewed without deference. Ornelas v. United States, 517 U.S. 690, 696 (1996) (holding that the protections afforded by the Fourth Amendment are “fluid concepts that take their substantive content from the particular contexts in which the standards are being assessed”). The reasoning behind these limited exceptions surely does not apply to claim construction. While appearing from the perspective of this court’s limited sphere of influence to be dreadfully important, claim construction does not implicate a constitutional value. Cf. Bose, 466 U.S. at 502 (“[T]he constitutional values protected by the rule make it imperative that judges—and in some cases judges of [the Supreme] Court—make sure that it is correctly applied.”). This is illustrated by the fact that the outcome of a patent case, unlike a defamation or illegal search case, has little impact on how future cases

466 U.S. 485, 498 & 501 (1984); see also Anderson v. Bessemer City, 470 U.S. 564, 575 (1985) (“[R]eview of factual findings under the clearly-erroneous standard—with its deference to the trier of fact—is the rule, not the exception.”); Pullman-Standard v. United Steel Workers of Am., 456 U.S. 273, 287 (1982) (“Rule 52(a) broadly requires that findings of fact not be set aside unless clearly erroneous.”); United States v. United States Gypsum Co., 333 U.S. 364, 394 (1948). Even those findings of fact based entirely on documentary evidence are entitled to deference. Anderson, 470 U.S. at 574 (“That [Rule 52(a)] goes on to emphasize the special deference to be paid credibility determinations does not alter its clear command: Rule 52(a) ‘does not make exceptions or purport to exclude certain categories of factual findings from the obligation of a court of appeals to accept a district court’s findings unless clearly erroneous.’” (quoting Pullman-Standard, 456 U.S. at 287)). In short, we are obligated by Rule 52(a) to review the factual findings of the district court that underlie the determination of claim construction for clear error.

While this court may persist in the delusion that claim construction is a purely legal determination, unaffected by underlying facts, it is plainly not the case. Claim construction is, or should be, made in context: a claim should be interpreted both from the perspective of one of ordinary skill in the art and in view of the state of the art at the time of invention. See Multiform Desiccants, Inc. v. Medzam, Ltd., 133 F.3d 1473, 1477

are decided or on how future parties behave. Cf. id. at 501 n.17 (“Regarding certain largely factual questions in some areas of the law, the stakes—in terms of impact on future cases and future conduct—are too great to entrust them finally to the judgment of the trier of fact.”). Even if claim construction did implicate a constitutional value, it, unlike the decisions underlying the First and Fourth Amendments, could readily be reduced, when distinguished from its factual underpinnings, to “a neat set of legal rules.” Ornelas, 517 U.S. at 695-96 (quoting Ill. v. Gates, 462 U.S. 213, 232 (1983)).

(Fed. Cir. 1998) (“It is the person of ordinary skill in the field of the invention through whose eyes the claims are construed.”). These questions, which are critical to the correct interpretation of a claim, are inherently factual. They are hotly contested by the parties, not by resort to case law as one would expect for legal issues, but based on testimony and documentary evidence.⁵ During so called Markman “hearings,” which are often longer than jury trials, parties battle over experts offering conflicting evidence regarding who qualifies as one of ordinary skill in the art; the meaning of patent terms to that person; the state of the art at the time of the invention; contradictory dictionary definitions and which would be consulted by the skilled artisan; the scope of specialized terms; the problem a patent was solving; what is related or pertinent art; whether a construction was disallowed during prosecution; how one of skill in the art would understand statements during prosecution; and on and on. In order to reconcile the parties’ inconsistent submissions and arrive at a sound interpretation, the district court is required to sift through and weigh volumes of evidence. While this court treats the district court as an intake clerk, whose only role is to collect, shuffle and collate evidence, the reality, as revealed by conventional practice, is far different.

Even if the procedures employed by the district court did not show that it is engaging in factfinding, the nature of the questions underlying claim construction illustrate that they are factual and should be reviewed in accordance with Rule 52(a). For each patent, for example, who qualifies as one of ordinary skill in the art will differ,

⁵ That most of the cases now appealed to this court are “summary judgments” is irrelevant. We have artificially renamed findings of fact as legal conclusions; the district courts have dutifully conformed to our fictional characterization, but this does not change the inherent nature of the inquiry. Of course, if the parties do not dispute the material facts, summary judgment is appropriate.

just as the state of the art at the time of invention will differ. These subsidiary determinations are specific, multifarious and not susceptible to generalization; as such their resolution in one case will bear very little, if at all, on the resolution of subsequent cases. See Ornelas, 517 U.S. at 703 (“Law clarification requires generalization, and some issues lend themselves to generalization much more than others.”); Pierce v. Underwood, 487 U.S. 552, 561-62 (1988) (“Many questions that arise in litigation are not amenable to regulation by rule because they involve multifarious, fleeting, special, narrow facts that utterly resist generalization.” (quoting Maurice Rosenberg, Judicial Discretion of the Trial Court, Viewed from Above, 22 Syracuse L. Rev. 635, 662 (1971))); Icicle Seafoods, Inc. v. Worthington, 475 U.S. 709, 714 (1986) (rejecting de novo review of factual questions, even when outcome determinative). That the determination of the meaning of a particular term in one patent will not necessarily bear on the interpretation of the same term in a subsequent patent illustrates this point; while the term is the same, the underlying factual context is different. It further proves that these questions (e.g., who qualifies as one of ordinary skill in the art and what was the state of the art at the time of invention, among others) are implicitly being determined in each case; because we refuse to acknowledge either their existence or importance, however, the manner of their resolution is never elucidated. Finally, that claim construction is dependent on underlying factual determinations has been verified by our experience, which shows that reviewing these questions de novo has not clarified the law, but has instead “distort[ed] the appellate process,” causing confusion among the district courts and bar. See Cooter, 496 U.S. at 404 (quoting Pierce, 487 U.S. at 561); see also Koon v. United States, 518 U.S. 81, 99 (1996).

Our purely de novo review of claim interpretation also cannot be reconciled with the Supreme Court's instructions regarding obviousness. While ultimately a question of law, obviousness depends on several underlying factual inquiries. Graham v. John Deere Co., 383 U.S. 1, 17 (1966); see also Dennison Mfg. Co. v. Panduit Corp., 475 U.S. 809, 811 (1986) (holding that Rule 52(a) requires that the district court's subsidiary factual determinations should be reviewed for clear error); cf. Graver Tank & Mfg. Co. v. Linde Air Prods. Co., 336 U.S. 271, 275 (1949) (holding that validity, while ultimately a question of law, is founded on factual determinations that are entitled to deference). "Under [section] 103, the scope and content of the prior art are to be determined; differences between the prior art and the claims at issue are to be ascertained; and the level of ordinary skill in the pertinent art resolved." Graham, 383 U.S. at 17.

To a significant degree, each of these factual inquiries is also necessary to claim construction. Before beginning claim construction, "the scope and content of the prior art [should] be determined," id., to establish context. The "differences between the prior art and the claims at issue [should] be ascertained," id., to better define what the inventor holds out as the invention. And, the foundation for both the obviousness and claim construction determinations is "the level of ordinary skill in the pertinent art." Id.; see Multiform, 133 F.3d at 1477. These underlying factual considerations receive the level of deference due under Rule 52(a) when considering obviousness, but they are scrutinized de novo in the claim construction context. As directed by the Supreme Court, however, it is especially important in the patent field, "where so much depends upon familiarity with specific scientific problems and principles not usually contained in the general storehouse of knowledge and experience," to give deference to the district

court's findings of fact. Graver Tank & Mfg. Co. v. Linde Air Prods. Co., 339 U.S. 605, 609-10 (1950).

While the court flails about in an attempt to solve the claim construction “conundrum,” the solution to our plight is straightforward. We simply must follow the example of every other appellate court, which, regarding the vast majority of factual questions, reviews the trial court for clear error.⁶ This equilibrium did not come about as the result of chance or permissive appellate personalities, but because two centuries of experience has shown that the trial court’s factfinding ability is “unchallenged.” Salve Regina Coll. v. Russell, 499 U.S. 225, 233 (1991); Inwood, 456 U.S. at 856 (“Determining the weight and credibility of the evidence is the special province of the trier of fact.”). Time has similarly revealed that it is more economical for the district court to find facts. Pierce, 487 U.S. at 560 (“Moreover, even where the district judge’s full knowledge of the factual setting can be acquired by the appellate court, that acquisition will often come at unusual expense, requiring the court to undertake the unaccustomed task of reviewing the entire record . . .”).

Therefore, not only is it more efficient for the trial court to construct the record, the trial court is better, that is, more accurate, by way of both position and practice, at finding facts than appellate judges. Anderson, 470 U.S. at 574 (“The rationale for deference to the original finder of fact is not limited to the superiority of the trial judge’s position to make determinations of credibility. The trial judge’s major role is the determination of fact, and with experience on fulfilling that role comes expertise.”); Zenith Radio Corp. v. Hazeltine Research, Inc., 395 U.S. 100, 123 (1969). Our rejection

⁶ While jurisprudentially sound, the bar also supports this proposition, as evident by the many amici curiae briefs urging adherence to Rule 52(a).

of this fundamental premise has resulted, not surprisingly, in several serious problems, including increased litigation costs, needless consumption of judicial resources, and uncertainty, as well as diminished respect for the court and less “decisional accuracy.” Salve, 499 U.S. at 233. We should abandon this unsound course.⁷

If we persist in deciding the subsidiary factual components of claim construction without deference, there is no reason why litigants should be required to parade their evidence before the district courts or for district courts to waste time and resources evaluating such evidence. It is excessive to require parties, who “have already been forced to concentrate their energies and resources on persuading the trial judge that their account of the facts is the correct one,” to “persuade three more judges at the appellate level.” Anderson, 470 U.S. at 575. If the proceedings before the district court are merely a “tryout on the road,” id. (quoting Wainwright v. Sykes, 433 U.S. 72, 90 (1977)), as they are under our current regimen, it is wasteful to require such proceedings at all. Instead, all patent cases could be filed in this court; we would determine whether claim construction is necessary, and, if so, the meaning of the claims. Those few cases in which claim construction is not dispositive can be remanded to the district court for trial. In this way, we would at least eliminate the time and expense of the charade currently played out before the district court.

Eloquent words can mask much mischief. The court’s opinion today is akin to rearranging the deck chairs on the Titanic—the orchestra is playing as if nothing is amiss, but the ship is still heading for Davey Jones’ locker.

⁷ There are some scenarios where it is difficult to weed facts from law, see Pullman-Standard, 456 U.S. at 288, but claim construction is not one of them.